



Share-based payment

Handbook

US GAAP

July 2024

frv.kpmg.us



Contents

| | |
|---|-----|
| Preface | 1 |
| Executive Summary | 4 |
| 1. Scope | 11 |
| 2. Measurement of Awards | 67 |
| 3. Classification of Awards as Either Liabilities or Equity | 160 |
| 4. Recognition of Compensation Costs | 246 |
| 5. Modification of Awards | 369 |
| 6. Income Tax Issues Associated with Share-Based Payment Arrangements | 451 |
| 7. Disclosures and Earnings per Share | 452 |
| 8. Transition and Effective Dates | 468 |
| 9. Business Combinations | 470 |
| 10. Equity-Based Transactions with Nonemployees | 471 |
| 11. Employee Stock Purchase Plans | 472 |
| KPMG Financial Reporting View | 490 |
| Acknowledgments | 492 |

Preface

We are pleased to provide you with our July 2024 edition of *Share-Based Payment*. This book is designed to assist companies and others in understanding the application of FASB ASC Topic 718, *Compensation—Stock Compensation*.

Excerpts of ASC Topic 718, *Compensation—Stock Compensation*, and ASC Subtopic 505-50, *Equity – Equity-Based Payments to Non-Employees*, copyright by the Financial Accounting Foundation, 401 Merritt 7, P.O. Box 5116, Norwalk, Connecticut 06856-5116, are included in this work by permission. In addition to the excerpts, this book provides interpretative guidance, illustrative examples, and questions and answers. This publication represents our current interpretation as of the date of this publication. Our interpretation may be affected by future guidance issued by the FASB or its staff, or others involved in the standard-setting process.

This edition has been updated to include our latest guidance on common practice issues. In addition, as applicable, it has been updated for recently issued ASUs that affect ASC Topic 718. This edition assumes an entity has adopted ASU 2020-06, *Debt – Debt with Conversion and Other Options (Subtopic 470-20) and Derivatives and Hedging-Contracts in an Entity’s Own Equity (Subtopic 815-40): Accounting for Convertible Instruments and Contracts in an Entity’s Own Equity*.

In March 2024, the FASB issued ASU 2024-01, *Compensation—Stock Compensation (Topic 718): Scope Application of Profits Interest and Similar Awards*, which provides an illustrative example including four fact patterns to demonstrate how an entity would apply the scope guidance in ASC paragraph 718-10-15-3 to determine whether profits interest awards should be accounted for in accordance with ASC Topic 718. This publication has been updated for ASU 2024-01, while also retaining the existing guidance that applies prior to adopting the ASU. Transition guidance is covered in Section 8, *Transition and Effective Dates*.

On July 1, 2009, the FASB issued the *FASB Accounting Standards Codification*[®] (ASC), which codified its existing accounting standards and became the single source of authoritative, nongovernmental U.S. GAAP, except for rules and interpretive releases of the SEC. The FASB issues Accounting Standards Updates (ASUs) that provide amendments and updates to the ASC as well as the basis for conclusions regarding the change in the Codification.

The Codification project’s intention was to retain existing U.S. GAAP. The Codification includes previous level A-D GAAP and excludes nonessential material such as much of the information contained in the Basis for Conclusions.

Accordingly, this book includes references to pre-Codification standards (e.g., Statement 123). As the FASB did not codify most of the Basis for Conclusions, which is cited in this book, references to those paragraphs do not contain an ASC reference.

In July 2024, we made the following significant updates or additions to the guidance to this handbook.

| <i>Topic</i> | <i>Reference</i> |
|---|--|
| Liabilities that Require Settlement in Shares | Q&A 1.3A |
| Secondary Transactions | 1.026b – 1.026g, Example 1.1d (edited from former Example 5.20a) |
| Profits Interests and Similar Awards (After Adoption of ASU 2024-01) | 1.054 – 1.065 Q&A 1.27, 1.28, 1.29 8.000 – 8.002 |
| Awards of Profits Interests to Employees (Before Adoption of ASU 2024-01) – content moved from Section 4 | 1.066 – 1.069 Q&A 1.30, 1.31, 1.32 4.132 – 4.135 deleted Example 4.44 deleted |
| Classifying Share-Based Payment Arrangements once Outside the Scope of US GAAP | 3.083b |
| Historical Experience versus Future Expectations | 2.024 |
| Share Price Input in Option-Pricing Model | 2.031 |
| Calculating Volatility | Q&A 2.5 |
| Valuation Impact of Secondary Market Transactions | Q&A 2.14 |
| Contingent Call Arrangements | 3.040a – 3.040c |
| Employee Share Awards to Be Paid in Shares Based on Earnings That Exceed a Specified Threshold | Example 3.13a |
| Discretionary Clawback Provisions (Including Effect of Dodd-Frank Wall Street Reform and Consumer Protection Act) | 4.045 – 4.047 |
| Graded-Vesting Employee Awards | 4.080 – 4.081 Q&A 4.15aa |
| Attribution Period for Employee Awards with Performance Conditions | 4.096 |
| Distinguishing Between a Settlement and Modification that Changes the Classification from Equity to a Liability | 5.026a |

| <i>Topic</i> | <i>Reference</i> |
|---|--|
| Settlement of Vested Shares in a Secondary Offering | Example 5.020a – moved to Example 1.1d |
| Excise Tax on Repurchases if the Price is in Excess of Fair Value | 5.031, Q&A 5.7bb |
| Modifications to Accelerate Vesting | 5.036 – 5.036a |
| ASUs 2018-07, 2019-08, 2021-07 – Transition Guidance | 8.010 – 8.018 deleted Q&As 8.1, 8.2, 8.3 deleted |

KPMG LLP

July 2024

Executive Summary

FASB ASC Topic 718, *Compensation-Stock Compensation*, requires entities to recognize as compensation cost the fair value of share options and other equity-based compensation issued to grantees. While ASC Topic 718 requires the use of an option pricing model to value grantee share options, it does not express a preference for a specific type of valuation model (i.e., Black-Scholes-Merton, lattice). ASC Topic 718 requires the use of a grant-date fair value model for equity-classified grants to grantees. For liability-classified awards, the awards are remeasured to fair value until settlement.

SCOPE

ASC Topic 718 sets accounting requirements for share-based compensation, including employee share purchase plans (ESPPs) and employee stock ownership plan transactions (ESOPs).

ESPPS USUALLY COMPENSATORY

ASC Topic 718 establishes criteria ESPPs must meet to be deemed noncompensatory. Consequently, most ESPPs are compensatory either because the plan contains a purchase price discount larger than permitted by ASC Topic 718 or because the plan contains a *look-back* feature.

CLASSIFYING AWARDS AS LIABILITIES OR EQUITY

AWARDS WITHIN THE SCOPE OF ASC TOPIC 718

The classification of an award as equity or liability is an important aspect of the accounting for share-based payment arrangements because the type of classification affects the measurement of compensation cost. Liability-classified awards are remeasured to fair value at each balance sheet date until the award is settled, or the award becomes equity-classified. Equity-classified awards are measured at grant-date fair value and are not subsequently remeasured.

Many awards with cash-based settlement or repurchase features, such as share appreciation rights with a cash-settlement feature, are liability-classified awards under ASC Topic 718. So too are awards for a fixed dollar amount settleable in the entity's stock. Additionally, ASC Topic 718 directs entities to consider their past settlement practice in classifying awards. For example, if an award's terms call for it to be equity-settled but the entity has a history of net-cash settling the award when an employee grantee makes such a request, the award would be liability-classified.

ASC Topic 718 permits equity classification for awards with a net-settlement feature to meet the grantor's statutory withholding requirements. However, if the amount that is withheld, or may be withheld at the grantee's discretion, is in excess of the grantee's

maximum individual statutory tax rate in the applicable jurisdictions, the entire award would be liability-classified. ASC Topic 718 provides conditions to be met for the award to be equity-classified when that award permits a cashless exercise using an unrelated broker. If the grantor uses a related-party broker, ASC Topic 718 imposes an additional condition that the broker must sell the shares in the open market within the normal settlement period for the award to be equity-classified. In addition, a put feature that gives grantees the right to require the entity to repurchase the shares at fair value permits the award to be equity-classified if the grantee bears the risks and rewards normally associated with ownership for a reasonable period of time, which is deemed to be six months or longer.

If an award vests or becomes exercisable based on the achievement of a condition other than a service, performance, or market condition, the award is liability-classified. Service, performance, and market conditions are explained below under *Recognizing Compensation*.

AWARDS OUTSIDE THE SCOPE OF ASC TOPIC 718

Under ASC paragraphs 718-10-35-9 through 35-12, ASC Topic 718 governs the classification of share-based payment arrangements after vesting as long as the awards were received for goods or services. However, if the awards are modified after vesting, and the grantee is no longer providing goods or services, is no longer a customer, or is no longer an employee, the award is classified as liability or equity using other GAAP. (In practice, alternatively, other GAAP may be applied to employee awards modified post-employment but prior to vesting.) Standards that may apply once an award is outside the scope of ASC Topic 718 include ASC Topic 815, *Derivatives and Hedging*, and ASC Subtopic 480-10, *Distinguishing Liabilities from Equity – Overall*. Once an instrument becomes subject to other GAAP, its classification may change from equity to liability or, potentially, vice-versa.

DETERMINING GRANT-DATE FAIR VALUE

The measurement objective is to estimate, as of the grant date, the fair value of an award that a grantee earns by having delivered the good or rendered service, or purchased goods or services as a customer, and satisfied other required conditions for the award to vest. The estimate of fair value would reflect transferability and other restrictions *only* if they are in effect after the award vests. For example, a restriction that includes a two-year prohibition on the sale of stock received from exercising share options would be incorporated into the estimate of grant-date fair value. Service and performance conditions do not directly affect an award's fair value. Both conditions are reflected by recognizing compensation cost only for awards that vest. Conversely, market conditions are incorporated into the determination of an award's grant-date fair value.

VALUATION MODELS

In the absence of an observable market price for an award, as is the case for most share options, entities are required to use a valuation method that market participants would use

to value the award. ASC Topic 718 expresses no preference for either a lattice model (e.g., a binomial model) or a closed-form model (e.g., a Black-Scholes-Merton model).

The Black-Scholes-Merton model often can provide a reasonable estimate of the fair value of share options. However, for some awards, particularly those with market conditions, entities may need to use a lattice model or another valuation approach (e.g., Monte Carlo simulation) to value the award. Both the Black-Scholes-Merton model and a lattice model incorporate, at a minimum, six inputs in valuing share options: (1) the stock price at grant date; (2) the exercise price of the share option; (3) the expected term of the share option; (4) the expected volatility of the stock during the expected term of the share option; (5) the dividend rate during the expected term of the share option; and (6) the risk-free rate during the expected term of the share option.

VALUATION GUIDANCE

ASC paragraph 718-10-S99-1 provides guidance on valuation techniques, in particular, two key inputs to the valuation of share options: expected volatility and expected term. Note that for nonemployee awards, the contractual term can be used instead of the expected term, and this can be decided on an award-by-award basis.

In addition, ASC paragraph 718-10-S99-1 explicitly acknowledges that the fair value of a share option at the grant date is unlikely to correspond to the amount that is ultimately realized by the option holder upon exercise. Differences between the actual outcomes and the original estimates of fair value, either with respect to the values reported or the assumptions used in developing the fair-value estimates, do not indicate that the original estimate was incorrect or inappropriate when the valuation was performed. In addition, ASC paragraph 718-10-S99-1 allows the entity to use a simplified method when estimating the expected term of *plain vanilla* share options.

ASC paragraph 718-10-S99-1 provides additional guidance on when the SEC staff believes it may be appropriate to use the simplified method to estimate the expected term of share option grants. The simplified method also may be applied to nonemployee awards, and the same additional guidance on when its use may be appropriate also applies to the nonemployee awards.

Staff Accounting Bulletin (SAB) 120 provides the SEC staff's view that entities should carefully consider whether an adjustment to the observable market price is required; for example, when share-based payment arrangements are entered into in contemplation of, or shortly before, a planned release of material nonpublic information, and such information is expected to result in a material increase in share price ('spring-loaded award').

EQUITY-CLASSIFIED AWARDS

An equity-classified award with an observable market price (e.g., a grant of nonvested shares) is valued at that price. Otherwise, the award is valued using a valuation model. Because an equity-classified award's valuation does not reflect restrictions that are in effect during the vesting period, a nonvested stock grant (commonly referred to as a

restricted stock grant) is valued at the market price of the shares on the date of grant. Equity-classified awards are not remeasured after the grant date.

LIABILITY-CLASSIFIED AWARDS

Public entities' liability-classified awards are remeasured to fair value each reporting period. Prior to vesting, cumulative compensation cost equals the proportionate amount of the award earned to date. For example, if a liability-classified award has a current fair value of \$50,000 and the employee has rendered 60% of the requisite service, the cumulative compensation cost recognized to that point would be \$30,000. Subsequent to vesting, the entire change in fair value is recorded in earnings.

NONPUBLIC ENTITY MEASUREMENTS

ASC Topic 718 permits nonpublic entities to substitute the historical volatility of an appropriate industry sector share-price index for the expected volatility of their share prices in the unusual situations where the entity is unable to estimate the historical volatility of its stock. The awards are then said to be valued at *calculated* value rather than at fair value. Valuations approaches which omit volatility are not permissible.

Nonpublic entities also are allowed to make an accounting policy election to apply a practical expedient for estimating the expected term of awards with service or performance conditions. This practical expedient accounting policy election would need to be made entity wide, and the expected term would be determined depending on the awards' vesting conditions.

Another accounting policy election available to nonpublic entities is to measure their *liability-classified* awards using either fair value or intrinsic value. In either case, the amount is remeasured at each financial statement date until the award is settled. Because the fair-value method is preferable, nonpublic entities can only make an intrinsic value election initially on the establishment of the awards.

Nonpublic entities may apply a practical expedient to determine the share price for equity-classified awards (e.g., restricted shares or the option-based award share price input to an option pricing model), by using a 'reasonable application of a reasonable valuation method.' A valuation method is considered reasonable if it considers all available information material to the value of the private entity; a valuation performed under IRC Section 409A would be acceptable. The practical expedient is available for both employee and nonemployee awards, must be elected on a measurement date-by-measurement date basis, and is applied to all equity-classified share-based payment awards with the same underlying share and measurement date.

RECOGNIZING COMPENSATION

The grant-date fair value of an equity-classified award is recognized as compensation cost over the employee's requisite service period or nonemployee's vesting period. The

employee's requisite service period or nonemployee's vesting period may be stated, either explicitly or implicitly, or it may be derived from the terms of the award.

Vesting can be based on a service condition, a performance condition, or a combination of both. A service condition is a requirement to achieve a specified duration of employment (e.g., an award vests after two years of service) or a nonemployee delivering goods or rendering services to the grantor over a vesting period. When the award has a service condition, there is an explicit service or vesting period (e.g., two years). A performance condition is a requirement to achieve an entity-specific operating or financial goal (e.g., an award vests after three years of service if the entity's average EPS for the next three years is \$4.00) or by reference to the grantee's performance related to the grantor's own operations (or activities). The service period of a performance condition may be either explicit (e.g., three years) or implicit. An example of a performance condition that creates an implicit service or vesting period is an award that vests when the entity's market share exceeds 30%. In such cases, the entity must estimate when it expects to achieve the target.

A market condition affects the exercisability of an award, not its vesting. A market condition is an exercisability requirement based on achieving a specified measure of the entity's share price (e.g., an award becomes exercisable if, during the next two years, the closing price of the entity's shares is above \$80 per share for 30 consecutive trading days). If an award's exercisability depends entirely on achieving a market condition, the employee's requisite service period or nonemployee's vesting period is derived from the valuation model.

An employee award containing more than one condition may have more than one explicit, implicit, or derived service or vesting period. In these situations, the entity determines from the service periods the employee's requisite service period or nonemployee's vesting period to recognize compensation cost. If an award contains two or more service periods, the employee's requisite service period or nonemployee's vesting period depends on whether the conditions are in an *or* or an *and* relationship. The employee's requisite service period or nonemployee's vesting period is the shortest of the periods that are in an *or* relationship or the longest of the periods in an *and* relationship.

For example, for an award that vests after four years of service (explicit) *or* when the entity's EPS exceeds \$3.00 for a quarter (implicit), the requisite service period would be the *shorter* of the service periods. Conversely, if the award vests on the completion of four years of service (explicit) *and* the entity's stock price exceeding \$50 per share for 10 consecutive trading days (derived), the requisite service period would be the *longer* of the service periods.

In addition, for both employee and nonemployee awards, even if only one of two or more conditions must be satisfied and a market condition is present in the terms of the award, compensation cost is recognized if the good is delivered or the service is rendered, regardless of whether the market, performance, or service condition is satisfied.

Compensation cost is recognized based on the number of awards that eventually vest. The amount recognized each period until the vesting date will depend on an entity-wide accounting policy election on forfeitures. An entity may elect to treat forfeitures (and therefore its accounting policy on compensation cost recognition) based on either:

- An estimate of the effect of the awards that are not expected to vest (forfeitures) in its initial accrual of compensation cost each year; or
- Recognize forfeitures in compensation cost when they occur.

If an entity elects to estimate its forfeitures, the estimate is adjusted up or down each period to reflect the current estimate of forfeitures, and, finally, the actual number of awards that vest.

If the employee works for the requisite service period, recognized compensation cost is not reversed even if the award expires unexercised. Therefore, if the employee worked for the requisite service period, the employee's inability to exercise an award because a market condition is not achieved does not cause recognized compensation cost to be reversed. Further, a recognized asset or expense will not be reversed if a stock option that the nonemployee has the right to exercise expires unexercised.

Compensation cost for awards that vest when a performance condition is achieved is recognized over the employee's requisite service period or nonemployee's vesting period if the condition is probable of achievement. If a performance condition is initially considered not probable of achievement but later is considered probable, the entity recognizes the cumulative amount of compensation earned to that point. Conversely, a change in the estimated employee's requisite service period or nonemployee's vesting period that does not change the total amount of compensation cost is recognized prospectively.

EMPLOYEE AWARDS WITH GRADED VESTING

Entities that grant employee awards with graded vesting based only on a service condition, such as an award that vests 25% at the end of each year over four years, make a policy election, choosing between two approaches for attribution for awards. The first approach is to treat each vesting tranche as a separate award with compensation cost for each award recognized over its vesting period. This approach results in a greater amount of compensation cost recognized in the earlier periods of the grant with a declining amount recognized in later periods. The second approach is to treat the award as a single award for recognition purposes (although the entity may value each tranche separately) and recognize compensation cost on a straight-line basis over the requisite service period of the entire award.

MODIFIED AWARDS

An award may be modified by changing its exercise price, extending its life, or revising its vesting conditions. The accounting for an award modification depends on the

likelihood, at the date of the modification, that the original award would have vested. If, at that time, it is *not* probable that the original award would have vested, the cumulative compensation cost to be recognized would be the value of the modified award. This situation commonly arises when an employee is to be terminated before the award's vesting and the employer changes the award so that it vests at the employee's termination. In that case, the recognized compensation cost would equal the fair value of the modified award at the modification date. However, if, at the modification date, it is probable that the original award would have vested, the cumulative compensation cost to be recognized would equal the grant-date fair value of the original award plus the incremental value of the modified award.

An entity would apply modification accounting to a modification, unless all of the following are the same immediately before and after the modification: fair value; vesting conditions of the award; and the classification as either a liability or equity instrument. See Section 5, *Modification of Awards*.

INCOME TAX CONSIDERATIONS

Under ASC Topic 740, *Income Taxes*, the cumulative compensation cost recognized for an award that would result in a future tax deduction is a deductible temporary difference. Therefore, the deductible temporary difference is based on the compensation cost recognized for financial reporting purposes. Under U.S. tax law, deductions are based on the intrinsic value of an award at a specific date, generally at exercise for share options and at vesting for nonvested share grants. As a result, differences are likely between the compensation cost recognized for financial reporting purposes and the deduction for tax purposes. All excess tax benefits (i.e., intrinsic value at exercise exceeds grant-date fair value) and tax deficiencies (i.e., when the intrinsic value at exercise is less than the grant-date fair value) are recognized as income tax expense or benefit in the income statement.

Section 1 - Scope

Detailed Contents

Introduction

Q&A 1.1: Shares Issued to a Service Provider

Q&A 1.2: Stock Appreciation Rights

Q&A 1.3: Award Indirectly Tied to Stock Performance Rights

Q&A 1.3a: Liabilities that May Require Settlement in Shares

Employee Versus Nonemployee Awards

Definition of an Employee

Q&A 1.4: Criteria for Determining Employee Status

Directors

Example 1.1: Share Options Issued to a Nonemployee Director Elected by the Minority Shareholder

Q&A 1.5: Share Options Granted to an Advisory Board Member

Q&A 1.6: Share Options Issued to Directors

Q&A 1.7: Share Options Granted to an Advisory Board Member

Employees of Pass-Through Entities

Employee and Nonemployee Awards of the Consolidated Group in the Consolidated Financial Statements

Employee and Nonemployee Awards of an Equity Method Investee in the Investor's Financial Statements

Q&A 1.8: Award in Investor Shares Granted to Employees of Equity Method Investee

Q&A 1.9: Awards Granted to Employees of a Nonconsolidated Majority-Owned Entity

Q&A 1.10: Award Granted by Investor to Its Employees Based on Shares of Equity Method Investee

Employee and Nonemployee Awards of a Subsidiary in the Separate Financial Statements of the Subsidiary

Q&A 1.11: Awards Granted by a Member of a Consolidated Group to Another Member of the Consolidated Group (Sibling Award)

Q&A 1.12: Awards in Parent Shares Granted to Employees of a Consolidated Subsidiary (Downstream Award)

Q&A 1.12a: Awards of Nonvested Puttable Shares in Parent Granted to Employees of a Consolidated Subsidiary (Downstream Award)

Q&A 1.13: Awards in Subsidiary Shares Granted to Parent Employees (Upstream Award)

Q&A 1.14: Subsidiary Shares Issued to Parent Employees and Nonemployees (Upstream Award)

Q&A 1.15: Share Option Awards Granted to a Director of a Subsidiary Who Is Also an Employee of the Parent

Q&A 1.16: Effect of Shareholder Loans on Noncontrolling Interest

Q&A 1.17: Share Option Awards Granted to Employees of the Parent to Purchase Shares of a Subsidiary's Stock

Employee Leasing Arrangements

Changes in Grantee Status

Example 1.1a: Change in Grantee Status: Part I

Example 1.1b: Change in Grantee Status: Part II

Example 1.1c: Change in Grantee Status: Part III

Awards in Shares of a Related Entity

Tracking Stock Awards

Q&A 1.18: Share Options to Purchase Tracking Stock

Related Parties and Economic Interest Holders

Q&A 1.19: Transfer by an Economic Interest Holder

Q&A 1.20: Share Transfer by an Economic Interest Holder for a Purpose Other Than Compensation

Q&A 1.21: Share Transfer by an Economic Interest Holder for Less Than Fair Value – Part I

Q&A 1.21a: Share Transfer by an Economic Interest Holder for Less Than Fair Value – Part II

Secondary Transactions

Q&A 1.21b: Employee Sale of Vested Shares in a Secondary Offering

Example 1.1d: Settlement of Vested Shares in a Secondary Offering

Employee Share Purchase Plans

Q&A 1.22: Employee Share Purchase Plan to All Employees and Shareholders

Q&A 1.23: Employee Share Purchase Plan with Differing Terms for Employees and Nonemployee Shareholders

Q&A 1.24: Compensatory Employee Share Purchase Plan Based on a Formula

Q&A 1.25: Noncompensatory Employee Share Purchase Plan Based on a Formula

Awards in Shares of a Non-Related Company

Q&A 1.26: Share Options of an Unrelated Company

Example 1.2: Recognition and Measurement of Share Options Granted on Stock of Unrelated Company

Escrowed Share Arrangements in an IPO

Deferred Compensation Arrangements

Profits Interests and Similar Awards (After adoption of ASU 2024-01)

Excerpt from ASC 718-10-55-138 through 55-148

Q&A 1.27: Award of Profits Interests – Not in the Scope of ASC 718

Q&A 1.28: Award of Profits Interests – In the Scope of ASC Topic 718 (1)

Q&A 1.29: Award of Profits Interests – In the Scope of ASC Topic 718 (2)

Awards of Profits Interests to Employees (Before adoption of ASU 2024-01)

Q&A 1.30: Award of Profits Interests – Part I

Q&A 1.31: Award of Profits Interests – Part II

Q&A 1.32: Award of Profits Interests – Part III

INTRODUCTION

1.000 ASC Topic 718 applies to all share-based payment transactions in which an entity acquires goods or services to be used or consumed in its operations, or provides consideration payable to a customer, by: ASC paragraph 718-10-15-3

- (1) Issuing its shares, share options, or other equity instruments (See Q&A 1.1)
- (2) Incurring liabilities that meet either of the following conditions:
 - a. the amounts are based, at least in part, on the price of the entity's shares or other equity instruments (See Q&A 1.2 and 1.3), or
 - b. require or may require settlement by issuing the entity's shares or other equity instruments (See Q&A 1.3a).

1.001 ASC Topic 718 applies both to share-based payment transactions with employees and nonemployees (which include share-based payment transactions with customers) in exchange for their services, including employee share purchase plans (ESPPs) deemed compensatory in nature (See Paragraphs 1.027 through 1.038 for ESPPs). However, ASC Topic 718 does not apply to transactions involving equity instruments granted to a lender or investor that provides financing to the issuer. ASC paragraph 718-10-15-3, 718-10-15-5

1.002 Employee Stock Ownership Plans (ESOPs) are accounted for under ASC Subtopic 718-40, Compensation—Stock Compensation – Employee Stock Ownership Plans. See Chapter 12 of KPMG Handbook, Employee benefits for further discussion on the accounting for ESOPs.

1.003 Not used.

Q&A 1.1: Shares Issued to a Service Provider

Q. ABC Corp. issues its shares to a law firm as payment for legal services. Is this transaction within the scope of ASC Topic 718?

A. Yes. Because ABC issued its shares as payment for services received, the transaction is within the scope of ASC Topic 718.

Q&A 1.2: Stock Appreciation Rights

Q. ABC Corp. issues a stock appreciation right (SAR). The SAR requires the entity to pay the grantee an amount equal to the appreciation in the value of 1,000 shares of its stock over a two-year period. Is this transaction within the scope of ASC Topic 718?

A. Yes. ABC has incurred a liability for which payment is based on the price of its shares, so the transaction is within the scope of ASC Topic 718.

Q&A 1.3: Award Indirectly Tied to Stock Performance Rights

Q. ABC Corp. has an award plan that is paid in cash, based on a formula that is not directly tied to the equity of ABC, but for which an input into the formula (a multiplier) is based on the performance of ABC's stock price. ABC issues 100 performance units to a grantee. Each performance unit has a value of \$1. ABC has identified 10 peer companies within its industry. At the end of a three-year period, ABC determines its total shareholder return (TSR) against the TSR of the peer group. Depending on where ABC's TSR falls within the peer group, the 100 performance units will vest in a percentage ranging from 0% to 200%. At the end of the three-year TSR measurement period, a cash payment is made to the grantee equal to the number of performance units that vest multiplied by \$1. Are the awards under this plan within the scope of ASC Topic 718?

A. Yes. The ultimate cash payment is equal to the number of performance units that vest multiplied by \$1. The performance unit is not linked to any equity instrument and is itself not an equity instrument. However, the number of performance units that ultimately vest depends on the TSR of ABC compared to the TSR of the peer group. Accordingly, the ultimate cash payment is based, *at least in part*, on ABC's stock price. Therefore, this arrangement is within the scope of ASC Topic 718

Q&A 1.3a: Liabilities that May Require Settlement in Shares

Q. ABC Corp. grants certain executives a bonus that entitles the executives to \$500,000 settled in a variable number of ABC Corp.'s shares determined by ABC Corp.'s stock price at the settlement date. Are the awards under this plan within the scope of ASC Topic 718?

A. Yes. ABC Corp. incurred a liability which is settled by issuing its shares. Therefore, this arrangement is within the scope of ASC Topic 718.

EMPLOYEE VERSUS NONEMPLOYEE AWARDS

1.004 ASC Topic 718 includes share-based payment awards issued to both employees and nonemployees for goods and services. In addition, awards issued as consideration payable to a customer that are not consideration for a distinct good or service are measured and classified (equity or liability) in accordance with ASC Topic 718 but are recognized as a reduction in the transaction price in accordance with ASC Topic 606. Consequently, the accounting for share-based payment awards to nonemployees (including customers) and employees is substantially aligned with some differences, including specific guidance on inputs to an option pricing model and differences in cost attribution for nonemployee awards, and differences in the income statement recognition for awards issued to customers. Therefore, despite the similarities, an entity needs to continue to determine whether awards are issued to employees or nonemployees. See KPMG Handbook,

Revenue recognition, Chapter 5, Question 5.7.20, for further discussion on accounting for equity-based instruments granted to customers.

Definition of an Employee

1.005 ASC Section 718-10-20 defines an employee as:

An individual over whom the grantor of a share-based compensation award exercises or has the right to exercise sufficient control to establish an employer-employee relationship based on common law as illustrated in case law and currently under U.S. Internal Revenue Service Revenue Ruling 87-41. A reporting entity based in a foreign jurisdiction would determine whether an employee-employer relationship exists based on the pertinent laws of that jurisdiction. Accordingly, a grantee meets the definition of an employee if the grantor consistently represents that individual to be an employee under common law. The definition of an employee for payroll tax purposes under the U.S. Internal Revenue Code includes common law employees. Accordingly, a grantor that classifies a grantee potentially subject to U.S. payroll taxes as an employee also must represent that individual as an employee for payroll tax purposes (unless the grantee is a leased employee as described [in Paragraph 1.018]). A grantee does not meet the definition of an employee solely because the grantor represents that individual as an employee for some, but not all, purposes. For example, a requirement or decision to classify a grantee as an employee for U.S. payroll tax purposes does not, by itself, indicate that the grantee is an employee because the grantee also must be an employee of the grantor under common law. ASC Section 718-10-20

1.006 Based on the definition above, a grantee is an employee only if the grantor can establish that an employer-employee relationship exists under common law. In evaluating this relationship, the grantor should apply case law and Internal Revenue Service Revenue Ruling 87-41, “Employment Status Under Section 530(D) of the Revenue Act of 1978.” As the IRS definition of *employee* for payroll tax purposes includes common law employees, an individual who is an employee for financial reporting purposes, with the exception of certain independent directors (see Paragraph 1.009), employee owners of pass-through entities (see Paragraph 1.012), and certain employee leasing arrangements (see Paragraph 1.018), may also be treated as an employee for payroll tax purposes (i.e., the common law criteria should be interpreted consistently). However, because the U.S. Internal Revenue Code definition of an employee for payroll tax purposes includes certain service providers who are not common law employees, classifying a grantee as an employee for payroll tax purposes does not absolve the grantor from evaluating the relationship to ensure that the grantee is an employee under common law and, consequently, for financial reporting purposes.

1.007 Revenue Ruling 87-41 provides 20 factors to be considered in determining whether an individual is an employee under common law. These factors are designed only as guidelines, and the degree of importance of each factor varies depending on the occupation and the context in which the services are performed. The evaluation should

focus on whether the entity receiving the services exercises sufficient control over the services provided by the individual, as required.

- (1) **Instructions.** A worker who is required to comply with other persons' instructions about when, where, and how he or she is to work is ordinarily an employee. This control factor is present if the person for whom the services are performed has the right to require compliance with instructions.
- (2) **Training.** Training a worker by requiring an experienced employee to work with the worker, by corresponding with the worker, by requiring the worker to attend meetings, or by using other methods, indicates that the person for whom the services are performed wants the services performed in a particular method or manner.
- (3) **Integration.** Integration of the worker's services into the business operations generally shows that the worker is subject to direction and control. When the success or continuation of a business depends to an appreciable degree on the performance of certain services, the workers who perform those services must necessarily be subject to a certain amount of control by the owner of the business.
- (4) **Services Rendered Personally.** If the services must be rendered personally, presumably the person for whom the services are performed is interested in the methods used to accomplish the work as well as in the results.
- (5) **Hiring, Supervising, and Paying Assistants.** If the person for whom the services are performed hires, supervises, and pays assistants, that factor generally shows control over the workers on the job. However, if one worker hires, supervises, and pays the other assistants pursuant to a contract under which the worker agrees to provide materials and labor and under which the worker is responsible only for the attainment of a result, this factor indicates an independent contractor status.
- (6) **Continuing Relationship.** A continuing relationship between the worker and the person for whom the services are performed indicates that an employer-employee relationship exists. A continuing relationship may exist where work is performed at frequently recurring although irregular intervals.
- (7) **Set Hours of Work.** The establishment of set hours of work by the person for whom the services are performed is a factor indicating control.
- (8) **Full-Time Required.** If the worker must devote substantially full time to the business of the person for whom the services are performed, such person has control over the amount of time the worker spends working, and an implied restriction exists preventing the worker from doing other gainful work. An independent contractor, on the other hand, is free to work when and for whom he or she chooses.
- (9) **Doing Work on Employer's Premises.** If the work is performed on the premises of the person for whom the services are performed, that factor suggests control over the worker, especially if the work could be done elsewhere. Work done off the premises of the person receiving the services, such as at the office of the worker, indicates some freedom from control. However, this fact by itself does not mean

that the worker is not an employee. The importance of this factor depends on the nature of the service involved and the extent to which an employer generally would require that employees perform such services on the employer's premises. Control over the place of work is indicated when the person for whom the services are performed has the right to compel the worker to travel a designated route, to canvass a territory within a certain time, or to work at specific places as required.

- (10) **Order or Sequence Set.** If a worker must perform services in the order or sequence set by the person for whom the services are performed, that factor shows that the worker is not free to follow the worker's own pattern of work but must follow the established routines and schedules of the person for whom the services are performed. Often, because of the nature of an occupation, the person for whom the services are performed does not set the order of the services or sets the order infrequently. It is sufficient to show control, however, if such person retains the right to do so.
- (11) **Oral or Written Reports.** A requirement that the worker submit regular or written reports to the person for whom the services are performed indicates a degree of control.
- (12) **Payment by Hour, Week, or Month.** Payment by the hour, week, or month generally points to an employer-employee relationship, provided that this method of payment is not just a convenient way of paying a lump sum agreed upon as the cost of a job. Payment made by the job or on a straight commission generally indicates that the worker is an independent contractor.
- (13) **Payment of Business and/or Traveling Expenses.** If the person for whom the services are performed ordinarily pays the worker's business and/or traveling expenses, the worker is ordinarily an employee. An employer, to be able to control expenses, generally retains the right to regulate and direct the worker's business activities.
- (14) **Furnishing of Tools and Materials.** The fact that the person or persons for whom the services are performed furnish significant tools, materials, and other equipment tends to show the existence of an employer-employee relationship.
- (15) **Significant Investment.** If the worker invests in facilities that are used by the worker in performing services and are not typically maintained by employees (such as the maintenance of an office rented at fair value from an unrelated party), tends to indicate that the worker is an independent contractor. On the other hand, lack of investment in facilities indicates dependence on the person or persons for whom the services are performed for such facilities and, accordingly, the existence of an employer-employee relationship. Special scrutiny is required with respect to certain types of facilities, such as home offices.
- (16) **Realization of Profit or Loss.** A worker who can realize a profit or suffer a loss as a result of the worker's services (in addition to the profit or loss ordinarily realized by employees) is generally an independent contractor, but the worker who cannot do so is an employee. For example, if the worker is subject to a real risk of economic loss due to significant investments or a bona fide liability for expenses,

such as salary payments to unrelated employees, that factor indicates that the worker is an independent contractor. The risk that a worker will not receive payment for his or her services, however, is common to both independent contractors and employees and thus does not constitute a sufficient economic risk to support treatment as an independent contractor.

- (17) **Working for More Than One Firm at a Time.** If a worker performs more than de minimis services for a multiple of unrelated persons or firms at the same time, that factor generally indicates that the worker is an independent contractor. However, a worker who performs services for more than one person may be an employee of each of the persons, especially where such persons are part of the same service arrangement.
- (18) **Making Service Available to the General Public.** The fact that a worker makes his or her services available to the general public on a regular and consistent basis indicates an independent contractor relationship.
- (19) **Right to Discharge.** The right to discharge a worker is a factor indicating that the worker is an employee and the person possessing the right is an employer. An employer exercises control through the threat of dismissal, which causes the worker to obey the employer's instructions. An independent contractor, on the other hand, cannot be fired as long as the independent contractor produces a result that meets the contract specifications.
- (20) **Right to Terminate.** If the worker has the right to end his or her relationship with the person for whom the services are performed at any time he or she wishes without incurring liability, that factor indicates an employer-employee relationship.

Q&A 1.4: Criteria for Determining Employee Status

Q. What criteria should an entity consider when determining whether an employer-employee relationship exists under common law?

A. Whether an individual is considered an employee under common law depends on all the facts and circumstances and involves considerable judgment, especially because there are numerous court cases, revenue rulings, and private letter rulings that establish precedents in applying these rules. An entity can apply for a private letter ruling from the IRS that determines the employment status of an individual. Entities should consult their legal counsel in determining employment status under the common law rules.

1.008 A reporting entity based in a foreign jurisdiction would assess employee status based on the laws of that jurisdiction. ASC Section 718-10-20

Directors

1.009 Although a nonemployee member of an entity's board of directors does not meet the common law definition of an employee, certain directors are treated as employees in accounting for share-based compensation granted to a nonemployee director for services

as a director. To qualify for treatment as an employee, the nonemployee director either is elected by the entity's shareholders or is appointed to a board position that will be filled by shareholder election when the existing term expires. ASC paragraph 718-10-55-91

1.010 Awards granted to individuals for advisory or consulting services in a nonelected capacity or to nonemployee directors for services rendered outside their role as a director (e.g., legal advice, investment banking advice, or loan guarantees) are accounted for as awards to nonemployees. ASC Section 718-10-20

1.011 For groups of entities, the guidance with respect to nonemployee directors relates to their role as members of the parent entity board of directors, and to those directors on the boards of other group entities who were elected to that position by parties or investors not controlled by the group or a group entity. ASC paragraph 718-10-55-91

Example 1.1: Share Options Issued to a Nonemployee Director Elected by the Minority Shareholder

During 20X5, ABC Corp. issues 5,000 share options to Director X, a nonemployee director of subsidiary Y. Director X was elected by the minority shareholders of subsidiary Y (therefore, elected by shareholders not controlled by ABC) and the majority shareholders were precluded from voting for Director X.

In this example, ABC accounts for the share options as employee awards in its consolidated financial statements. If however, Director X was not elected by the minority shareholders of subsidiary Y (or if the majority shareholders were not precluded from voting for Director X), the share options for services as a director of subsidiary Y would be accounted for as awards to nonemployees in ABC's consolidated financial statements. In the subsidiary's financial statements however, if Director X was elected by subsidiary Y's shareholders (including the controlling shareholders), the share options to Director X for services as a director would be accounted for as employee awards. Also, see Q&A 1.15.

Q&A 1.5: Share Options Granted to an Advisory Board Member

Q. Company A forms a master limited partnership (MLP) and intends to provide share-compensation to certain directors of the MLP that will vest over a period of years. The general partnership owns 0.5% of the equity at risk of the MLP and controls the MLP. Company A, the general partner, determines the board of directors of the MLP. In addition, the limited partner (LP) members of the MLP lack substantive kick-out rights to remove Company A as general partner (GP) or in determining the board of directors. Company A also holds 90% of the LP interests. Will the directors of the MLP that are appointed by the GP be considered employees of the MLP under ASC Topic 718?

A. Yes, however different combinations of GP and LP interests held and governance provisions may yield different conclusions. The definition of *employee* for purposes of

ASC Topic 718 includes nonemployee directors acting in their role as members of an entity's board of directors if those directors were elected by the entity's shareholders or appointed to a board position that will be filled by a shareholder election when the existing term expires. The board of directors is not elected by the LP members (who have substantially all of the equity at risk in the entity) and the LP members lack substantive kick-out rights in electing the board of directors. Therefore, it is not clear that the spirit of the guidance for the *elected director exception* is met solely through Company A holding the controlling GP interest. However, in this instance, Company A also holds 90% of the LP members' interests of the limited partnership. Therefore, we believe it is reasonable to combine the 90% LP interest and the controlling GP interest to support a view that the directors are elected by the shareholders and eligible to be accounted for as employee awards under ASC Topic 718.

Q&A 1.6: Share Options Issued to Directors

Q. During 20X5, ABC Corp. issues 5,000 share options to Director X, a nonemployee director elected by the shareholders to ABC's board of directors. During 20X5, Director X, who is an attorney, served as the legal advisor to ABC's chemical business on a patent infringement case. How should ABC account for the 5,000 share options issued to Director X?

A. ABC will need to determine how many of the share options issued to Director X were for his services as a director and how many were for his legal services. Those share options attributable to his service as a director are accounted for as employee awards, while the remaining share options are accounted for as nonemployee awards. Factors that ABC should consider in determining the appropriate accounting for the 5,000 share options include:

- a. Formal company policies, if available, that establish the number of share options directors are entitled to receive for their services. Many companies establish either a fixed number of share options per year or a sliding scale based on number of meetings attended, committee service, and responsibility;
- b. The number, terms, and timing of share option awards received by other nonemployee directors with comparable director duties; and
- c. The amount of other compensation, if any, paid for the legal services and the value of those services, which could be based on the director's standard billing rate for legal services. ASC paragraph 718-10-55-91

Q&A 1.7: Share Options Granted to an Advisory Board Member

Q. ABC Corp. has an advisory board whose members have specific knowledge and expertise about the entity's industry. The advisory board provides guidance to management on matters including policy development, future technology, and product improvement. ABC generally appoints its advisory board members for annual terms, and

the advisory board meets two or three times per year. ABC grants share options to members of the advisory board to compensate them for their services. Are those grants accounted for using the guidance for employee awards?

A. No. In the circumstances described, the advisory board members do not qualify as employees under common law and they do not meet the nonemployee director exemption because the shareholders do not elect them. Accordingly, awards to the advisory board members are accounted for as nonemployee awards. ASC paragraph 718-10-55-90

Employees of Pass-Through Entities

1.012 Employee/owners of pass-through entities, such as limited liability companies or partnerships, are not employees for payroll purposes (i.e., they do not receive W-2s). It is not uncommon for these employee/owners to receive equity compensation for their services. If the employee/owners qualify as common law employees, they are employees for financial reporting purposes even though they do not receive W-2s.

Employee and Nonemployee Awards of the Consolidated Group in the Consolidated Financial Statements

1.013 An entity evaluates at the consolidated group level whether an award should be accounted for as an employee or nonemployee award in the consolidated financial statements. An employee of any member of the consolidated group is considered to be an employee in the financial statements of the consolidated group. Likewise, the shares of any member of the consolidated group are considered to be shares of the consolidated group in the financial statements of the consolidated group. Consequently, in the consolidated financial statements, grants or awards by a member of the consolidated group to an employee of another member of the group are accounted for as employee awards. Depending on the facts and circumstances, the accounting might be different in the separate financial statements of a member of the consolidated group.

Employee and Nonemployee Awards of an Equity Method Investee in the Investor's Financial Statements

1.014 Awards based on the shares of an investor granted to an employee or nonemployee of an unconsolidated investee or joint venture, in which the employee or nonemployee provides goods or services to the investee that are used or consumed in the investee's operations when no proportionate funding by the other investors occurs, and the investor does not receive any increase in the investor's relative ownership percentage of the investee are addressed in ASC paragraphs 323-10-25-3 through 25-6. Those provisions require that an investor expense the cost of share-based payments made to an employee or nonemployee of an equity method investee as incurred to the extent that the investor's claim on the investee's book value has not been increased. The expense recognized under ASC paragraph 323-10-25-4 should be measured at fair value using the measurement guidance contained in ASC Topic 718.

Q&A 1.8: Award in Investor Shares Granted to Employees of Equity Method Investee

Q. Investor holds an equity method investment in Investee. Investor grants share options in its common shares to employees of Investee. Is it appropriate for Investor to account for these awards as employee share options?

A. No. Employees of Investee are not employees of Investor because Investee is not consolidated in the financial statements of Investor. Therefore, the awards are not employee awards. Those awards should be accounted for as nonemployee awards under ASC paragraphs 323-10-25-3 through 25-6 and be measured initially at fair value in accordance with ASC Topic 718. Investee would recognize expense measured on the same basis as Investor, with a corresponding capital contribution from Investor. Note that the accounting treatment would be the same if the awards were provided to nonemployees of Investee, in that whether the awards are to employees or nonemployees of Investee, the awards would be accounted for by Investor as nonemployee awards under ASC Topic 718.

Q&A 1.9: Awards Granted to Employees of a Nonconsolidated Majority-Owned Entity

Q. Investor owns 60% of the voting common shares of Investee; however, due to certain participating rights as defined in ASC paragraphs 810-10-25-1 through 25-14 and 55-1, held by the minority shareholders, Investor does not consolidate Investee. Investor grants share options in Investor's common shares to employees of Investee. Is it appropriate for Investor to account for these awards as employee share options?

A. No. Investee is not part of Investor's consolidated group and, therefore, employees of Investee are not deemed to be employees of Investor. Investor should account for these awards as nonemployee awards under ASC paragraphs 323-10-25-3 through 25-6.

Q&A 1.10: Award Granted by Investor to Its Employees Based on Shares of Equity Method Investee

Q. Investor holds an equity method investment in Investee. Investor grants its employees share options written on its shares of Investee. The share options allow employees to purchase shares of Investee from Investor at a fixed price equal to the market value of Investee's shares at the date of grant. How should Investor account for the grant of share options?

A. Because Investor granted share options based on equity of an unconsolidated entity, the award should be accounted for as a written option. There is mixed practice in the

accounting for this type of award during the vesting period, as described in Paragraph 1.035.

Employee and Nonemployee Awards of a Subsidiary in the Separate Financial Statements of the Subsidiary

1.015 In the separate financial statements of a subsidiary, the entity evaluates at the subsidiary level whether the recipient of the award is an employee or nonemployee. Employee accounting applies to awards granted by the subsidiary in the subsidiary's shares only to its own employees. Therefore, employee accounting does not apply in the separate financial statements of a subsidiary for awards granted by the subsidiary to employees of another member of the consolidated group (sibling awards) because the recipient of the award is not an employee of the subsidiary. Also, employee accounting does not apply to awards granted by a subsidiary to employees of the parent (upstream awards) in the subsidiary's financial statements.

1.016 An exception to the concept in Paragraph 1.015 applies to awards based on shares of the parent company granted to the employees of a consolidated subsidiary (downstream awards). Employee accounting does apply to these grants (for both equity- and liability-classified awards at the parent company) in the subsidiary's separate financial statements.

Q&A 1.11: Awards Granted by a Member of a Consolidated Group to Another Member of the Consolidated Group (Sibling Award)

Q. Company X has two subsidiaries, A and B. Subsidiary A grants its employees share options on the shares of Subsidiary B to be settled with Subsidiary B shares that Company X already owns. Does this grant qualify for employee accounting in the consolidated financial statements? Does it qualify for employee accounting in Subsidiary A's standalone financial statements?

A. Because Subsidiaries A and B are both members of a consolidated group, the grants are considered employee awards in the consolidated financial statements of Company X. However, the awards are not considered employee awards in the separate financial statements of Subsidiary A because the share options are based on the shares of an entity that is not consolidated in its financial statements. In this case, the awards would be accounted for as nonemployee awards in the financial statements of Subsidiary A and treated as a written option by analogy to the guidance contained in ASC paragraph 815-10-45-10. Because Subsidiary B is not party to the arrangement, there would be no accounting consequence in Subsidiary B's separate financial statements.

Q&A 1.12: Awards in Parent Shares Granted to Employees of a Consolidated Subsidiary (Downstream Award)

Q. Parent grants share options in its shares to employees of Subsidiary. How should this award be accounted for in the consolidated financial statements and in the separate financial statements of Subsidiary?

A. In the consolidated financial statements, share-based payment awards granted in the shares of any consolidated group member should be accounted for as employee awards if the grantee meets the definition of an employee of any entity in the consolidated group. Accordingly, the award of Parent shares granted to Subsidiary employees is accounted for as employee awards in the consolidated financial statements. The award also would be accounted for as employee awards in Subsidiary's separate financial statements. Compensation cost related to the grant of these share options would be recorded at the subsidiary level and with a corresponding credit to equity, representing Parent's capital contribution, unless Subsidiary provides Parent consideration for the awards.

Q&A 1.12a: Awards of Nonvested Puttable Shares in Parent Granted to Employees of a Consolidated Subsidiary (Downstream Award)**Background**

Certain employees of a consolidated subsidiary (Subsidiary X) receive a grant of nonvested shares from Parent. Parent classifies these awards as liabilities in its consolidated financial statements, since the shares contain a feature that allows the employee, on vesting, to put the shares back to the Parent at any time at the then-fair market value of the shares. However, Subsidiary X has no obligation to settle these awards, either to the Parent or to the recipients.

Q. How should this award be classified in the separate financial statements of Subsidiary X?

A. The award should be accounted for as employee awards in Subsidiary X's separate financial statements. Compensation cost related to the grant of these shares would be recorded at Subsidiary X with a corresponding credit to equity, representing Parent's capital contribution. Subsidiary X would recognize the compensation cost for these awards at the same time and for the same amount as they are recognized by the Parent.

Since the awards are liability-classified at the Parent level, compensation costs and the corresponding equity amounts at Subsidiary X should be adjusted at each reporting period until the award is settled, which may result in negative compensation expense and a deemed capital distribution for a reporting period if there is a decline in the fair value of the award during that period.

Q&A 1.13: Awards in Subsidiary Shares Granted to Parent Employees (Upstream Award)

Q. Parent grants its employees share options to purchase common shares of Subsidiary held by Parent at a fixed price equal to the fair value of the shares of Subsidiary at the date of grant. The employees being granted awards do not provide services directly to or related to Subsidiary's operations. How should Parent account for the grant of share options and subsequent exercise in the consolidated financial statements and how should Subsidiary account for the share options in its separate financial statements?

Parent's Consolidated Financial Statements

A. In its consolidated financial statements, Parent should account for the share options as employee awards. Share-based payments granted based on the shares of any consolidated group member are accounted for as employee awards if the grantee meets the definition of an employee for any entity in the consolidated group under ASC Topic 718.

We believe that a parent entity may apply either of two methods to account for the noncontrolling interest associated with the grant of share options prior to exercise. Each of these methods would result in the same amount of compensation cost and noncontrolling interest on exercise or expiration of the awards. In addition, under both methods, no profit or loss from Subsidiary would be attributed to the noncontrolling interest during the time the share options are outstanding but unexercised because the share options would not represent a current residual equity interest in the entity.* However, there would be differences in the amounts of noncontrolling interest and additional paid-in capital during the intervening periods. The two acceptable methods are described below.

*This assumes the holder of the award does not participate in dividends. If so, there may be an allocation of earnings to the awards as part of applying the two-class method of earnings per share. See KPMG Handbook, Earnings Per Share, Chapter 5.

Method 1. Parent would recognize in the consolidated financial statements noncontrolling interest in an amount equal to the cumulative compensation cost recognized to date (at the vesting date this amount would equal the grant-date fair value of the share options).

On exercise of the share options, assuming Parent retains control of Subsidiary, Parent would adjust noncontrolling interest in Subsidiary measured at the proportionate interest in Subsidiary's equity as measured in Parent's consolidated financial statements. The difference between the cash received on exercise plus the amount included in equity from the recognition of the compensation cost (i.e., the grant-date fair value of the share-based payment) and the noncontrolling interest would be recognized as an increase or decrease to Parent's additional paid-in capital.

If the share options expire unexercised, then the amount recognized in noncontrolling interest would be reclassified from the noncontrolling interest to Parent's additional paid-in-capital (i.e., the controlling interest).

Method 2. Unlike Method 1, no amount would be recorded as noncontrolling interest prior to exercise of the share options. Instead, Parent would recognize in the consolidated financial statements additional paid-in capital in an amount equal to the cumulative compensation cost recognized to date (at the vesting date this amount would equal the grant-date fair value of the share options).

On exercise of the share options, assuming Parent retains control of Subsidiary, Parent would record noncontrolling interest in Subsidiary measured at the proportionate interest in Subsidiary's equity as measured in Parent's consolidated financial statements (this is the same amount as under Method 1). The difference between the cash received on exercise plus the amount included in equity from the recognition of the compensation cost (i.e., the grant-date fair value of the share-based payment) and the noncontrolling interest would be recognized as an increase or decrease to Parent's additional paid-in capital.

If the share options expire unexercised, no adjustment would be required.

Subsidiary's Separate Financial Statements

In the separate financial statements of Subsidiary, there would be no accounting for the share option grant because Parent is issuing the share options on Subsidiary shares it already owns. Further, the recipients of the share options are not employees of or service providers to Subsidiary, so the compensation cost would not be recorded in Subsidiary's separate financial statements.

If Parent had directed Subsidiary to issue new shares of Subsidiary to Parent's employees that were not providing services related to Subsidiary's operations, the grant-date fair value of the share awards granted to Parent's employees would be recognized in subsidiary's separate financial statements as a dividend distribution to Parent. See also Q&A 1.17 for another example of this situation.

Q&A 1.14: Subsidiary Shares Issued to Parent Employees and Nonemployees (Upstream Award)

Q. Parent distributes 10% of its holdings in Subsidiary to certain grantees (both employees and nonemployee service providers) of Parent as compensation for either delivery of goods or services rendered. The grantees are immediately vested in the award at the time of the distribution. Parent's book value and fair value in Subsidiary are \$100 and \$150, respectively. How should Parent account for the distribution?

A. In its consolidated financial statements, Parent should account for the distribution of shares under ASC Topic 718, recognize noncontrolling interest measured as Parent's book value in Subsidiary's equity, and the difference is recognized as an increase or decrease to Parent's additional paid-in capital. Because the distribution is shares rather than share options and the shares are immediately vested, the policy election described in

Q&A 1.12 is not applicable. In addition, there is no cost attribution difference for the employee and nonemployee awards, as the awards are immediately vested.

Parent records the following entries:

| | Debit | Credit |
|----------------------------|--------------|---------------|
| Compensation cost | 15 | |
| Noncontrolling interest | | 10 |
| Additional paid-in capital | | 5 |

Q&A 1.15: Share Option Awards Granted to a Director of a Subsidiary Who Is Also an Employee of the Parent

Q. The President of ABC Corp. serves on the Board of Directors of DEF Corp, a subsidiary of ABC. DEF grants share options to ABC's President for his service as a director of DEF. How should DEF account for the share options granted to ABC's President in its separate financial statements?

A. Because the share option award is being granted to the President for services to be provided to DEF in his capacity as a director, the share option award will be accounted for as an employee award and also accounted for as compensation cost to DEF rather than as a dividend distribution in the financial statements of DEF. Determining whether the share award is accounted for as an employee or nonemployee award will depend on the facts and circumstances. Determining whether the awards are accounted for as employee or nonemployee awards is important because it could result in different cost attribution for the award. This is because an entity is required to recognize compensation cost for nonemployee awards in the same manner as if the entity had paid cash in accordance with paragraph 718-10-25-2C. Additionally, valuation amounts for options could be different, as an entity may elect to use the contractual term as the expected term when valuing nonemployee share option awards.

If the DEF share options granted to the President are similar in amount to those granted to other elected directors of DEF, the awards would meet the criteria for employee awards under ASC Topic 718 and, accordingly, compensation would be measured using grant-date fair value and recognized over the vesting or service period. If the DEF share options granted to the President are significantly different from the share option awards granted to other elected directors of DEF, the awards in excess of those granted to other elected directors would likely be deemed to be for services beyond the services provided to DEF as a director.

As a consequence, DEF will need to determine whether the President provided additional services to DEF or to another entity within the consolidated group. To the extent that the President is receiving the additional awards for services provided to DEF, the entity would account for the awards as nonemployee awards in its separate financial statements.

Compensation would be measured using the grant-date fair value and recognized in the same manner as if the entity had paid cash.

Conversely, if the awards are for services to another entity within the consolidated group, in the separate financial statements of DEF the fair value of the awards would be recognized as a dividend distribution to the Parent.

Q&A 1.16: Effect of Shareholder Loans on Noncontrolling Interest

Background

Company B is a subsidiary of Company A. Company B entered into recourse promissory notes with its employees (outside the scope of ASC Topic 718), who used the proceeds to purchase shares of Company B. Company A is now calculating the effect of this transaction on noncontrolling interest in the consolidated financial statements.

Q. How should a full recourse loan on an employee purchase of shares of a subsidiary be treated in calculating noncontrolling interest?

A. This transaction has the following effect on Company A's consolidated financial statements, and would be treated differently in situations in which the promissory note is nonrecourse:

- Initial presentation - Following the guidance in ASC Topic 505, Equity, the promissory notes and issuance of Company B shares to employees are both recorded as adjustments to equity. As the result is the dilution of Company's A's interest in Company B, that equity adjustment is reflected in noncontrolling interest (NCI). NCI is increased for the issuance of new shares to employees and reduced with an offsetting deduction (i.e., contra) to NCI for the promissory notes. When the promissory notes are repaid, the contra NCI is removed.
- Allocation of earnings - The shares issued to employees have the same rights as all other issued shares. Therefore, the allocation of earnings between Company A's shareholders and NCI should reflect the proportionate ownership interests and should not include the promissory notes.
- Calculation of the dilution of Company A's interest in Company B – As prescribed by ASC Topic 810, *Consolidation*, Company A is required to calculate an adjustment to equity when its ownership in Company B is diluted and it retains control. Company A would calculate the equity adjustment based on the difference between the fair value of the consideration received and the percentage adjustment to the carrying value of NCI, excluding the effect of the contra NCI associated with the related loan, with any difference recognized in equity attributable to parent.

The issuance of equity to employees concurrent with a nonrecourse loan is required to be accounted for similar to an option under ASC paragraph 718-10-25-4. See Q&A 1.13 for additional guidance about the accounting for options of subsidiary shares.

1.017 Because the parent entity can direct a member of the consolidated group to grant awards to employees of other members of the consolidated group, awards granted by one member of the consolidated group to employees of another member of the group should be recorded in the grantor's separate financial statements as a dividend to the parent measured at the fair value of the award at the grant date. In its separate financial statements, the employer of the grantees should account for the awards to its employees as liability-classified (see Q&A 1.11) and would remeasure the award until settlement (see the discussion beginning at Paragraph 4.124 for discussion of the accounting for liability-classified awards). The employer of the grantees should recognize a corresponding credit to a liability until settlement, at which point the liability would be reclassified to equity to reflect a capital contribution from the parent. Correspondingly, in a subsidiary's separate financial statements, there would be a distribution.

Q&A 1.17: Share Option Awards Granted to Employees of the Parent to Purchase Shares of a Subsidiary's Stock

Q. ABC Corp. grants share options to the employees of the parent entity for the purchase of the common stock of one of its consolidated subsidiaries, DEF Corp. The shares to be issued upon exercise will be newly issued shares of DEF, and ABC will retain a controlling interest in DEF.

How should ABC account for the share options granted to the employees of the parent in its consolidated financial statements? How should DEF account for the share options granted to the employees in its separate financial statements?

A. In the consolidated financial statements, the awards will be accounted for as an employee award under ASC Topic 718. Q&A 1.13 describes a policy election available to ABC related to the presentation within equity as compensation cost is recognized during the requisite service period.

If share options expire unexercised, the amount recognized in noncontrolling interest should be reclassified from noncontrolling interest to ABC's additional paid-in-capital (i.e., the controlling interest) if Method 1 is used; or remain classified in ABC's additional paid-in capital if Method 2 is used.

In the separate financial statements of DEF, there is a dividend distribution to be recorded for the upward distribution of consideration for which DEF did not receive services. The amount of the dividend will depend on which entity receives the exercise proceeds. In this example, DEF would receive the exercise price upon settling of share options between ABC and the employees of the parent, given that the shares to be issued upon exercise will be newly issued shares of DEF. The amount of the distribution is the grant

date fair value of the share options. If ABC received and retained the exercise proceeds, the distribution to be recognized would be the grant date fair value of the underlying shares.

There is mixed practice related to the timing of *when* this distribution is recorded. We believe there are three acceptable policies that could be applied. First, DEF could record the distribution on the grant date of the awards. Second, DEF could record the distribution over the requisite service period following the attribution principles of ASC Topic 718. If either of these policies is followed, DEF would record a capital contribution if the awards are forfeited. Third, DEF could record the distribution on the exercise date (vesting date if the awards were shares). Under this third policy, there would be no accounting for the share options in DEF's separate financial statements during the vesting period as the employees do not provide service to DEF.

Employee Leasing Arrangements

1.018 For individuals who provide services to an entity (lessee) under a lease or co-employment agreement with another entity (lessor), the classification of an individual as an employee for payroll tax purposes is not relevant in determining whether the individual qualifies as an employee of the lessee. Rather, to qualify as an employee of the lessee, all of the following requirements must be met:

- (1) The leased individual qualifies as a common law employee of the lessee, and the lessor is contractually required to remit payroll taxes on the compensation paid to the leased individual for the services provided to the lessee.
- (2) The lessor and lessee agree in writing to all of the following conditions related to the leased individual:
 - (a) The lessee has the exclusive right to grant stock compensation to the individual for the employee service to the lessee.
 - (b) The lessee has a right to hire, fire, and control the activities of the individual. (The lessor also may have that right.)
 - (c) The lessee has the exclusive right to determine the economic value of the services performed by the individual (including wages and the number of units and value of stock compensation granted).
 - (d) The individual has the ability to participate in the lessee's employee benefit plans, if any, on the same basis as other comparable employees of the lessee.
 - (e) The lessee agrees to and remits to the lessor funds sufficient to cover the complete compensation, including all payroll taxes, of the individual on or before a contractually agreed-upon date or dates.

ASC Section 718-10-20

1.019 These objectives ensure that the lessee's relationship with the leased service provider is essentially the same as its relationship with employees of comparable status. Accordingly, to determine whether the grantee has the ability to participate in the lessee's employee benefit plans on the same basis as other comparable employees of the lessee, the benefits made available to the leased employee should be compared with benefits made available to other employees throughout the entity that have an equivalent level of responsibility and compensation.

1.020 In employee leasing or co-employment arrangements in which an individual qualifies as a common law employee of two employers with respect to the delivery of a single set of services, only one entity can qualify as the employer for financial reporting purposes. If the employee leasing criteria described in Paragraph 1.018 were met, the employer would be the lessee. However, this does not preclude an individual who is working part-time for two entities, providing separate services to each entity, from receiving share options from both entities and both awards being accounted for as employee awards by each entity.

Changes in Grantee Status

1.021 If a grantee ceases to provide service to the grantor (e.g., an employee terminates employment and becomes a nonemployee) and the award is either vested or not forfeited as a result of the change in status, the award would continue to be accounted for under ASC Topic 718 under its original terms, unless it is modified. As a result, an instrument that is issued to a grantee in exchange for goods or services received (or to be received) that is subject to the recognition and measurement guidance in ASC Topic 718 will continue to be subject to the recognition and measurement provisions of ASC Topic 718 throughout the life of the instrument (for both employee and non-employee share-based payment awards) up until a post-vesting award modification occurs when the awardee/grantee is either:

- No longer providing goods/services as a nonemployee;
- No longer a customer; or
- No longer an employee (see further discussion in Paragraph 3.083b about a conflict in Topic 718 regarding its ongoing applicability to employee awards that are modified after employment but before vesting).

See Section 5, *Modification of Awards*, for a discussion on accounting for modifications to the terms of share-based payment awards. If the terms of the award are modified, the grantor would need to assess whether the award would continue to be accounted for under ASC Topic 718, or subject to other GAAP (see Paragraph 3.088 for guidance on modifications to award instruments after they are subject to other GAAP). ASC paragraphs 718-10-35-10 and 35-11

Example 1.1a: Change in Grantee Status: Part I

On January 1, 20X8, ABC Corp. adopts ASU 2018-07. ABC grants a CFO 10,000 options that cliff vest at the end of five years for services to be received over those five years. The terms of the award provide that the grantee would retain the options on a change in employment status and continue to vest in the award. ABC estimates the grant-date fair value of the award to be \$15 per option, or \$150,000 or \$30,000 per year. On June 30, 20X9, when the fair value of the award is \$20, the grantee terminates employment and enters into a CFO outsourcing arrangement to provide ongoing substantive services as a nonemployee CFO. The grantee retains the options pursuant to the original terms in the agreement (i.e., the award was not modified in connection with the change in status and the original terms of the award provide for continued vesting in exchange for services rendered as a nonemployee).

At the time of the change in grantee status (June 30, 20X9), ABC had recognized \$45,000 of compensation expense (\$30,000 in Year 1, and \$15,000 in the first half of Year 2). The change in grantee status in this example does not result in a modification, as there has been no change to the terms of the award that would result in a change in fair value, vesting or classification (see Section 5). Attribution of the remaining compensation cost would follow the nonemployee attribution guidance prospectively from the date of the change in status—i.e., as if the grantor paid cash instead of issuing share-based payment awards. Therefore, ABC would continue to account for the awards under ASC Topic 718 and assuming the services provided by the CFO are relatively constant over the remaining 3.5 years, ABC would recognize \$15,000 for the second half of Year 2, and \$30,000 for each of the remaining 3 years.

Example 1.1b: Change in Grantee Status: Part II

Assume the same facts as Example 1.1a. However, on June 30, 20X9, when the fair value of the award is \$20, the grantee terminates employment and enters into a consultation arrangement to provide ongoing services as a nonemployee consultant. However, the services to be provided are “on-demand” that result in a few hours each quarter through December 31, 20Y3, and are not considered substantive. In addition, at the time of the change in grantee status, the award is modified so that it is fully vested on June 30, 20X9.

In this scenario, since the award was modified to change the vesting provisions, there is a modification to the award. While there is change in grantee status (employee to nonemployee), the services provided when the employee becomes a nonemployee are not associated with the award and would be accounted for separately. The modified award would continue to be accounted for under ASC Topic 718.

The modification would be treated as an improbable-to-probable modification in which the unvested options would vest immediately (see Paragraphs 5.008 and 5.037). ABC would recognize incremental compensation cost of \$155,000 ($\$20 \times 10,000 \text{ shares} =$

\$200,000 less \$45,000 already recognized compensation cost) immediately on June 30, 20X9.

Example 1.1c: Change in Grantee Status: Part III

On January 1, 20X8, ABC Corp. adopts ASU 2018-07. ABC grants the CFO 10,000 options that vest as of December 31, 20X9; however, the awards have a contractual term of 10 years. The terms of the award provide that the grantee on retirement has 60 days to exercise the vested option awards. On December 31, 20Y0, when the fair value of the award is \$25, the CFO retires. ABC subsequently modifies the option award plan to extend the exercise period to the full contractual term.

In this example, the modification would result in additional value because extending the exercise period post-retirement from 60 days to the full contractual term would result in a change in expected term, increasing the fair value of the share options. Because the modified awards are vested awards and the CFO (grantee) is no longer an employee or providing services, the awards would be accounted for under other GAAP (ASC Topic 815).

AWARDS IN SHARES OF A RELATED ENTITY

1.022 Employees may be granted share-based payment awards based not on shares of their legal employer but on a related entity. For example, employees of a subsidiary may be granted share options to acquire shares of the parent company, employees of a joint venture may be granted share options to acquire shares of an investor company, or employees of one subsidiary may be granted share options to acquire shares of a related subsidiary. Such awards raise a number of accounting issues in the preparation of both the consolidated financial statements and the separate financial statements of the subsidiary or investee. See the discussion beginning at Paragraph 1.013 about these accounting issues.

1.023 Accounting for share-based payments made to employees applies only to share options or awards in the shares of the employer (or that are deemed to be shares of the employer) granted to its employees. Determining the appropriate accounting for related entity awards involves a careful consideration of the facts. Awards to nonemployees of a grantee in shares of a related entity also involve careful consideration, including determining whether those awards are in the scope of ASC Topic 718.

Tracking Stock Awards

1.024 An entity may use *tracking stock* as the basis of a share award. Tracking stock is a class of shares associated with a specific business unit of an entity. In general, the earnings available for distribution to the holders of the tracking stock are based on the performance of that business unit. The issuance of tracking stock creates two (or more) classes of common shares, and holders of each class are shareholders of the parent entity. The unique characteristics of tracking stock raise questions about the appropriate accounting

for share-based payment awards in a tracking stock, which are not explicitly addressed in ASC Topic 718.

1.025 Awards based on tracking stock should be accounted for as equity awards of the parent if the tracking stock is substantive. If so, awards granted to employees or nonemployees of any consolidated subsidiary of the parent, not just the operations underlying the tracking stock, would be subject to the provisions of ASC Topic 718. Determining whether tracking stock is substantive requires evaluating all the relevant facts and circumstances, including the reasons for issuing the tracking stock, bona-fide third-party ownership of the tracking stock, and the voting rights of the shares compared with the rights of the parent's other common shares. Publicly traded tracking stock always is considered to be substantive. If tracking stock is not substantive, it is not considered equity for either the parent or the referenced operations (e.g., a separate subsidiary) for share-based payment purposes, and awards based on that tracking stock should be accounted for as either a cash-based award or as a formula-based arrangement.

Q&A 1.18: Share Options to Purchase Tracking Stock

Q. A company issues a substantive tracking stock based on a subsidiary's operations and grants share options to employees of the subsidiary to purchase the tracking stock. How should the company account for the share options in the consolidated and separate attributed financial statements?

A. Share options on tracking stock that are substantive should be considered awards in a class of the parent's equity. Accordingly, because the tracking stock is substantive, in both the consolidated financial statements and the separate attributed financial statements of the tracking stock, the awards would be accounted for as employee awards. Because the tracking stock is a class of parent equity, it would not give rise to noncontrolling interest, even upon exercise of the share options.

RELATED PARTIES AND ECONOMIC INTEREST HOLDERS

1.026 Equity instruments transferred by a related party or a holder of an economic interest in the entity to grantees of the entity are subject to the provisions of ASC Topic 718, unless the transfer was clearly for a purpose other than compensation (see Q&A 1.20). These arrangements are considered to be capital contributions to the entity by the related party or economic interest holder, with a subsequent award of equity instruments by the entity to its grantees in exchange for services rendered or goods received. Economic interests include any type of interest an entity could issue or be a party to, including equity securities; financial instruments with characteristics of equity, liabilities, or both; long-term debt and other debt-financing arrangements; leases; and contractual arrangements such as management contracts, service contracts, or intellectual property licenses. ASC Section 718-10-20 and ASC paragraphs 718-10-15-4 and 220-10-S99-4

Q&A 1.19: Transfer by an Economic Interest Holder

Q. Shareholder X owns a significant number of ABC Corp.'s shares. Shareholder X transfers some of the shares to employees of ABC. Is this transaction between Shareholder X and the employees of ABC within the scope of ASC Topic 718?

A. Yes. Because Shareholder X is an economic interest holder in ABC, equity transactions between Shareholder and employees of ABC are capital contributions from Shareholder X to ABC and equity awards from ABC to its employees, in exchange for services rendered.

Q&A 1.20: Share Transfer by an Economic Interest Holder for a Purpose Other Than Compensation

Q. Shareholder X owns a significant number of ABC Corp.'s shares. Shareholder X exchanges 1,000 shares in ABC with ABC's CEO for cash consideration equal to the fair value of the shares. Shareholder X enters into this transaction primarily to increase his liquidity to meet other obligations. ABC's CEO performed no services for either ABC or Shareholder X specifically related to this transaction. Is this transaction between Shareholder X and ABC's CEO within the scope of ASC Topic 718?

A. No. Although Shareholder X is an economic interest holder in ABC, this transaction was entered into for purposes other than compensation. This conclusion is further supported by the fact that the transaction was entered into at fair value. As a result, this transaction is not within the scope of ASC Topic 718 and it would not be recognized in ABC's financial statements.

Q&A 1.21: Share Transfer by an Economic Interest Holder for Less Than Fair Value – Part I

Q. Shareholder X owns a significant number of ABC Corp.'s shares. Shareholder X exchanges 1,000 shares in ABC with ABC's CEO for cash consideration that is significantly less than the fair value of the shares. Is this transaction between Shareholder X and ABC's CEO within the scope of ASC Topic 718?

A. Yes. Because Shareholder X is an economic interest holder in ABC and the transaction is not for purposes other than compensation, this transaction is within the scope of ASC Topic 718. The discount from fair value is a capital contribution from Shareholder X to ABC, and an equity award from ABC to its CEO.

Q&A 1.21a: Share Transfer by an Economic Interest Holder for Less Than Fair Value – Part II

Q. CEO, as a shareholder, (Shareholder X) owns a significant number of ABC Corp.'s shares. Shareholder X exchanges 1,000 shares in ABC with a supplier of ABC for cash consideration that is significantly less than the fair value of the shares. The transaction is not for purposes other than compensation. Is this transaction between Shareholder X and ABC's supplier within the scope of ASC Topic 718?

A. Yes. Because Shareholder X is an economic interest holder in ABC and the transaction is not for purposes other than compensation, this transaction is within the scope of ASC Topic 718. The discount from fair value is a capital contribution from Shareholder X to ABC, and also provides a compensatory non-employee award from ABC to its supplier.

Secondary Transactions

1.026a When a long period exists between an entity's startup phase and its IPO, some private companies enable transactions that permit common shareholders to sell a portion of their holdings to existing or new investors to obtain liquidity. These transactions are sometimes referred to as secondary offerings. Secondary offerings allow existing shareholders, often employees who received shares as share-based payment awards subject to ASC Topic 718, to monetize their holdings without diluting the holdings of other investors. The selling price in secondary offerings may exceed the fair value of the underlying share (i.e., a premium).

1.026b As discussed in Paragraph 1.026, if a related party or economic interest holder sells the entity's shares to an employee or nonemployee service provider, the transaction is within the scope of ASC Topic 718 unless the transfer is clearly for a purpose other than compensation. We believe this would also apply if the related party or economic interest holder *purchases* shares from grantees (or from a grantee selling shares not originally in the scope of ASC Topic 718). However, even if the purchaser is not a related party or economic interest holder, the transaction could still be in the scope of ASC Topic 718 depending on the company's involvement in the transaction. The following decision tree illustrates the key steps in evaluating whether a secondary transaction is compensatory:

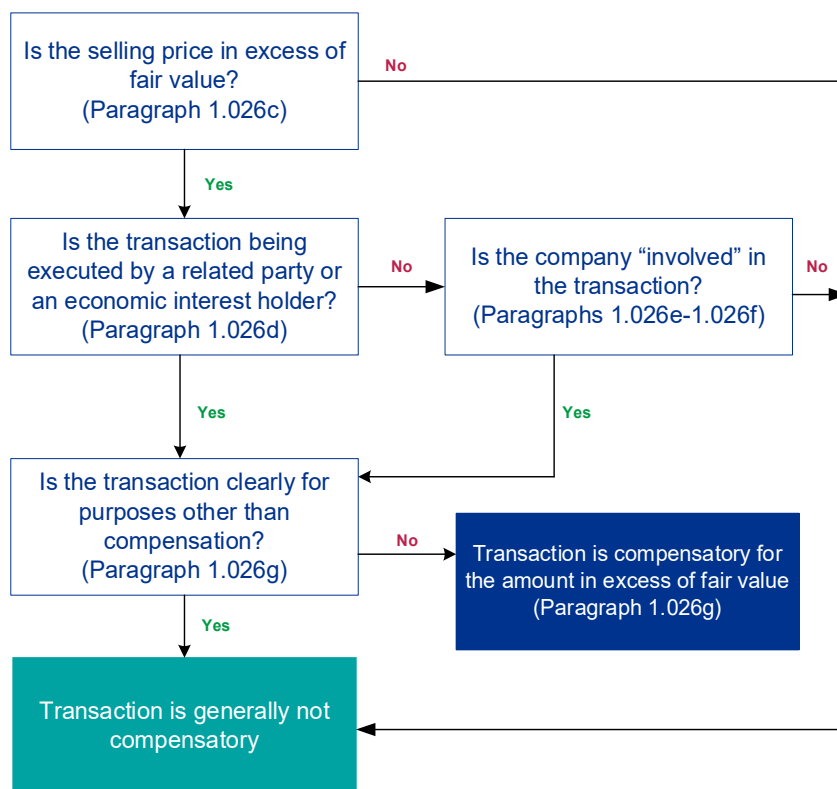

1.026c Typically, the first step in evaluating whether a secondary transaction has a compensatory element involves determining whether the purchase price exceeds fair value. That is because if the transaction is compensatory (see following paragraphs), the excess of the purchase price over fair value is compensation expense. Recording the excess over fair value as compensation expense is consistent with the accounting for settlements when the entity directly purchases shares from employees (see Paragraph 5.026). Evaluating whether secondary transactions are conducted at fair value can be complex and requires consideration of all relevant facts and circumstances. See Q&A 2.14a (Valuation Impact of Secondary Market Transactions) for further considerations of the impact on fair value of secondary transactions.

1.026d If the purchaser is a related party or economic interest holder, the purchase price in excess of fair value is compensation unless the transaction is clearly for purposes other than compensation. This is because the related parties or economic interest holders would be considered to be acting on the company’s behalf. See Paragraph 1.026 for types of arrangements that could make the purchaser an economic interest holder.

1.026e Even if the purchaser is not an economic interest holder, the purchaser may be acting on the company’s behalf and in the scope of ASC Topic 718. Whether a company is considered to be “involved” depends on the level of involvement and other relevant facts and circumstances. For example, if a company is directly involved in the secondary offering transaction (e.g., executes a tender offer to purchase the shares on behalf of investors), then the company would be considered to be “involved”. Conversely, if a

company's involvement is limited to only waiving its right of first refusal, then the company would not be considered to be "involved."

1.026f Other factors that indicate the company is "involved" in the secondary offering and the transaction is potentially compensatory include, but are not limited to:

- The company facilitates the transaction by providing incremental information to buyers about its financial performance, forecasts, business risks and current state of business condition with an intention to entice the new investors;
- The company facilitates the secondary offering at the same time as or in close proximity to a broader company financing transaction;
- The company facilitates the transaction by introducing potential new investors to selling common shareholders;
- The company sets the eligibility criteria and restricts participation in the secondary offering to only key employees; and
- Higher level company executives' or board members' involvement in the secondary offering.

1.026g If the purchase price is above fair value and the purchaser is a related party or economic interest holder, or if the company is "involved" in the secondary transaction, any excess above fair value would be compensatory unless clearly for a purpose other than compensation. We believe overcoming the presumption that the transaction is for a purpose other than compensation will be challenging.

1.026h While these transactions may be compensatory, such transactions may also:

- Affect how fair value is determined for subsequent share-based payment awards;
- Need to be considered when assessing the classification of awards (i.e., if purchased shares are "immature");
- Change the characterization of the secondary offering transaction for tax purposes; or
- Have other tax and accounting consequences.

Also see Q&A 2.14a (Valuation Impact of Secondary Market Transactions), Example 5.20a (Settlement of Vested Shares in a Secondary Offering), and Q&A 5.7c (Grantee Sales of Immature Shares in Secondary Offering).

Q&A 1.21b: Employee Sale of Vested Shares in a Secondary Offering

Q. ABC Corp. enters into a secondary stock offering (the Offering) allowing current employees of ABC to sell vested common shares at \$10 a share to Purchasers. Purchasers are existing shareholders of ABC. The fair value of the shares is \$5, determined by a

contemporaneous valuation of the common stock. The conclusion of the valuation analysis is broadly in line with other secondary offerings for the common shares that happened in reasonable proximity before the new financing round. As a result of the Offering, Purchasers acquire common stock for cash consideration that is significantly in excess of the fair value of the shares. Is this transaction between Purchasers and employees within the scope of ASC Topic 718?

A. Yes. Management should evaluate whether the transaction price Purchasers paid reflects fair value (see Q&A 2.14a), and whether additional compensation has been provided to the employees. A fair value transaction between an employee and a shareholder in mature, vested shares would generally be considered a transaction among shareholders with no accounting recognition by ABC. However, if the transaction price paid by Purchasers exceeds fair value, ABC should consider whether Purchasers are deemed to be acting on behalf of ABC. Since Purchasers hold prior economic interests in ABC, we believe that the Purchasers should be presumed to be acting on behalf of ABC and any excess purchase price above the stock's fair value represents compensation to employees for prior services under ASC Topic 718. The premium conveyed to employees would be accounted for as compensation expense and a contribution of capital by Purchaser in ABC's financial statements. The presumption that there is a compensatory element would be overcome only if ABC can demonstrate that the premium paid was clearly for another purpose. Tax ramifications of such transactions should also be evaluated.

While this example depicts a scenario for employee awards, the example could be applied to similar transactions with nonemployees or former employees, in that the transaction with nonemployees also could be in the scope of Topic 718.

Example 1.1d: Settlement of Vested Shares in a Secondary Offering

ABC Corp. requires new buyers of preferred stock that did not previously hold economic interests in ABC (the Buyers) to purchase employee common shares through a secondary offering to participate in a preferred stock offering. The Buyers acquire 1 million employee shares of common stock at \$10 per share as part of the secondary offering. A contemporaneous valuation of the common stock resulted in a fair value of \$3 per share. The conclusion of the valuation analysis is broadly in line with other secondary offerings for the common shares that happened in reasonable proximity before the new financing round. That value considered the \$10 secondary offering price as an input but weighted the other data points more heavily. See Q&A 2.14a.

As the transaction price of \$10 exceeds the \$3 fair value from the valuation, management of ABC must determine if the transaction to settle the employees' vested common shares was compensatory and therefore, whether the Buyers are deemed to be acting on behalf of ABC. ABC's level and nature of involvement in facilitating the settlement of the vested common stock in the secondary offering should be evaluated in determining whether the Buyers are acting on ABC's behalf. Given ABC's involvement in this

transaction (i.e., requiring the Buyers to purchase employee common shares through a secondary offering), the Buyers are deemed to be acting on behalf of ABC and the excess purchase price represents compensation to employees for prior services in ABC's financial statements.

EMPLOYEE SHARE PURCHASE PLANS

1.027 Some companies offer employees the opportunity to purchase company shares, typically at a discount from market price. Such plans are within the scope of ASC Topic 718 and give rise to compensation cost unless certain criteria are met. Section 11 provides a more comprehensive analysis of the types of typical plans and the accounting implications. ASC paragraph 718-50-25-1

1.028 An employee share purchase plan is noncompensatory (i.e., it does not give rise to recognizable compensation cost), only if it meets all three of the following criteria:

- (1) The plan meets either of the following conditions:
 - The terms of the plan are no more favorable than those available to all shareholders of the same class of share; or
 - Any purchase discount from the market price does not exceed the per-share amount of share issuance costs that would have been incurred to raise a significant amount of capital through a public offering;
- (2) Substantially all eligible employees may participate on an equitable basis. Additionally, restricting eligibility on a country-by-country or entity-by-entity basis would not result in a compensatory plan as long as all employees within each country or entity are treated the same (e.g., eligible to participate and given the same discount feature); and
- (3) The plan incorporates no option features other than the following:
 - Employees are permitted a short period of time (not exceeding 31 days) after the purchase price has been fixed to enroll in the plan;
 - The purchase price is based solely on the market price of the shares at the date of purchase, and employees are permitted to cancel participation before the purchase date and obtain a refund of amounts previously paid (such as through payroll withholdings).

1.029 The employee eligibility criteria should be minimal, such as requiring employment of greater than 20 hours per week or completion of six months of service, such that substantially all full-time employees are eligible to participate. ASC paragraph 718-50-25-1 and 55-34

1.030 In cases where a class of shares is designed for, and held exclusively by, current or former employees (or their beneficiaries), the terms of share purchase plans should be evaluated to determine if they are compensatory. For example, the manner in which these

shares are priced for purchases and sales may indicate that transactions are compensatory. If the purchase price for all shareholders is based on the same formula, then the plan is not compensatory. However, if an employee or group of employees can purchase shares at a discount from the formula price available to other shareholders, then the transaction is compensatory and the value of the discount should be recognized over the requisite service period. Also, if employees can purchase at the formula price but sell at a different formula, resulting in higher proceeds than are available to other classes of shareholders, the employee transactions are compensatory and the spread between the purchase and sale price should be recognized over the requisite service period. Changes to the formula price subsequent to the employee's purchase of shares are not in themselves compensatory. An award that at inception did not have compensatory features and a change that would render the award compensatory that was not anticipated by employer and employee at inception, would not be treated as compensatory solely by virtue of a change in the formula price subsequent to grant of the award; however, such changes should be reviewed to ensure they were not contemplated at the inception of the transaction. ASC paragraph 718-50-25-1(a)(1) and 55-35

1.031 There is a safe harbor level of 5% for the discount that an employer could offer an employee without the share purchase plan being considered compensatory. A plan that offers employees a discount in excess of the 5% level may be considered noncompensatory, if the employer can justify that the discount level is no greater than the cost it incurs when raising a significant amount of equity capital. However, for new grants, the entity should justify this conclusion for each significant equity offering and at least annually. If the level of discount cannot be justified or any of the other conditions are not met, the entire discount is considered compensation (rather than just the portion of the discount in excess of 5%), and the fair value of the entire award related to the plan is included in the calculation of share-based payment compensation cost. ASC subparagraph 718-50-25-1(a)(2)

1.032 A subsequent reassessment that a particular level of discount above 5% is no longer supportable does not cause existing grants to be reevaluated. However, it does mean that the discount cannot be used for supporting subsequent grants unless there are other changes in facts and circumstances. ASC paragraph 718-50-55-35

1.033 A number of the features common to share purchase plans are likely to cause those plans to be compensatory under ASC Topic 718, because many plans were designed to meet the IRS guidelines of a 15% discount. The level of discount is only one example. Another feature likely to cause a plan to be considered compensatory is the type of purchase-price optionality common to many plans.

1.034 A plan that establishes the purchase price of a share to an employee as an amount based on the lesser of the market price of the share, either at the date of grant or at the date of purchase, would cause the plan to be compensatory. These features are commonly referred to as look-back features. Likewise, a plan based on the market price of a share at grant date that enables an employee to cancel participation before the purchase date and receive a refund of contributions would also be compensatory. ASC paragraphs 718-50-25-1 and 25-2

Q&A 1.22: Employee Share Purchase Plan to All Employees and Shareholders

Q. ABC Corp. offers all eligible employees and all shareholders the right to purchase annually up to \$1,000 of its common shares at a 10% discount from the market price. Is this arrangement compensatory?

A. No. Because the terms of the arrangement are the same for all eligible employees and all shareholders of the same class of shares, substantially all employees are permitted to participate on an equitable basis, and there are no option features, the arrangement is not compensatory.

Q&A 1.23: Employee Share Purchase Plan with Differing Terms for Employees and Nonemployee Shareholders

Q. ABC Corp. offers all eligible employees the right to purchase annually up to \$1,000 of its common shares at a 10% discount from the market price. ABC also has a program that allows all shareholders to reinvest dividends to purchase up to \$1,000 of common shares at a 10% discount from the market price. Is the arrangement with the employees compensatory?

A. Yes. The value of the shareholders' arrangement is dependent on the number of shares held and the dividends declared, while the employees' arrangement is not. The employees' arrangement is more favorable than the arrangement for nonemployee shareholders and, therefore, the 10% discount in the employees' arrangement is compensatory.

Q&A 1.24: Compensatory Employee Share Purchase Plan Based on a Formula

Q. Company X, a privately held company, has Class B shares that are held exclusively by employees. Employees can purchase Class B shares at a price equal to book value per share and sell the shares at a price equal to 1.5 times book value per share. Class A shares are held by nonemployees. Class A shares can be purchased from and sold to the company at book value. Is this arrangement compensatory?

A. Yes. Because the employees can purchase shares at a different formula price than they can sell them and those terms are more favorable than for other shareholders, the purchase discount is compensatory and should be recognized over the requisite service period.

Q&A 1.25: Noncompensatory Employee Share Purchase Plan Based on a Formula

Q. Company X, a privately held company, has Class B shares that are held exclusively by employees. Employees can purchase and sell Class B shares at a price equal to book value per share, which is believed to approximate fair value. Two years later, Company X determines that its Class B shares are worth 1.5 times book value per share and changes the price accordingly. Is this increase compensatory for those employees that purchased shares at book value per share?

A. No. An increase in the formula *subsequent* to an employee buying shares is not compensatory.

AWARDS IN SHARES OF A NON-RELATED COMPANY

1.035 If the underlying shares of a share-based payment award are not the equity instruments of the granting entity or one of its affiliates, ASC Topic 718 does not apply. Such awards are accounted for under ASC paragraphs 815-10-45-10, and 55-46 through 55-48, which conclude that awards with underlying shares of an unrelated publicly traded entity are derivative financial instruments that should be accounted for under ASC Topic 815, *Derivatives and Hedging*. Accordingly, an entity should account for the grant as a derivative liability and mark it to fair value each period until the award is exercised, forfeited, or expires unexercised. For these awards, the ASC 815-10-55-46 through 55-48 paragraphs provide guidance on the derivative liability classification and accounting for the awards, and ASC 815-10-45-10 provides guidance for options granted to employees and nonemployees, in which a grantor would account for the changes in the fair value of the option award as compensation cost, prior to vesting. As a result, we believe it is reasonable that the recognition requirements in ASC 718 would be applied to the resulting compensation cost to be recognized prior to the award vesting. The fair value would be recognized over the employee's requisite service period or nonemployee's vesting period as compensation cost. After the award vests, the entity continues to mark the written option to fair value with changes in fair value recognized in net income until the award is settled. However, the EITF concluded that post-vesting changes in fair value may be reflected elsewhere than compensation cost.

1.036 For employee awards, some entities measure the fair value of the liability at each measurement date throughout the employee's requisite service period, but only record the product of the fair value of the award multiplied by the ratio that represents the portion of the requisite service period that has elapsed. Any adjustment since the last measurement is recorded as compensation cost. This accounting is similar to other liability-classified awards and is illustrated in Example 4.41. Other entities record the grant-date fair value of the derivative liability with an offsetting deferred compensation asset on the grant date. These amounts are then adjusted each period for the then-current fair value of the award, with a proportional amount of the deferred compensation asset recognized over the requisite service period as compensation cost. Example 1.2 illustrates this method.

1.037 Regardless of the method of accounting during the requisite service or vesting period, after the award has vested, all changes in fair value are recorded in earnings. The entity should elect a policy to classify the changes in fair value after the requisite service or vesting period has ended either as compensation cost or elsewhere in the income statement, which should be followed consistently.

Q&A 1.26: Share Options of an Unrelated Company

Q. ABC Corp. issues share options to purchase Company B shares, an unrelated publicly traded entity, to its employees. Is this transaction within the scope of ASC Topic 718?

A. No. ASC Topic 718 applies to issuances of an entity's own equity instruments. Because the award is based on the shares of an unrelated entity, ASC Topic 718 does not apply. According to ASC paragraphs 815-10-55-46 through 55-48, this award meets the definition of a derivative and should be accounted for based on ASC Topic 815.

Example 1.2: Recognition and Measurement of Share Options Granted on Stock of Unrelated Company

On January 1, 20X6, ABC Corp. grants share options to its employees to purchase 10,000 shares of Company B, an unrelated publicly traded entity. The exercise price of the share options is \$10, which equals the market price of the stock on the grant date. The fair value of the share options is \$4 at the grant date. All of the awards vest on December 31, 20X7. All of the share options are exercised on January 1, 20X9 when Company B shares have a market price of \$16 per share.

The fair value of the share options at the following dates was:

| | |
|-------------------|----------------------|
| December 31, 20X6 | \$6 per share option |
| December 31, 20X7 | \$5 per share option |
| December 31, 20X8 | \$8 per share option |

ABC would make the following entries to recognize the share-based payment arrangement:

January 1, 20X6

| | Debit | Credit |
|---------------------------|--------|--------|
| Prepaid compensation cost | 40,000 | |
| Derivative liability | | 40,000 |

December 31, 20X6

| | | |
|---------------------------|--------|---------------------|
| Prepaid compensation cost | 20,000 | |
| Derivative liability | | 20,000 ¹ |

| | | |
|---------------------------|---------------------|--------|
| Compensation cost | 30,000 ² | |
| Prepaid compensation cost | | 30,000 |

¹ [10,000 share options × \$6 per share option] - \$40,000

² [10,000 share options × \$6 per share option] × 1 year / 2 years

December 31, 20X7

| | | |
|---------------------------|---------------------|--------|
| Derivative liability | 10,000 ³ | |
| Prepaid compensation cost | | 10,000 |
| Compensation cost | 20,000 ⁴ | |
| Prepaid compensation cost | | 20,000 |

³ \$60,000 – [10,000 share options × \$5 per share option]

⁴ [10,000 share options × \$5 per share option] - \$30,000 (recognized in 20X6)

December 31, 20X8

| | | |
|----------------------|---------------------|--------|
| Compensation cost | 30,000 ⁵ | |
| Derivative liability | | 30,000 |

⁵ [10,000 share options × \$8 per share option] - \$50,000 (cumulative compensation previously recognized)

Note: Changes in fair value after vesting may be reported either as compensation cost or elsewhere in the income statement.

January 1, 20X9

| | | |
|--------------------------------|---------|---------|
| Investment in Company B shares | 160,000 | |
| Cash | | 160,000 |

To acquire shares required to issue upon exercise of the share options.

| | | |
|--------------------------------|----------------------|---------------------|
| Derivative liability | 80,000 ⁶ | |
| Cash | 100,000 ⁷ | |
| Investment in Company B shares | | 160,000 |
| Compensation cost | | 20,000 ⁸ |

⁶ To eliminate the derivative liability at its fair value [10,000 share options × \$8 per share option]

⁷ Receipt of the exercise price from the employees [10,000 share options × \$10 per share option]

⁸ This amount would be reported in the same income statement line item where changes in the fair value of the derivative liability were reported subsequent to vesting (i.e., 20X8). This \$20,000 credit represents the difference between the intrinsic value of the share options and the fair value on the exercise date. As a result of the early exercise of the share options, a credit is recorded in the income statement.

1.038 When an award of a share option issued on the stock of an unrelated company is granted to an employee who is retirement-eligible at the grant date, the award would be fully vested because the explicit service period is considered nonsubstantive (see Paragraph 4.058). For retirement-eligible employees, this means that the full amount of the award would be recognized at the grant date. ASC paragraphs 718-10-55-87 and 55-88

ESCROWED SHARE ARRANGEMENTS IN AN IPO

1.039 The typical structure of an escrowed share arrangement in an IPO involves shareholders placing an equal portion of their existing stock holdings into escrow before the IPO, whereby if specified performance goals are attained subsequent to the IPO, the shares are released on a pro rata basis to these shareholders. If the performance goals are not met, the shares held in escrow are canceled. The SEC staff's historical position on escrowed share arrangements in an IPO is that the escrowed share arrangement for those shareholders who were formerly or are currently affiliated with the company as employees, consultants, contractors, officers, or directors results in the recognition of compensation cost if the shares are released to those shareholders. This view essentially treats the arrangement as tantamount to a reverse stock split followed by a restricted stock award that vests on achievement of performance conditions.

1.040 The SEC staff clarified their view on overcoming the presumption that for certain shareholders these arrangements represent compensation in ASC paragraph 718-10-S99-2. The substance of the arrangement, including whether the arrangement was entered into for purposes unrelated to, and not contingent on, continued employment, should be considered in evaluating whether the presumption of compensation has been overcome. If the escrowed shares will be released or canceled without regard to continued employment, specific facts and circumstances may indicate that the arrangement is in substance an inducement made to facilitate the transaction on behalf of the company, rather than a compensation arrangement. In these cases the arrangement generally should be recognized and measured according to its nature and reflected as a reduction of the proceeds allocated to the newly issued securities. An escrowed share arrangement in which shares are automatically forfeited if employment is terminated would be compensation.

1.041 Consistent with the grant-date fair value measurement model for equity-classified awards under ASC Topic 718, the compensation cost would be measured for grantees as the fair value of the shares at the date the shares are placed into escrow. For shareholders participating in the arrangement who are not affiliated with the company and will not hold positions that could affect the financial results of the company, no compensation cost would be recognized for the shares released from escrow to those specific shareholders.

DEFERRED COMPENSATION ARRANGEMENTS

1.042 Deferred compensation arrangements permit employees to defer receipt of a portion of their current remuneration until a future date. The most common forms of deferred compensation arrangements include postretirement benefit plans (covered by ASC Topic 715, *Compensation—Retirement Benefits*), postemployment benefit plans (ASC Subtopic 712-10, *Compensation—Nonretirement Postemployment Benefits – Overall*), and

individual deferred compensation contracts (ASC Subtopic 710-10, *Compensation—General – Overall*). A detailed discussion of these arrangements is outside the scope of this book. In certain circumstances, an employee may defer receipt of share-based compensation to meet tax or retirement planning objectives. Under such arrangements, the settlement of the employer's obligation to the employee under the share-based compensation award is deferred until a future date.

1.043 Under some plans, an employee can elect to transfer shares received on exercise of share options into a deferred compensation plan. An employee also can defer receipt of other forms of compensation such as cash bonuses, stock appreciation rights, and restricted stock. If the election is structured properly, the employee also can defer recognition of the income for tax purposes until the amounts are distributed. The accounting implications to the employer of these elections depend on the terms of the deferred compensation arrangement and whether it is funded. The transfer of the obligation and funding, if any, to a trust (such as a rabbi trust) for later distribution to employees generally is not a substantive transfer for financial reporting purposes. A rabbi trust is a trust established by an employer to provide a source of funds that can be used to satisfy an employer's obligations to its employees. Because the trust assets are subject to the claims of the employer's general creditors in the event of bankruptcy, constructive receipt of the funds by the employee for tax purposes does not occur until the assets ultimately are distributed by the trust to the employee.

1.044 In ASC Subtopic 710-10, the Emerging Issues Task Force (EITF or Task Force) addressed the accounting for deferred compensation arrangements in which amounts earned by an employee are invested in the stock of the employer and the shares are placed in a rabbi trust. ASC Subtopic 710-10

1.045 In considering the accounting issues associated with these plans, the Task Force considered four scenarios:

- **Plan A.** The plan does not permit diversification and must be settled by the delivery of a fixed number of shares of employer stock.
- **Plan B.** The plan does not permit diversification and may be settled by the delivery of cash or shares of employer stock.
- **Plan C.** The plan permits diversification; however, the employee has not diversified (the plan may be settled in cash, shares of employer stock, or diversified assets).
- **Plan D.** The plan permits diversification and the employee has diversified (the plan may be settled in cash, shares of employer stock, or diversified assets).

1.046 The Task Force concluded that for all of the types of plans in Paragraph 1.045, the accounts of the rabbi trust should be consolidated by the employer in the employer's financial statements. Under ASC Subtopic 810-10, *Consolidation – Overall*, the trust is evaluated to determine whether it is a variable interest entity (VIE) and if so, whether the employer is the primary beneficiary. Based on the guidance in ASC Subtopic 810-10, a rabbi trust generally would be a VIE because the trust typically does not have equity; it

has a liability to the employee to whom the deferred compensation benefits are owed. Even if the trust has equity, it generally would be a VIE because the equity investment is not at risk because equity was provided to the employees by the employer. As a consequence, applying ASC Subtopic 810-10 generally will lead to a conclusion that the employer is the primary beneficiary of the VIE and is required to consolidate the trust. In the unusual circumstance that a rabbi trust is determined to be a non-VIE under the guidance of ASC Subtopic 810-10, the rabbi trust is evaluated under the guidance of ASC Subtopic 710-10 for consolidation. The consolidation guidance may not apply in instances in which financial assets are transferred to the rabbi trust because the financial assets may not be derecognized pursuant to the provisions of ASC Topic 860, *Transfers and Servicing*.

1.047 Accounting for the Assets of the Trust. The conclusions reached by the Task Force in ASC Subtopic 710-10 about the accounting for the assets in the various types of plans discussed in Paragraph 1.045 are explained in the following paragraphs.

1.048 Plan A. For Plan A, the shares of the employer stock held by the rabbi trust should be classified in equity similar to the manner in which treasury stock is accounted for. Therefore, subsequent changes in the fair value of the employer's stock should not be recognized. The deferred compensation obligation should be classified as an equity instrument and changes in the fair value of the amount owed to the employee should not be recognized.

1.049 Plan B and Plan C. For Plans B and C, the shares of the employer stock held in the rabbi trust should be classified in equity similar to the manner in which treasury stock is accounted for. Therefore, subsequent changes in the fair value of the employer's stock should not be recognized. However, the deferred compensation obligation should be classified as a liability and adjusted with a corresponding charge (or credit) to compensation cost, to reflect the changes in the fair value of the amount owed to the employee.

1.050 Plan D. For Plan D, assets held by the rabbi trust should be accounted for under the GAAP applicable to the particular asset (e.g., if the diversified asset is a marketable equity security, that security would be accounted for under ASC Subtopic 320-10, *Investments--Debt and Equity Securities - Overall*). The deferred compensation obligation should be classified as a liability and adjusted, with a corresponding charge (or credit) to compensation cost, to reflect changes in the fair value of the amount owed to the employee. Changes in the fair value of the deferred compensation obligation should not be recorded in other comprehensive income, even if changes in the fair value of the assets held by the rabbi trust are recorded, under ASC Subtopic 320-10, in other comprehensive income. However, the Task Force observed that, at acquisition, securities held by the rabbi trust may be classified as trading to provide symmetry in the recognition of the obligation and the ASC Subtopic 320-10 security in earnings. The trading securities would be classified as either current or noncurrent, based on the provisions of ASC paragraphs 210-10-45-1 through 45-4.

1.051 Dividends. Some deferred compensation arrangements that are funded through a rabbi trust that includes shares of stock of the employer permit the employee to retain dividends paid on those shares. If dividends are paid on the shares in the rabbi trust and retained in that trust solely as cash, there is mixed practice as to whether this disqualifies the continued use of Plan A accounting. Some believe that it would disqualify the plan because what would be delivered (the shares plus cash for the accumulated dividends) is something other than a fixed number of employer shares. Others believe that it should not disqualify the plan because under the principles of share-based payment accounting, the accounting for dividends is incorporated into value and does not generally affect the classification of the underlying awards. If disqualified from Plan A accounting (either by policy election as described above or because the plan allows the employee to invest the cash into other securities), the arrangement would be accounted for as a Plan D arrangement. To avoid the possibility of being disqualified from using Plan A accounting, some companies establish a separate trust for the dividends. If Plan A accounting is retained for the original rabbi trust, the dividends paid and accumulated in the separate trust would be recognized by the entity as either:

- **Retained Earnings.** Consistent with the premise of ASC Topic 718 that the future dividends have been captured in the grant-date fair value measure of the award, the dividends paid and accumulated in a rabbi trust are recognized as a charge to retained earnings. This accounting treatment is similar to how one would account for dividends on other nonvested share awards where the dividends paid are charged to retained earnings to the extent that the awards are expected to vest; or
- **Compensation Cost.** Consistent with the premise of ASC Subtopic 710-10 that a Plan A-type arrangement is accounted for in a manner similar to treasury stock, payment of dividends would not be part of the arrangement because dividends are not paid on treasury stock. Under this approach, dividends would be recognized as additional compensation cost.

The entity should adopt and apply its policy on a consistent basis to all Plan A rabbi trust arrangements.

1.052 Consistent with the guidance on dividends received on securities accounted for under ASC Subtopic 320-10, an entity accounting for a rabbi trust based on Plan D accounting should recognize the dividends paid to the rabbi trust as compensation cost. Under Plan D accounting, the deferred compensation obligation should be classified as a liability and adjusted, with a corresponding charge (or credit) to compensation cost to reflect changes in the fair value of the amount owed to the employee.

PROFITS INTERESTS AND SIMILAR AWARDS (AFTER ADOPTION OF ASU 2024-01)

1.053 An award of ownership interests in partnerships, limited liability partnerships (LLPs), or limited liability corporations (LLCs) is generally within the scope of ASC Topic 718. The definition in ASC Section 718-10-20 of the term *shares* “includes various forms of ownership interest that may not take the legal form of securities (e.g., partnership

interests), as well as other interests, including those that are liabilities in substance but not in form.”

1.054 Some pass-through entities grant share-based payments to employees using instruments that generally qualify as *profits interests* for tax purposes. However, this term can be used to refer to a wide range of arrangements and/or take on a variety of legal forms. Given the variety of arrangements and different legal forms, a profits interest or similar award could be (1) a share-based payment arrangement accounted for under ASC Topic 718, or (2) in substance, a bonus or profit-sharing arrangement accounted for under ASC Subtopic 710-10.

1.055 For tax purposes, a profits interest unit is defined as a partnership interest other than a capital interest and the holder would receive no proceeds if the partnership were immediately liquidated at the time of receipt of the partnership interest. While the profits interest holder often does not have immediate liquidity (e.g., amounts are paid to the interest holder only on the occurrence of a liquidity event), the award has value to the holder due to the *upside* potential and an award in ASC Topic 718 is measured at the grant date to recognize compensation cost. In determining the fair value of profits interests, it is inappropriate to assume immediate liquidation of the interests. Instead, the valuation should be based on future cash flows to which profits interest holders will be entitled under the specified terms for cash distributions. This is similar to the valuation of common stock in a closely held entity when preferred stockholders have distribution preferences and common shareholders only share in appreciation or cash flows beyond a *hurdle* amount. See Paragraph 2.161, “Valuation Techniques to Establish Enterprise Value” for additional discussion on this concept.

1.056 ASC Topic 718 does not define a profits interest nor does it explicitly state whether awards of profits interests or similar instruments are in the scope of ASC Topic 718. Instead, it contains the following four cases (“Cases”) that illustrate how scoping paragraph 718-10-15-3 (see Paragraph 1.000) is evaluated for profits interests or similar awards. For guidance on evaluating profits interest awards before adoption of ASU 2024-01, *Compensation—Stock Compensation (Topic 718): Scope Application of Profits Interest and Similar Awards*, see discussion beginning at Paragraph 1.066. See Section 8, for transition guidance on ASU 2024-01.

Excerpt from ASC 718-10-55-138 through 55-148

55-138 This Example illustrates how an entity should apply the guidance in paragraph 718-10-15-3 to determine whether a profits interest or similar award is a share-based payment arrangement and is within the scope of this Topic or is not a share-based payment arrangement and, therefore, is within the scope of other Topics. The guidance in this Example is limited to the application of paragraph 718-10-15-3 and does not address how to apply other Sections of this Topic, including recognition, classification, initial measurement, subsequent measurement, other presentation matters, and disclosure.

55-139 Cases A, B, C, and D share the following assumptions:

- a. Entity X is a partnership. Before June 1, 20X1, Entity X had Class A units outstanding. On June 1, 20X1, Entity X grants Class B incentive units to employees of a subsidiary of Entity X in exchange for services.
- b. An exit event may include an initial public offering, a change in control, or a liquidation of Entity X's assets.

· · > Case A: Award Is a Share-Based Payment Arrangement

55-140 Additional assumptions are as follows:

- a. The Class B units are profits interest units that are subordinated to the Class A units because after vesting they participate pro rata with the Class A units once the holders of the Class A units have received distributions equal to a predetermined distribution threshold established on the grant date of the Class B units.
- b. The Class B units cliff vest at the end of three years of service.
- c. Upon an exit event, the Class B units vest immediately if a grantee is still providing services to the subsidiary of Entity X. Upon such an event, the grantee would retain the vested Class B units, or if Class B units are settled through the exit event, Entity X would distribute proceeds to the Class B unit holders in the same manner as is described in (a).
- d. If a grantee of the Class B units terminates employment with the subsidiary of Entity X (whether voluntarily, upon death, disability, or retirement or at the election of Entity X for reasons other than cause), any unvested Class B units will be forfeited for no consideration. If a grantee of the Class B units terminates employment after vesting, the grantee retains ownership of the vested Class B units, but upon the grantee's termination of employment, Entity X has a call right to repurchase the Class B units. If the call right is exercised, Entity X would pay the grantee of the Class B units an amount of cash equal to the fair value of the Class B units on the call date.

55-141 Entity X evaluates the conditions in paragraph 718-10-15-3 to determine whether to account for the Class B units by applying the guidance in this Topic. The Class B units meet the condition in paragraph 718-10-15-3(a) because both of the following indicate that Entity X is offering to issue shares or other equity instruments:

- a. Either upon three years of service or an exit event, the grantor will have received the agreed-upon consideration (that is, the service will have been provided and the performance condition will have been met, if applicable) and the award will vest.

- b. Holding the vested Class B units provides the grantee with the right to participate in the residual interest of Entity X through periodic distributions, upon an exit event, or upon settlement proportionate to ownership of Class B units of Entity X in accordance with the distribution waterfall described in paragraph 718-10-55-140(a).

Therefore, Entity X would account for the Class B units by applying the guidance in this Topic.

· · > Case B: Award Is a Share-Based Payment Arrangement

55-142 Additional assumptions are as follows:

- a. The Class B units are profits interest units that are subordinated to the Class A units because once granted, they participate pro rata with the Class A units once the holders of the Class A units have received distributions equal to a predetermined distribution threshold established on the grant date of the Class B units.
- b. The grantee of the Class B units is eligible to begin participating in nonforfeitable operating distributions at the grant date.
- c. The Class B units only vest upon an exit event. Upon such an event, the grantee would retain the vested Class B units, or if Class B units are settled through the exit event, Entity X would distribute proceeds to the Class B unit holders in the same manner as is described in (a). Class B units are forfeitable upon the grantee's termination for any reason at any time before an exit event.

55-143 Entity X evaluates the conditions in paragraph 718-10-15-3 to determine whether to account for the Class B units by applying the guidance in this Topic. The Class B units meet the condition in paragraph 718-10-15-3(a) because both of the following indicate that Entity X is offering to issue shares or other equity instruments:

- a. Upon an exit event, the grantor will have received the agreed-upon consideration (that is, the service will have been provided and the performance condition will have been met) and the award will vest.
- b. Holding the vested Class B units provides the grantee with the right to participate in the residual interest of Entity X through periodic distributions, upon an exit event, or upon settlement proportionate to ownership of Class B units of Entity X in accordance with the distribution waterfall described in paragraph 718-10-55-142(a).

Therefore, Entity X would account for the Class B units by applying the guidance in this Topic.

55-144 The grantee of the Class B units is not entitled to retain the units if the grantee ceases to provide services before an exit event. Upon termination of employment before

an exit event, the grantee of the Class B units would forfeit all rights to future distributions and would forfeit Class B units for no consideration. Entity X would account for the grantee's right to participate in nonforfeitable operating distributions in accordance with paragraph 718-10-55-45.

· · > Case C: Award Is a Share-Based Payment Arrangement

55-145 Additional assumptions are as follows:

- a. The Class B units do not entitle the grantee to receive equity instruments of Entity X. This type of unit is often referred to as a phantom share unit.
- b. The grantee of the Class B units is not eligible to participate in distributions in the ordinary course of business.
- c. The grantee of the Class B units is eligible to receive cash upon an exit event. Upon an exit event, the Class B units vest immediately and must be settled in cash on the basis of the fair value of the Class B units. The fair value of the Class B units is calculated by reference to the price of Class A units of Entity X as determined at the date of the exit event.
- d. The grantee of the Class B units must be providing services when the exit event occurs to receive any proceeds, and the Class B units are forfeitable upon the grantee's termination for any reason at any time before an exit event.

55-146 Entity X evaluates the conditions in paragraph 718-10-15-3 to determine whether to account for the Class B units by applying the guidance in this Topic. The Class B units do not meet the condition in paragraph 718-10-15-3(a) because they do not entitle the grantee to receive shares or other equity instruments of Entity X; therefore, Entity X is not issuing, or offering to issue, shares, share options, or other equity instruments. However, the condition in paragraph 718-10-15-3(b)(1) is met because the cash proceeds received by the grantee upon settlement in an exit event are based, at least in part, on the price of Entity X's shares. Therefore, Entity X would account for the Class B units by applying the guidance in this Topic.

· · > Case D: Award Is Not a Share-Based Payment Arrangement

55-147 Additional assumptions are as follows:

- a. The Class B units do not entitle the grantee to receive equity instruments of Entity X. This type of unit is often referred to as a phantom share unit.
- b. The grantee of the Class B units is eligible to participate in operating distributions made by Entity X equal to 1 percent of the preceding fiscal year's net income. The grantee of the Class B units is eligible to begin participating in these operating distributions after three years of service.

- c. The grantee of the Class B units is not eligible to participate in any proceeds distributed upon an exit event.
- d. The Class B units are forfeitable upon the grantee's termination for any reason at any time (including after the grantee has rendered three years of service).

55-148 Entity X evaluates the conditions in paragraph 718-10-15-3 to determine whether to account for the Class B units by applying the guidance in this Topic. The Class B units do not meet the condition in paragraph 718-10-15-3(a) because they do not entitle the grantee to receive shares or other equity instruments of Entity X; therefore, Entity X is not issuing or offering to issue shares, share options, or other equity instruments. In addition, the condition in paragraph 718-10-15-3(b)(1) is not met because the proceeds received by the grantee related to operating distributions are based on an operating metric (1 percent of the preceding fiscal year's net income) of Entity X and are not based, at least in part, on the price of Entity X's shares. Furthermore, the condition in paragraph 718-10-15-3(b)(2) is not met because there is no circumstance in which Entity X would be required to issue its equity shares or other equity instruments. Therefore, Entity X would not apply the guidance in this Topic to account for the Class B units and, instead, would account for the Class B units in accordance with other Topics.

1.057 Cases A and B illustrate awards that are in the scope of ASC Topic 718 because the entity is issuing shares or other equity instruments to employees in exchange for services and thus the awards meet the condition in subparagraph 718-10-15-3(a). Case C illustrates an award where the entity does not issue shares or equity instruments but the award is in the scope of ASC Topic 718 because the entity incurs a liability based in part on the price of its shares (subparagraph 718-10-15-3(b)(1)). Case D illustrates an award that does not meet any of the conditions in paragraph 718-10-15-3 to be in the scope of ASC Topic 718.

1.058 While the Cases only illustrate the application of ASC paragraph 718-10-15-3 for four specific fact patterns, and ASC Topic 718 does not provide a principle or comprehensive list of factors to consider, the Cases highlight how entities should work through the scoping paragraph. In particular, the Cases highlight key factors that indicate whether the entity is issuing shares or other equity instruments to meet the condition in subparagraph 718-10-15-3(a) or 718-10-15-3(b)(2). These factors are consistent with general practice before ASU 2024-01.

1.059 Based on the Cases, we believe the following factors are the key indicators that the entity is issuing shares or other equity instruments to employees and the award meets the condition in subparagraph 718-10-15-3(a):

- (1) The legal form of the profits interest or similar award is an equity unit of the entity.
- (2) The arrangement provides the employee with rights associated with having an ownership interest in the entity, such as:
 - (a) Participation in fair value fluctuations of the entity (even if this is subject to senior classes of equity and a specified waterfall).

- (b) Claims to the residual net assets of the entity upon dissolution or liquidation proportionate to other equity holders (and subordinate to debt holders and other creditors).
 - (c) Rights to the residual returns of the entity's net assets through distributions proportionate to the ownership interest.
- (3) Subject to vesting conditions, the employee either retains his or her rights under the arrangement upon termination of service or the instrument is subject to repurchase at fair value (or, for some awards in nonpublic entities, a formula value that serves as a proxy for fair value).

1.060 In paragraph BC26 of ASU 2024-01, the FASB stated that the Cases are not intended to be all-inclusive and entities should consider all relevant information and apply judgment when determining whether a profits interest or similar award should be accounted for in accordance with ASC Topic 718. Other factors, which may or may not be present in the profits interest arrangement, may also be considered but are usually not given as much weight as the factors listed above. Such other factors include:

- (1) The employee is required to make an *initial investment* (i.e., an injection of capital into the entity either at the inception of the arrangement or on the occurrence of a vesting provision).
- (2) The employee is exposed to the risk of loss of the initial capital investment in the event of dissolution or liquidation of the entity.
- (3) The employee is afforded proportionate voting rights.
- (4) After vesting, the rights under the arrangement are transferable to another party.
- (5) Management's intent is to provide the employee an equity ownership interest in the entity.
- (6) The employees have the right to maintain their proportionate ownership through potential future issuances of common stock (i.e., pre-emptive rights).
- (7) The employees have the right or the obligation to participate on a proportionate basis with the controlling unitholder's exit from the business (sometimes referred to as *drag-along* or *tag-along* rights).

1.061 As discussed in Paragraph 1.059, the legal form of the profits interest or similar awards is an important factor to determine if the entity is issuing equity to a grantee. However, in paragraph BC16 of ASU 2024-01, the FASB indicated that it decided not to clarify whether legal form was determinative to avoid unintended consequences such as suggesting that the scope is based solely or predominantly on legal form rather than a complete evaluation of all the information. Therefore, while we believe the interest must be legal form equity to meet the conditions in subparagraph 718-10-15-3(a); other factors that indicate the award has characteristics of equity must also be present to conclude the entity is issuing shares or other equity instruments. For example, in Cases A and B, in addition to the interests being legal form equity, other factors discussed in Paragraph

1.059 were present. See Q&A 1.27 for an illustration of an award that is equity in legal form but is not in the scope of ASC Topic 718.

1.062 Even if legal form equity is not issued, the award could still be in the scope of ASC Topic 718 if the entity incurs a liability for which the amount is based, at least in part, on the price of the entity's own shares. For example, in Case C, Entity X issues phantom shares that are not legal form equity, but those shares entitle the grantee to an amount calculated by reference to other shares of Entity X. In contrast, Case D illustrates an award where legal form equity is not issued and the payments to which the grantee is entitled are not based, at least in part, on Entity X's other shares. Therefore, the award does not meet any of the conditions in ASC Topic 718.

1.063 When a profits interest award is not in the scope of ASC Topic 718, the conditions in paragraph 718-10-15-3 are not met because the award does not have the characteristics of a share-based payment and in substance the award is more akin to a profit-sharing or deferred compensation arrangement accounted for in accordance with ASC Subtopic 710-10. The following are factors often present in a profits interest award not in the scope of ASC Topic 718:

- (1) Even after fulfilling any stated vesting conditions, the rights to share in distributions are tied to continued employment in a manner such that the grantee never truly vests or becomes an owner of a share or other equity interest. Mechanisms that are activated on termination of employment that could be embedded in the arrangement and would indicate a profit-sharing or deferred compensation arrangement include:
 - (a) Automatic termination of any rights and/or return of units for no or nominal consideration.
 - (b) A repurchase feature at the option of either the entity or the employee (put/call) based on a formula that is not representative of a valuation technique that would approximate the fair value of the entity (i.e., the formula represents a mechanism for a profit sharing or bonus plan), or
 - (c) A call option (option is with the entity) that is in substance a forfeiture provision (see Paragraph 3.038).

The entity's right to repurchase the profits interest at fair value is not considered to be an indicator of a profit-sharing or deferred compensation plan because the employee is exposed to the ownership-type risks of changes in the value of the entity.

- (2) There are creditor-like features embedded in the profits interest such as a fixed redemption date or a specified return.
- (3) Management's intent is to provide a performance bonus by allowing the employee to share in profits and distributions of the entity only during employment.
- (4) The profits interest plan is used as an alternative to a cash bonus to obtain preferential tax treatment.

- (5) The profits interest plan requires little or no initial investment. The lack of initial investment is a common attribute of many types of profits interest plans and other types of stock compensation arrangements. As a result, this factor is considered to be of lesser importance than other factors in concluding on the overall substance of the plan.

1.064 The following Q&As illustrate the application of the scope paragraphs for profits interests and similar awards.

Q&A 1.27: Award of Profits Interests – Not in the Scope of ASC 718

Background

An LLC grants Class C units to employees with a three-year service condition. Upon vesting, the terms of the Class C units provide for a cash payment to the employees equal to 5% of the increase in the book value of the LLC. The employees are not required to make a capital contribution to receive the Class C units. When an employee leaves the LLC (whether for voluntary termination, death, disability, or retirement), the Class C unit is forfeited, and it becomes available to be distributed to other employees.

Q. Is the Class C unit a share-based payment?

A. No. None of the conditions in ASC paragraph 718-10-15-3 are met.

The LLC does not meet the condition in subparagraph 718-10-15-3(a) because, while the Class C unit is legal form equity, the following indicate the LLC is not issuing, or offering to issue, its shares or other equity interests:

- The arrangement does not provide the employee with rights associated with having an ownership interest in the entity and the employees do not have an investment at risk;
- The employee does not retain his or her rights under the arrangement on termination of service. The award is always forfeited when an employee leaves, regardless of how long the employee has been employed with the LLC; and
- The rights to share in distributions are tied to continued employment.

This award also does not meet any of the criteria in subparagraph 718-10-15-3(b) because the payments are not based in part on the LLC's shares, but rather on increases in book value of the LLC, and the entity is not obligated to satisfy a liability by issuing its shares.

As such, the award is not in the scope of ASC Topic 718 and it is treated as a profit-sharing arrangement, under which the employees have the right to receive a cash bonus in an amount equal to a specified percentage of the LLC's profits for the year. Therefore, the LLC should account for the award as a profit-sharing arrangement and should recognize compensation cost based on the amount to which the employees are entitled each period.

Q&A 1.28: Award of Profits Interests – In the Scope of ASC Topic 718 (1)**Background**

An employee is granted a Class B profits interest award in its LLC employer. The membership interests vest ratably over a four-year period. If the employee terminates employment, the unvested membership interests will be forfeited for no consideration. The employer has a call option to repurchase vested units at fair value. In addition, the terms of the repurchase feature provide the LLC the ability to delay repurchase until the employee has been exposed to risks and rewards of ownership for a reasonable period of time.

The LLC's organizing documents describe a waterfall as to how the fair value of the entity will be allocated to the different classes of equity as follows:

- d. Return of capital invested to the Class A units;
- e. Compounded rate of return at 12% to the Class A units;
- f. Residual amount shared proportionately between the Class A units and the Class B profits interests.

Q. Is this unit a share-based payment?

A. Yes. The condition in subparagraph 718-10-15-3(a) is met because the following indicate the LLC is offering to issue shares or other equity instruments:

- The employee is entitled to participate in the residual net assets of the entity upon dissolution or liquidation proportionate to Class A profits interests.
- The employee has an interest in the net assets of the LLC at grant date (i.e., the arrangement provides the employee with rights associated with having membership interest in the LLC).
- The employee retains his or her vested membership interest under the arrangement upon termination of service, subject to repurchase at fair value by the employer.

Q&A 1.29: Award of Profits Interests – In the Scope of ASC Topic 718 (2)

An LLC issues profits interest units to employees that vest ratably over a three-year service period. The units also vest in full on the occurrence of a Fundamental Change, which is defined as (a) a sale or merger, (b) acquisition of 50% or more of the voting rights by an unaffiliated party, or (c) dissolution or liquidation of the entity.

The Limited Liability Agreement specifies that cash distributions will be made first to members. The declaration and payment of distributions to members and award holders is

solely within the discretion of the managing member. Once a pre-determined rate of return has been met for the members, excess earnings may be distributed to profits interests unit holders. To be entitled to distributions on the profits interest when paid, the award must be *vested* at the time the distribution is paid and the employee must remain employed.

All profits interests units that have not yet vested will automatically be forfeited for no consideration if an employee is terminated for any reason before the occurrence of a Fundamental Change. The LLC agreement also provides that any award, whether vested or unvested, is forfeited for no consideration if the employer/employee relationship ceases before a Fundamental Change.

If the employee remains employed at the date of a Fundamental Change, unvested profits interest units vest and the employee will participate in the residual net assets of the LLC pursuant to a waterfall stated in the LLC agreement, regardless of whether the employee continues to remain employed after that date.

Q. Is this unit a share-based payment?

A. Yes. The condition in paragraph 718-10-15-3(a) is met because the following indicate the LLC is offering to issue shares or other equity instruments:

- Upon a Fundamental Change, the grantee will vest in the units, and the units will not be forfeitable.
- The profits interest units entitle the employee to the right to participate in the residual net assets of the LLC.

The three-year vesting period is nonsubstantive, because the employee can forfeit the award and rights to any distributions if employment ceases after vesting but before a Fundamental Change occurs. The substantive vesting condition for this award is the occurrence of a Fundamental Change while the employee remains employed.

The LLC would account for any nonforfeitable distributions paid prior to the Fundamental Change in accordance with paragraph 718-10-55-45. For further discussion on the accounting for dividends on unvested awards, see Paragraph 4.122.

AWARDS OF PROFITS INTERESTS TO EMPLOYEES (BEFORE ADOPTION OF ASU 2024-01)

1.065 An award of ownership interests in partnerships, limited liability partnerships (LLPs), or limited liability corporations (LLCs) is generally within the scope of ASC Topic 718. The definition in ASC Section 718-10-20 of the term *shares* “includes various forms of ownership interest that may not take the legal form of securities (e.g., partnership interests), as well as other interests, including those that are liabilities in substance but not in form.” For guidance on evaluating profits interest awards after adoption of ASU 2024-

01, *Compensation—Stock Compensation (Topic 718): Scope Application of Profits Interest and Similar Awards*, see discussion beginning at Paragraph 1.053.

1.066 Some pass-through entities grant share-based payments to employees using instruments that generally qualify as *profits interests* for tax purposes. However, this term can be used to refer to a wide range of arrangements and/or take on a variety of legal forms. When determining the appropriate accounting, the terms of the award – which may be embedded in a combination of a plan document, award letters, and the organizing documents of the entity - should be considered. All facts and circumstances surrounding the award should be considered in making that judgment. Specific emphasis is usually directed toward three key items. They are:

- (1) Whether the underlying economic rights conveyed in the instrument allow the employee to participate in changes in fair value of the entity similar to a residual equity interest;
- (2) The nature of any service, performance and market conditions as well as how they interact with one another; and
- (3) The nature of any repurchase provisions and their potential impact on the classification of the awards as equity or liabilities.

1.067 As it relates to understanding the economic rights the instrument conveys, profits interests typically are considered to represent one of two different types of compensation: (1) a share-based arrangement accounted for under ASC Topic 718, or (2) a bonus or profit-sharing arrangement accounted for under ASC Subtopic 710-10.

The following factors are the most common positive indicators that the arrangement is a share-based arrangement that should be accounted for under ASC Topic 718:

- (1) The legal form of the arrangement represents an equity unit of the entity.
- (2) The arrangement provides the employee with rights associated with having an ownership interest in the entity, such as:
 - (a) Participation in fair value fluctuations of the entity (even if this is subject to senior classes of equity and a specified waterfall).
 - (b) Claims to the residual net assets of the entity upon dissolution or liquidation proportionate to other equity holders (and subordinate to debt holders and other creditors.
 - (c) Rights to the residual returns of the entity's net assets through distributions proportionate to the ownership interest.
- (3) Subject to vesting conditions, the employee either retains his or her rights under the arrangement upon termination of service or the instrument is subject to repurchase at fair value (or, for some awards in nonpublic entities, a formula value that serves as a proxy for fair value).

The following factors, which may or may not be present in the profits interests arrangement, are usually not weighted as much as the factors listed above when evaluating the substance of the arrangement:

- (1) The employee is required to make an *initial investment* (i.e., an injection of capital into the entity either at the inception of the arrangement or on the occurrence of a vesting provision).
- (2) The employee is exposed to the risk of loss of the initial capital investment in the event of dissolution or liquidation of the entity.
- (3) The employee is afforded proportionate voting rights.
- (4) After vesting, the rights under the arrangement are transferable to another party.
- (5) Management's intent is to provide the employee an equity ownership interest in the entity.
- (6) The employees have the right to maintain their proportionate ownership through potential future issuances of common stock (i.e., pre-emptive rights).
- (7) The employees have the right or the obligation to participate on a proportionate basis with the controlling unitholder's exit from the business (sometimes referred to as *drag-along* or *tag-along* rights).

Alternatively, the following factors are considered positive indicators that the profits interests arrangement is more akin to a profit-sharing or deferred compensation arrangement accounted for in accordance with ASC Subtopic 710-10:

- (1) After fulfilling any stated vesting conditions, the rights to share in distributions are tied to continued employment. Mechanisms that are activated on termination of employment that could be embedded in the arrangement and would indicate a profit sharing or deferred compensation arrangement include:
 - (a) Automatic termination of any rights and/or return of units for no or nominal consideration.
 - (b) A repurchase feature at the option of either the entity or the employee (put/call) based on a formula that is not representative of a valuation technique that would approximate the fair value of the entity, or
 - (c) A call option (option is with the entity) that is in substance a forfeiture provision (see Paragraph 3.038).

The entity's right to repurchase the profits interest at fair value is not considered to be an indicator of a profit-sharing or deferred compensation plan because the employee is exposed to the ownership-type risks of changes in the value of the entity.

- (2) There are creditor-like features embedded in the profits interest such as a fixed redemption date or a specified return.

- (3) Management's intent is to provide a performance bonus by allowing the employee to share in profits and distributions of the entity during employment.
- (4) The profits interest plan is used as an alternative to a cash bonus to obtain preferential tax treatment.
- (5) The profits interest plan requires little or no initial investment. The lack of initial investment is a common attribute of many types of profits interest plans and other types of stock compensation arrangements. As a result, this factor is considered to be of lesser importance than other factors in concluding on the overall substance of the plan.

Q&A 1.30: Award of Profits Interests – Part I

Background

An LLC grants Class C units to employees with a three year service condition. Upon vesting, the terms of the Class C units provide for a cash payment to the employees equal to 5% of the increase in the book value of the LLC. The employees are not required to make a capital contribution to receive the Class C units. When an employee leaves the LLC (whether for voluntary termination, death, disability, or retirement), the Class C unit is forfeited and it becomes available to be distributed to other employees.

Q. Is the Class C unit a share-based payment?

A. No. This Class C unit does not represent an equity interest in the LLC because the employees do not have an investment at risk and the arrangement does not provide the employee with rights associated with having an ownership interest in the entity. After fulfilling any stated vesting conditions, the rights to share in distributions are tied to continued employment. The employee does not retain his or her rights under the arrangement upon termination of service. The award is always forfeited when an employee leaves, regardless of how long the employee has been employed with the LLC.

As a consequence, this award is treated as a profit-sharing arrangement, under which the employees have the right to receive a cash bonus in an amount equal to a specified percentage of the LLC's profits for the year. Therefore, the LLC should account for the awards as a profit-sharing arrangement and should recognize compensation cost based on the amount to which the employees are entitled each period.

Q&A 1.31: Award of Profits Interests – Part II

Background

An employee is granted a Class B profits interest award in its LLC employer. The membership interests vest ratably over a four-year period. If the employee terminates employment, the unvested membership interests will be forfeited for no consideration. The employer has a call option to repurchase vested units at fair value. In addition, the

terms of the repurchase feature provide the LLC the ability to delay repurchase until the employee has been exposed to risks and rewards of ownership for a reasonable period of time.

The LLC's organizing documents describe a waterfall as to how the fair value of the entity will be allocated to the different classes of equity as follows:

- a. Return of capital invested to the Class A units;
- b. Compounded rate of return at 12% to the Class A units;
- c. Residual amount shared proportionately between the Class A units and the Class B profits interests.

Q. Is this unit a share-based payment?

A. Yes. This instrument represents an equity interest in the LLC because the employee has an interest in the net assets of the entity at grant date. Specifically, the arrangement provides the employee with rights associated with having membership interest in the LLC. Employees have rights to participate in the residual net assets of the entity upon dissolution or liquidation proportionate to Class A profits interests. In addition, subject to vesting conditions, the employee retains his or her vested membership interest under the arrangement upon termination of service, subject to repurchase at fair value by the employer.

Therefore, the LLC should account for the awards as a share-based payment and should recognize compensation cost over the requisite service period.

Q&A 1.32: Award of Profits Interests – Part III

An LLC issues profits interest units that vest ratably over a three-year service period. They also vest in full on the occurrence of a Fundamental Change, which is defined as (a) a sale or merger, (b) acquisition of 50% or more of the voting rights by an unaffiliated party, or (c) dissolution or liquidation of the entity.

The Limited Liability Agreement specifies that cash distributions will be made first to members. The declaration and payment of distributions to members and award holders is solely within the discretion of the managing member. Once a pre-determined rate of return has been met for the members, excess earnings may be distributed to profits interests unit holders.

All profits interests units that have not yet vested will automatically be forfeited for no consideration if an employee is terminated for any reason.

The LLC agreement also states that in order to be entitled to distributions on the profits interest when paid, the award must be *vested* at the time the distribution is paid and the employee must remain employed. The LLC agreement also provides that any award,

whether vested or unvested is forfeited for no consideration, once the employer/employee relationship ceases.

However, if the employee remains employed at the date of a Fundamental Change, the profits interest will participate in the fair value of the entity pursuant to a waterfall stated in the LLC agreement.

In this situation, the awards would be considered to comprise two awards. Part of the award is an in-substance profit-sharing arrangement to be accounted for similar to discretionary cash bonus arrangements under ASC Subtopic 710-10, because the employees are not entitled to retain their rights if they cease to provide services before a Fundamental Change occurs. Even though the plan uses the term *vested* upon completion of the service condition, employees are required to continue to provide service beyond that date to continue to participate in distributions. Upon termination, employees forfeit all rights to future distributions and receive no consideration. Therefore this part of the award is not a share-based payment in the scope of Topic 718.

Compensation cost would not be recognized until it is probable that a distribution will occur. Because a holder must remain employed to continue to share in future distributions, a liability should only be recorded once it is probable that a distribution will be paid. Compensation cost to be recorded is the amount of the distributions paid to the holders.

The second part of the award contains the rights to a residual equity interest in the entity and is in the scope of ASC Topic 718. The vesting condition for this award is the occurrence of a Fundamental Change while the employee remains employed. This is a performance condition that is not probable of occurrence. Compensation cost would be recorded for those employees still working when a Fundamental Change becomes probable. The measurement of compensation cost for this part of the award would depend on whether it is equity or liability classified. If it is equity classified, the LLC would determine the grant date fair value of the award. When measuring the fair value, a reduction for the estimated dividends, if any, to be paid on the first part of the award would be appropriate to avoid double counting for the impact of the dividends. If the award is liability classified, the compensation cost would be measured at the amount of consideration paid to settle the award (which may be lower than the grant-date fair value).

1.068 As with other equity-based compensation, profits interests that represent share-based payment awards are valued at the grant date when recognizing compensation cost and are evaluated to determine whether equity or liability classification is appropriate. While the profits interest holder often does not have immediate liquidity (e.g., amounts are paid to the interest holder only on the occurrence of a liquidity event), the award has value to the holder due to the *upside* potential. In determining the fair value of profits interests, it is inappropriate to assume immediate liquidation of the profits interests. Instead, the valuation should be based on future cash flows that profits interest holders will be entitled to under the specified terms for cash distributions. This is similar to the valuation of

common stock in a closely held entity when preferred stockholders have distribution preferences and common shareholders only share in appreciation or cash flows beyond a *hurdle* amount. See Paragraph 2.161, “Valuation Techniques to Establish Enterprise Value” for additional discussion on this concept.

Section 2 - Measurement of Awards

Detailed Contents

Fair Value Measurement Objective

Measurement Date – Fair Value at Grant Date

Valuing Share Options

Sources of Share Option Value

Intrinsic Value or Minimum Value Method Does Not Measure Fair Value

Q&A 2.1: Volatility for Wholly Owned Subsidiary of a Public Company

Share Option Valuation Assumptions

Selecting the Assumptions

Historic Experience versus Future Expectations

Q&A 2.2: Estimating Expected Term Using SAB 107's Simplified Method for Awards with Graded Vesting

Share Price

Spring-loaded awards

Expected Volatility

Q&A 2.5: Calculating Volatility

Q&A 2.6: Calculating Volatility for a Newly Public Entity

Q&A 2.7: Reconciling Differing Estimates of Historical and Implied Volatility

Example 2.1: Weighting Volatility – Part I

Example 2.2: Weighting Volatility – Part II

Example 2.3: Weighting Volatility – Part III

Example 2.4: Weighting Volatility – Part IV

Q&A 2.8: Calculating Fair Value of a *Formula Based* Share Award of a Nonpublic Company

Expected Dividends

Expected Risk-Free Rate

Expected Share Option Term

Q&A 2.9: Valuation Assumptions When Share Options Are Exercisable Prior to Vesting

Example 2.5: Expected Term Calculation

Dilution

Credit Risk

Vesting Conditions

Q&A 2.10: Valuing a Share Option Award with a Performance Condition that may be Met After an Employee's Requisite Service Period

Performance Conditions Affecting Exercise Price

Example 2.6: Performance Condition Affecting Exercise Price

Market Conditions

Example 2.7: Determining Fair Value for Share Options with a Market Condition Performance and Service Conditions That Affect Factors Other Than Vesting

Example 2.8: Employee Awards Where Performance Condition Affects Factors Other Than Vesting

Reload Features

Clawback Features

Example 2.9: Accounting for a Clawback Feature

Example 2.10: Accounting for a Clawback Feature When the Value of Shares or Share Options Clawed Back Is Below the Compensation Cost

Valuing Separate Tranches of a Graded Award

Q&A 2.11: Graded Vesting

Inability to Value Complex Share Options

Acceptable Option Pricing Models

Black-Scholes-Merton Model

Lattice Model

Applying a Lattice Model

Suboptimal Exercise Factor

Postvesting Departure Rate

Building a Share-Price Tree

Valuing the Share Options

Expected Term

Relationship of Lattice Model Results to Black-Scholes-Merton Model Results

Changing to a Lattice Model

Q&A 2.12: Changing to a Lattice Model

Illustration of a Lattice Model

Example 2.11: A Lattice Model Approach

Use of Monte Carlo Simulation

Valuing Shares

Valuing Nonvested Shares

Treatment of Dividends Payable on Shares during the Vesting Period

Q&A 2.13: Valuation of Nonvested Shares Depending on Whether the Holder Is Entitled to Dividends in the Vesting Period

Valuing Restricted Shares

Illiquidity Discounts

Protective Put Models

Asian-Style Put Options

Finnerty Protective Put Method

Hedging Transaction without Upside

Forward Sale

Collar

In-the-Money Put Option

Example 2.12: Forward Sale

Example 2.13: Tight Collar

Example 2.14: In-the-Money Put Option

Valuing Private Entity Shares

Q&A 2.14: Valuation Impact of Secondary Market Transactions

Practical Expedient for Valuing Private Entity Shares

Other Measurement Issues

Valuing Employee Share Purchase Plans with Look-Back Share Options

Example 2.15: Valuing a Look-Back Share Option

Example 2.16: Valuing a Type B Look-Back Share Option

Transition from Nonpublic to Public Entity Status

2.000 This section discusses valuation issues related to share-based payments. It includes a description of the issues that may arise in the valuation of share options and share-based awards for financial reporting purposes, as well as guidance on matters related to measurement date, vesting conditions, and valuing shares issued as compensation in privately held entities.

FAIR VALUE MEASUREMENT OBJECTIVE

2.001 Entities are required to account at fair value for transactions in which equity or equity-based instruments are issued in exchange for goods or services with either employees or nonemployees.¹ We believe that the fair-value measurement principles in ASC Topic 820 (see KPMG Handbook, Fair value measurement) apply to valuing equity or equity-based instruments within the scope of ASC Topic 718, except where ASC Topic 718 specifically provides other guidance. While equity-classified awards issued by nonpublic entities are subject to the same general fair value measurement principle, if it is not possible for a nonpublic entity to reasonably estimate the fair value of its awards because it is not practicable to make a reasonable estimate of the expected volatility of its share price, then the nonpublic entity is required to use an alternative measurement method that utilizes the historic volatility of an appropriate index. The resulting value is referred to as calculated value.² It should be noted that calculated value is only appropriate when a nonpublic entity is unable to reasonably estimate its expected volatility. Provisions in ASC Topic 718, *Compensation—Stock Compensation*, that apply to accounting for share options and related instruments at fair value also apply to calculated value. ASC paragraphs 718-10-30-2 and 30-20

2.001a Nonpublic entities may elect a practical expedient for valuing equity-classified awards, whether for a nonvested stock award, or as an input into an option-pricing model. The practical expedient does not change the measurement objective of ASC Topic 718; all entities must use a valuation model that meets the measurement objective of ASC Topic 718 to determine the fair value of their equity-classified awards. Instead, the practical expedient allows flexibility in determining the nonvested share price, or option-based award share price input to an option pricing model, by using a ‘reasonable application of a reasonable valuation method’. See Paragraph 2.161a.

2.002 Nonpublic entities may elect to account for liability-classified share-based payment awards using the fair value method or the intrinsic value method. Selecting a measurement method is an accounting policy choice and is consistently applied to all liability-classified share-based payment awards. Regardless of the policy elected, liability-classified awards are remeasured at each reporting date until the award is settled. Nonpublic entities that have elected to account for liability-classified share-based payment awards using the fair value method may not subsequently change their policy to use the intrinsic value method because the intrinsic value method is not preferable under ASC Topic 718 (see discussion on preferability in KPMG Handbook, Accounting changes and error corrections, Section 3.3.20).

A nonpublic entity's policy election to value liability-classified awards at intrinsic value would not apply to share-based consideration payable to customers, as these awards are required to be measured at fair value.

For an illustrative example of liability-classified awards granted by a nonpublic entity that elects the intrinsic value method, see ASC paragraphs 718-30-55-12 through 55-20.

Measurement Date – Fair Value at Grant Date

2.003 The measurement objective is to estimate, at the grant date, the fair value of the award to which grantees become entitled when they have delivered the goods or rendered services and satisfied other conditions necessary to earn the right to benefit from the award.³ However, the estimate of fair value should be based on share price and other factors as of the grant date. Consequently, the measurement date of an award is the grant date. Accordingly, this fair value measure is referred to as *grant-date fair value*. ASC paragraph 718-10-30-6

2.004 For equity-classified awards, changes in the share price or other pertinent variables, such as volatility or the risk-free rate, subsequent to the grant date would not cause the fair value estimate to be remeasured. However, liability-classified awards are required to be remeasured at each reporting date until settlement, based on assumptions that marketplace participants would use at each measurement date (i.e., a preparer would need to update the assumptions in its option pricing model, such as share price, expected volatility, risk-free rates, etc.). Section 3, *Classification of Awards as Either Liabilities or Equity*, discusses the classification of an award as liability or equity. ASC paragraph 718-10-55-4

2.005 ASC paragraph 718-10-S99-1 explicitly acknowledges that the fair value of a share option at the grant date is unlikely to correspond to the amount that is ultimately realized by the option holder on exercise. Differences between the actual outcomes and the original estimates of fair value, either with respect to the values reported or the assumptions used in developing the fair-value estimates, do not necessarily indicate that the original estimate was incorrect or inappropriate when the valuation was performed.

2.006 ASC paragraph 718-10-55-27 provides that the assumptions incorporated into the fair value measurement for liability- and equity-classified awards should be determined in a consistent manner from period to period. Many share option plans specify how the entity should determine the exercise price of an award (i.e., “the exercise price should be equal to the closing price of the entities’ common stock on the date of grant”). When the plan indicates the method for determining the exercise price, the plan’s provisions should be followed. However, if the plan does not indicate a method for determining the exercise price, an entity should apply a consistent method of determining the time for which the quoted market price is to be used as the exercise price for share option awards. Furthermore, as provided by the SEC’s disclosure rules on executive compensation included in Item 402(d)(2)(vii) of Regulation S-K, registrants are required to describe the methodology for determining the exercise price whenever the exercise price is lower than the closing price on the date of grant.

VALUING SHARE OPTIONS

2.007 When observable market prices of identical or similar equity-based instruments in active markets are not available, the fair value of a share option should be estimated using an option-based pricing model.⁴ Suitable models should:

- a. Be applied in a manner consistent with the fair value measurement objective and other requirements of ASC Topic 718;
- b. Be based on established principles of financial economic theory and generally accepted by experts in that field; and
- c. Include any and all substantive characteristics of the instrument (except those explicitly excluded by ASC Topic 718, such as reload features). ASC paragraph 718-10-55-11

2.008 Both the model, as well as the assumptions used to populate the model, should be consistent with those a marketplace participant would use to value the instrument.⁵

2.009 ASC paragraph 718-10-S99-1 indicates that an entity is not required to retain an external valuation specialist to perform a valuation of its share-based payment arrangements. However, the person performing the valuation will need to have the requisite expertise to evaluate the appropriateness of the inputs as well as the model. The level of expertise needed will depend on the complexity of the award and the valuation technique employed.

Sources of Share Option Value

2.010 The fair value of a share option is generally regarded as deriving from two sources: (1) intrinsic value, which is the excess of the share price over the share option exercise price, and (2) time value. Furthermore, the time value of a share option has two components. One component of time value represents the benefit to the share option holder of not having to pay for the underlying share until the exercise date, while the other element of time value is volatility. Greater volatility of the underlying share price increases the value of a share option because the more volatile a share price movement is, the greater the possible increases in the share price and, thereby, the share option's value. An option pricing model should capture each of these elements of share option value.

Intrinsic Value or Minimum Value Method Does Not Measure Fair Value

2.011 The intrinsic value method previously used in accordance with APB Opinion No. 25, *Accounting for Stock Issued to Employees*, ignores the time value of a share option.⁶ The minimum value method previously permitted for nonpublic entities under FASB Statement No. 123, *Accounting for Stock-Based Compensation*, does not consider the volatility-related value of a share option and, therefore, does not reflect fair value. Neither intrinsic value nor minimum value would be used by a marketplace participant to

estimate the fair value of a share option and, as a result, neither is an acceptable method of calculating fair value. Statement 123(R), par. B57

Q&A 2.1: Volatility for Wholly Owned Subsidiary of a Public Company

Q. Is a wholly owned subsidiary of a public company required to consider volatility when calculating the fair value of its share options?

A. Whether a company is public or nonpublic, it is required to consider volatility when estimating the fair value of awards. The minimum value method is not permitted.

Moreover, although the subsidiary may not have public shares outstanding, it would be considered a public company because it is a subsidiary of a public company. As a result, as a public company, it would not be permitted to elect to value liability-classified, share-based payment arrangements at intrinsic value, nor would it be able to use calculated value.

If the subsidiary lacks sufficient historical information to calculate volatility of its own shares, it may estimate volatility based on the average volatility of peer companies for an appropriate period of time. An entity will need to evaluate its specific facts and circumstances to determine whether another entity (including its parent) is *similar*, based on factors such as industry, stage of life cycle, relative size, and financial leverage. (See Q&A 2.6 and discussion beginning at Paragraph 2.032).

SHARE OPTION VALUATION ASSUMPTIONS

2.012 Option pricing models should consider, at a minimum, the following assumptions or variables:

- a. Current price of the underlying share;
- b. Exercise price of the share option;
- c. Expected volatility of the return on the underlying share during the expected term of the share option;
- d. Expected dividend yield on the underlying share during the expected term of the share option;
- e. Risk-free interest rate during the expected term of the share option; and
- f. Expected term of the share option, taking into account both the contractual term of the share option and the effects of grantees' expected exercise and postvesting termination behavior. ASC paragraph 718-10-55-21.

2.013 ASC Topic 718 uses the phrase *expected term* rather than *expected life*. Expected term implies consideration of the contractual term of the share option and the effect of employee exercise patterns that result in a share option term that is shorter than its

contractual life. The valuation of a share option should reflect the fact that employees often exercise share options prior to expiration. Consequently, the expected term is normally shorter than the contractual life of the share option. ASC paragraph 718-10-55-29 However, for nonemployee awards, on an award-by-award basis, an entity may elect to use the contractual term as the expected term when estimating the fair value, as the nonemployee exercise patterns are not always known or determinable. If an entity does use the expected term for nonemployee awards, similar considerations for the simplified method, such as the inability to sell or hedge a nonemployee award, apply. See Section 2.062 and Paragraph 2.025 for use of the simplified method.

2.014 The directional relationship between share option value and these key assumptions is:

| Input Assumptions | Effect on Share Option Value from an Increase in Input |
|--------------------------|---|
| Market price of share | Higher |
| Exercise price | Lower |
| Expected term | Higher |
| Expected volatility | Higher |
| Dividends | Lower |
| Risk-free rate | Higher |

2.015 The relationship between share option value and expected term and volatility is illustrated in the following graph, which indicates that for a given level of volatility, the share option value increases as the term increases. Also, for a given term, share option value increases as the level of volatility increases. It is important to note that the rate of increase is not linear. For example, a four-year share option does not have a value that is twice as high as the value of a two-year share option. An option's sensitivity to these and the other assumptions discussed later in this section means that significant effort should be focused on developing and supporting appropriate assumptions. Furthermore, estimating the fair value of an award using assumptions that average different behaviors can misstate the value of an award. Accordingly, individual award recipients should be grouped into relatively homogeneous groups that can be expected to have similar exercise and postvesting termination behaviors. ASC paragraph 718-10-S99-1 suggests that as few as one or two groupings may be sufficient to make reasonable fair value estimates in certain circumstances. ASC paragraph 718-10-55-34

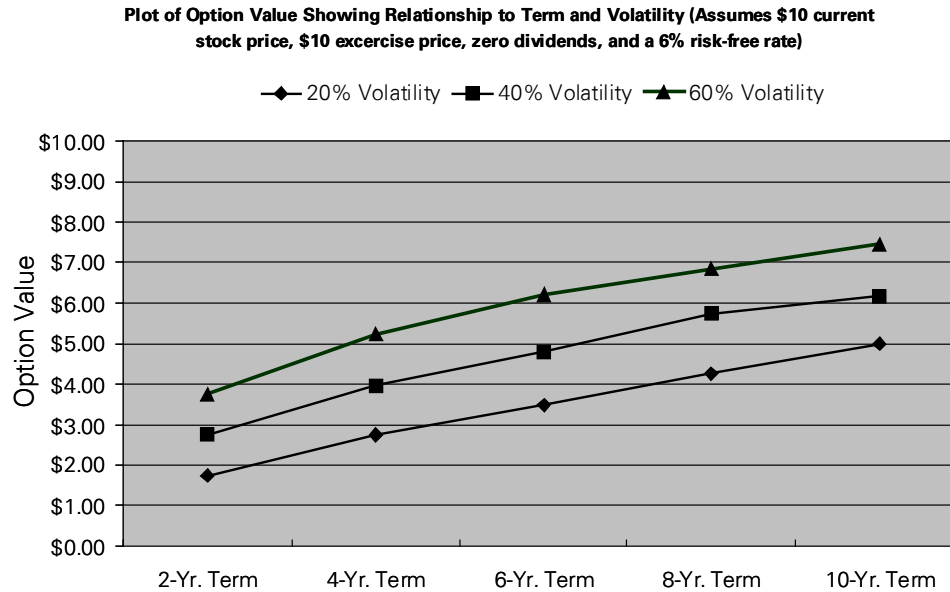

Selecting the Assumptions

2.016 Applying the option pricing model should be based on management’s supportable expectations about the model’s assumptions, including the expected term of the share option, future dividends on the shares during the expected term of the share option, the risk-free rate, and share price volatility during the term of the share option. Using unsupported rules of thumb as assumptions is not appropriate. The volatility, dividend yield, and risk-free rate assumptions should represent reasonable expectations commensurate with the expected term of the share option. For example, in the United States the risk-free rate is the rate for zero-coupon U.S. Treasury instruments; therefore, the rate of a zero-coupon U.S. Treasury instrument with a maturity date that approximates the expected term of the share option would be used as an input in the option pricing model used to value the option.

2.017 While there may be a narrow range of reasonable expectations for the risk-free rate, there is likely to be a wider range of reasonable expectations about factors such as expected volatility and expected term. If no amount within the range is more likely than any other, a probability-weighted average of the range (its expected value) should be used. It is not permissible to select the assumption in the range that minimizes the share option’s value when there is a range of possible assumptions, because that would not be consistent with marketplace participants’ assumptions in valuing the instrument. ASC paragraph 718-10-55-23

2.018 ASC paragraph 718-10-S99-1 notes that the process used to gather and review assumptions should be applied consistently from period to period. A change in either the method of determining appropriate assumptions used in a valuation technique or a change in the valuation technique or model is a change in accounting estimate, not a change in accounting principle, for purposes of applying ASC Subtopic 250-10, *Accounting Changes and Error Corrections - Overall*, and should be applied prospectively to newly

granted awards and subsequent revaluations of liability-classified awards. See also KPMG Handbook, Accounting changes and error corrections, Question 3.2.50 and Chapter 3.

Historic Experience versus Future Expectations

2.019 Statement 123 stated that unadjusted historical volatility experience might be a poor predictor of future experience, indicating that the appropriateness of utilizing historical volatility experience should be assessed and that alternative measures may need to be considered and weighted. Statement 123 included an example of a company that disposed of one of two lines of business, such that historical volatility and perhaps share option terms would not be representative of future expectations. Nonetheless, many entities relied on historical experience because of the difficulty of estimating and supporting alternative assumptions. Statement 123, par. 276

2.020 Similarly, ASC Topic 718 provides that historical experience is a starting point for developing assumptions about future expectations. However, it also states that entities should consider how the future might reasonably differ from the past. ASC Topic 718 specifically states that if an entity's stock price experienced a high degree of volatility for a period of time because of a general market decline, an entity may place less weight on historical volatility for that period because of mean-reversion tendency of stock price volatility (i.e., volatility will tend to revert to a long-term average after periods of greater than or less than long-term average volatility). To support such a lower weight being assigned to its historical volatility, an entity should evaluate changes in its share price historical volatility over time to identify trends (e.g., whether the stock price appears to be becoming more or less volatile over time).⁷ This analysis may indicate that the best estimate of expected future volatility over the option's expected term may not be its historical volatility over the most recent historical period commensurate with the expected term. This may be further supported by the implied volatility of traded options on the entity's stock or the implied volatility of convertible instruments with robust trading volume for which the conversion feature is a significant factor in determining fair value of the instrument. This may be the case when the embedded conversion feature ranges from being slightly out-of-the-money to being in-the-money. For convertible instruments that are deep-out-of-the-money, the conversion feature is less likely to be a significant factor in determining fair value of the instrument and, accordingly, the implied volatility of the embedded option would be less relevant to the analysis. For newly public entities, an analysis of peer companies may indicate that volatility declines for comparable companies that have been public longer. ASC paragraphs 718-10-55-24 and 55-37

2.021 Related to expected term estimates, entities may develop a more rigorous process, including stratifying grantees based on demographic and other factors, and data mining and analysis of the grantees' prior exercise behavior to identify suboptimal exercise factors (i.e., at what multiples of the exercise price were options exercised), postvesting termination rates, other postvesting exercise behaviors (e.g., exercise of share options *clusters* around events such as the share option going in-the-money after having been *out-of-the-money* for a period of time), and the actual lives of exercised and unexercised share options.

2.022 The predictive significance of such relationships should be carefully assessed and supported for each identified stratum. An entity may find limited correlation between historical exercise behavior and identifiable events or stock price patterns. Entities that award broad-based grants often evaluate expected term for different homogeneous groups (e.g., calculate different exercise and postvesting employment termination behaviors for different groups to identify correlated behavior). For example, the historical experience of an employer that grants share options broadly to all levels of employees might indicate that hourly employees tend to exercise for a smaller percentage gain than do salaried employees. ASC paragraph 718-10-55-34

2.023 The number of groups that an entity identifies will depend on a variety of factors, including whether grants span geographical as well as functional boundaries within the entity and whether greater stratification results in more highly correlated exercise and postvesting employment termination behaviors within the groups. However, ASC paragraph 718-10-S99-1 states that as few as one or two groupings may be sufficient for grants of similar awards.

2.024 ASC Topic 718 also states that expected term might be estimated from industry averages or academic research, if sufficient entity-specific information is not available. However, we expect that an entity would initially research and analyze its own historical experience before reaching a conclusion that historical experience would not be representative of expected future term. Additionally, entities may find it difficult to obtain reliable industry averages for employee or nonemployee exercise behavior. While publicly available data about grantee exercise patterns is currently limited, ASC paragraph 718-10-S99-1 states that the SEC staff anticipates that usable industry expected term information will become more widely available in the future from sources such as actuaries and valuation professionals. Entities should consult with valuation professionals about the availability of such data. ASC paragraph 718-10-55-32

2.025 Paragraphs 2.025 – 2.030 relate to an entity using a simplified method in certain circumstances for employee share-based payment awards, and those circumstances also apply when using a simplified method for nonemployee awards. When an entity has limited employee share option exercises or when the available data does not demonstrate consistent early exercise behavior, ASC paragraph 718-10-S99-1 allows the entity to use a *simplified method* in certain circumstances. The simplified method makes the assumption that the employee will exercise share options evenly over the period when the share options are vested and ending on the date when the share options would expire. ASC paragraph 718-10-S99-1 limits use of the simplified method for public companies to *plain vanilla* share options, which are defined as the share options having the following characteristics (see Paragraph 2.030a for a similar simplified method practical expedient for nonpublic entities):

- Share options are granted at-the-money;
- Exercisability is conditional only on performing service through the vesting date;

- If an employee terminates service prior to vesting, the employee forfeits the share options;
- If an employee terminates service after vesting, the employee has a limited period of time (typically 30 - 90 days) to exercise the share options; and
- Share options are nontransferable and nonhedgeable.

2.026 ASC paragraph 718-10-S99-1 provides additional guidance on the situations where the SEC staff believes it may be appropriate to use the simplified method:

- The entity does not have sufficient historical exercise data because its equity shares have been publicly traded for only a limited period of time (i.e., it is a newly public company).
- Significant changes to the contractual terms of the entity's share option grants or the types of employees that receive share option grants raise questions as to whether the historical exercise data continue to provide a reasonable basis for estimating the expected term for one or more strata of the current share option grants.
- Significant structural changes in the entity's business (e.g., spin-off of a significant portion of its business) or the expectation of such changes raise questions as to whether its historical exercise data continue to provide a reasonable basis for estimating the expected term for the current share option grants.

2.027 Entities that have sufficient historical exercise data for some of their share option grants but not others should use the simplified method only for the grants for which the historical exercise data does not provide a sufficient basis for estimating the expected term. For example, an entity might have made significant changes to broad-based employee grants but not to executive grants. The SEC staff also noted that it will not object to the use of the simplified method for grants made before the date that a company's equity shares are publicly traded.

2.028 This *simplified method* averages an award's weighted average vesting period and its contractual term. (ASC paragraph 718-10-S99-1) Under ASC paragraph 718-10-S99-1, the SEC staff will continue to accept the simplified method for estimating the expected term of a plain vanilla share option grant under the specified conditions described above.

2.029 In addition, entities that use the simplified method to estimate the expected term of their share options should disclose their use of the method, why they are unable to rely on their historical exercise data, the types of grants to which the simplified method was applied, and the periods for which the method was used if it was not used in all periods presented.

Q&A 2.2: Estimating Expected Term Using SAB 107's Simplified Method for Awards with Graded Vesting

Q. ABC Corp. issues *plain vanilla* share options to employees with a four-year vesting schedule, in which 25% of the share options cliff vest at the end of each of the four years. The share options have a 10-year contractual term. ABC has very limited employee exercise experience and it is unable to discern company-specific data on which to estimate the expected term for the share options. How would ABC calculate the expected term of its awards using the simplified method?

A. The simplified method assumes that share options will be exercised evenly over the period from vesting until the awards expire. Because this share option has graded vesting, the assumed period for each tranche would be computed separately and then averaged together to determine the expected term for the award, as follows:

| Tranche & Vesting Period | Average Term | Weighting | Weighted Average |
|--------------------------|--------------|-----------|------------------|
| 1 | 5.5 years | 25% | 1.375 years |
| 2 | 6.0 years | 25% | 1.500 years |
| 3 | 6.5 years | 25% | 1.625 years |
| 4 | 7.0 years | 25% | 1.750 years |
| | | | 6.25 years |

Another way to think about the simplified method is that it averages the weighted-average vesting period and the contractual term, as follows:

| Vesting Period | Weighting | Weighted Vesting |
|--|-----------|------------------|
| 1 Year | 25% | 0.25 Years |
| 2 Years | 25% | 0.50 Years |
| 3 Years | 25% | 0.75 Years |
| 4 Years | 25% | 1.00 Years |
| Weighted-average vesting period | | 2.50 Years |
| Average of vesting period and contractual term (2.5 years + 10 Years)/2 | | 6.25 Years |

2.030 Even though an entity may have developed its own historical experience of employee exercise behavior or one of the other factors used as an input in the option pricing model, it will need to monitor those historical results for changes. For example, if the entity changes the nature of its share option plans, employee exercise behavior may be expected to change. As a consequence, historical patterns of employee exercise behavior may no longer be expected to occur in the future.

2.030a Practical Expedient for Expected Term – Nonpublic Entities. Nonpublic entities may estimate the expected term for awards using the simplified method, but only if the awards have the following characteristics:

- The share option or similar award is granted at-the-money;
- The grantee has only a limited time to exercise the award (typically 30 – 90 days) if the grantee no longer provides goods or terminates service after vesting;
- The grantee cannot sell or hedge the award (the grantee can only exercise the award); and
- The award does not include a market condition.

A nonpublic entity that elects to apply the practical expedient for its employee awards may separately elect to use the contractual term as the expected term when estimating the fair value of a nonemployee award (on an award-by-award basis). However, if a nonpublic entity does not elect to use the contractual term as the expected term, and it elects the accounting policy to apply the practice expedient in Paragraph 2.030a, the nonpublic entity must apply the practical expedient for all nonemployee awards that have all of those characteristics, in the same manner as for employee awards. ASC paragraph 718-10-30-20B

If a nonpublic entity elects the practical expedient, it would make an entity-wide accounting policy (for either its employee awards or employee and nonemployee awards) and apply the practical expedient to all awards having the above characteristics. This practical expedient is similar to the *simplified method* discussed above starting in Paragraph 2.025, in that it makes the assumption that the grantee will exercise share options evenly over the period when the share options are vested and ending on the date when the share options would expire.

Under this practical expedient, if vesting is dependent on:

- *A service condition*, an entity would estimate the expected term as the midpoint between the employee's requisite service period or the nonemployee's vesting period and the contractual term of the award.
- *Satisfying a performance condition that is probable of being achieved*, an entity would estimate the expected term as the midpoint between the employee's requisite service period or nonemployee's vesting period and the contractual term.
- *Satisfying a performance condition that is not probable of being achieved*, the entity would estimate the expected term as the contractual term, if the service period is implied. That is, the requisite service period or the nonemployee's vesting period is not explicitly stated but inferred based on the achievement of the performance condition at some undetermined point in the future (see Paragraph 4.053 for discussion on requisite service period, including implied service periods); or the midpoint between the employee's requisite service period or nonemployee's vesting period and the contractual term, if the service period is explicitly stated in the award.

Estimating the Expected Term for Awards Using the Practical Expedient

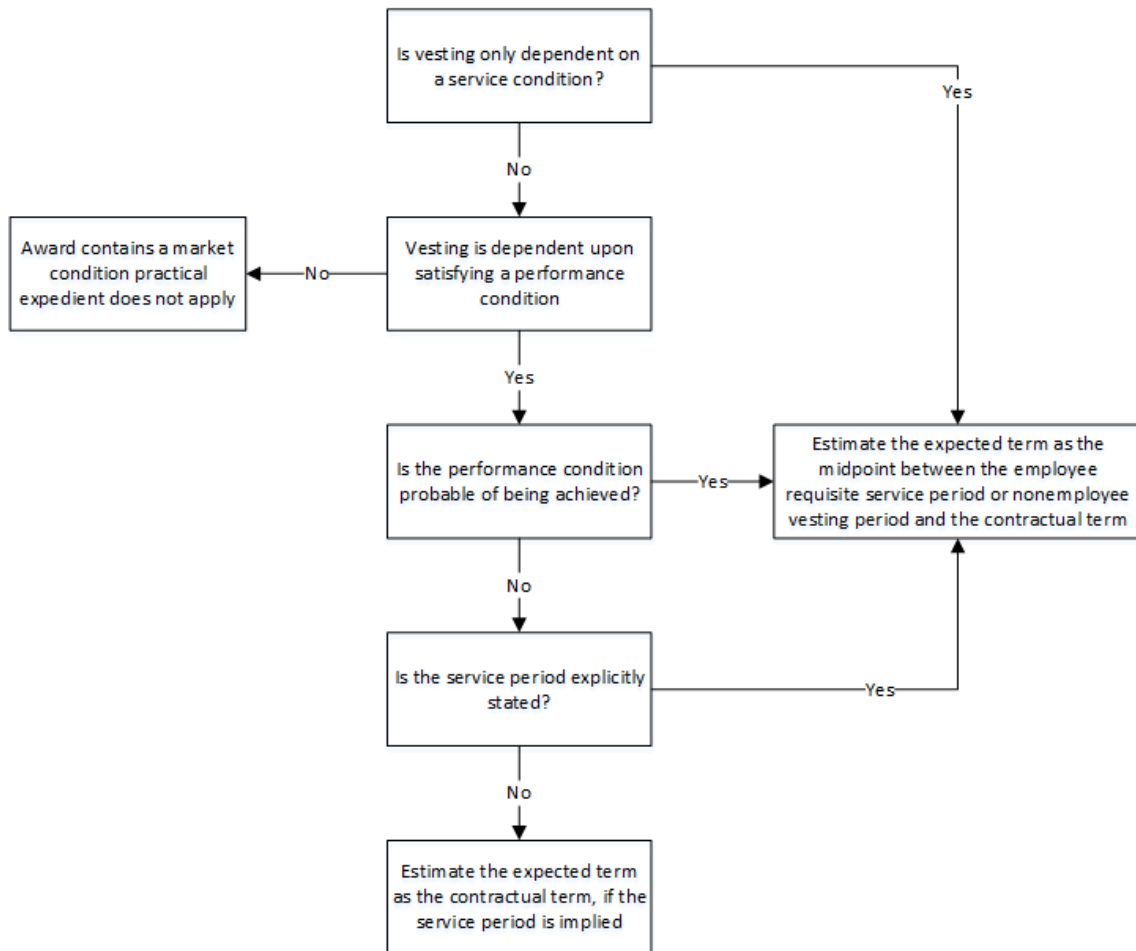

Entities can apply the practical expedient to all awards that are measured at fair value. This practical expedient cannot be applied to awards with a market condition because awards with a market condition generally cannot be valued using an option pricing model that uses a single estimate for the expected term (e.g., the Black-Scholes option pricing model). The practical expedient can, however, be applied to awards with repurchase features, as a repurchase feature is not a share option valuation assumption.

For liability-classified awards, a nonpublic entity would update the estimate of the expected term each period until settlement. The updated estimate would reflect any change in the assessment of whether achievement of a performance condition is probable.

Share Price

2.031 The share price input in an option pricing model is normally based on the share price on the measurement date. In general, we believe that the closing price is the most representative indication of fair value, as it reflects all of the information that is available for that day. We believe the intra-day high trade or the low trade of the day should not be

used as the quoted market price, nor should an entity use an average of the quoted market prices over several days. However, discounts to the price that will be used as an input may be appropriate for postvesting security-specific restrictions on the shares into which the share options are exercised, if those restrictions will remain in effect after the share options are exercised. While a discount to the share price may be appropriate, an additional discount applied to the value of the share option to reflect its nontransferability is inappropriate. The nontransferability of the share option is considered through the impact of early exercise behaviors on the expected term of the share option and is not considered by applying a discount to the value calculated by the option pricing model. See the discussion of the valuation of restricted shares and the appropriate discounts to share prices beginning at Paragraph 2.138.

SPRING-LOADED AWARDS

2.031a Adjustments to share price may be required to reflect material nonpublic information known to the entity but unavailable to marketplace participants at the time the market price is observed. Significant judgment is required in determining whether an adjustment is necessary, and if so, the magnitude of the adjustment. The SEC staff acknowledges that entities generally possess nonpublic information when entering into share-based payment transactions. The SEC staff believes that an observable market price on the grant date is generally a reasonable and supportable estimate of the current price of the underlying share in a share-based payment transaction, for example, when estimating the grant-date fair value of a *routine* annual grant to employees that is *not* designed to be spring-loaded. SAB Topic 14.D.3

2.031b The SEC staff believes that entities should carefully consider whether an adjustment to the observable market price is required, for example, when share-based payment arrangements are entered into in contemplation of, or shortly before, a planned release of material nonpublic information, and such information is expected to result in a material increase in share price ('spring-loaded award'). The SEC staff believes that nonroutine spring-loaded grants merit particular scrutiny by those charged with compensation and financial reporting governance. Additionally, when an entity has a planned release of material nonpublic information within a short period of time after the measurement date of a share-based payment, the SEC staff believes a material increase in the market price of the entity's shares on release of such information indicates marketplace participants would have considered an adjustment to the observable market price on the measurement date to determine the current price of the underlying share. SAB Topic 14.D.3

Expected Volatility

2.032 Volatility is a measure of the amount that a share's price has fluctuated (historical volatility) or is expected to fluctuate (expected volatility) during a specified period. Volatility is expressed as a percentage. For example, a share with a volatility of 25% would mean that its annual rate of return would fall within a range of plus or minus 25 percentage points of its expected rate of return about two-thirds of the time. Therefore, if a share currently trades at \$100 with a volatility of 25% and an expected rate of return of

12%, after one year the share price should fall within the range of \$88 ($\$100 \times e^{(.12-.25)}$) to \$145 ($\$100 \times e^{(.12+.25)}$) approximately two-thirds of the time. Shares with high volatility provide share option holders with greater economic *upside* potential and, because the share option holder is not exposed to downside risk (beyond the option premium, which is usually zero cash outlay), result in higher share option fair values.

2.033 Because volatility is a measure of the share's price fluctuation, measures of volatility, whether historical or implied, are based on actual observed prices for the stock (for historical volatility) or the traded option (for implied volatility). Use of dealer quotations or average prices (e.g., the average stock price for a period) to compute volatility is not appropriate. Additionally, the SEC staff has indicated that the observed prices should be chosen from the same point at each measurement date (e.g., opening price, closing price) and should not be based on an average price, such as the daily average price, for the measurement period.

2.034 Historical Volatility. Estimates of expected future volatility should first consider historical volatility over the most recent period equal to the expected term of the share option. Thus, if the expected term of the share option is six years, historical volatility should be calculated for a six-year period preceding the share option grant. Also, the entity may calculate a six-year historical volatility measure over more than one recent six-year period to observe the trend of its historical volatility. Finally, because a lattice model applies early exercise parameters over the contractual term of a share option, the historical volatility over a period commensurate with the contractual term rather than the expected term should be considered when applying a lattice model.

Q&A 2.3 – 2.4 Not used.

Q&A 2.5: Calculating Volatility

Q. How should an enterprise calculate historical volatility using reported share prices?

A. Historical volatility is calculated as the standard deviation of the continuously compounded historical returns, computed from historical stock prices. Volatility may be calculated based on different time intervals (e.g., daily, weekly, or monthly).

This is shown below for a 19-week period (the period selected is for illustrative purposes only; as discussed in this section, the period used should generally be commensurate with the expected term of the share option).

| Period | Share Price End of Week | P_n/P_{n-1} | $\ln(P_n/P_{n-1})$ |
|--------|----------------------------|---------------|--------------------|
| Week 0 | \$ 50.00 | — | — |
| Week 1 | \$ 51.50 | 1.03000 | 0.02956 |
| Week 2 | \$ 52.00 | 1.00971 | 0.00966 |

| | | | |
|----------------------|----------|---------|-----------|
| Week 3 | \$ 51.00 | 0.98077 | (0.01942) |
| Week 4 | \$ 48.50 | 0.95098 | (0.05026) |
| Week 5 | \$ 46.50 | 0.95876 | (0.04211) |
| Week 6 | \$ 45.75 | 0.98387 | (0.01626) |
| Week 7 | \$ 50.50 | 1.10383 | 0.09878 |
| Week 8 | \$ 53.50 | 1.05941 | 0.05771 |
| Week 9 | \$ 51.75 | 0.96729 | (0.03326) |
| Week 10 | \$ 53.25 | 1.02899 | 0.02857 |
| Week 11 | \$ 54.50 | 1.02347 | 0.02320 |
| Week 12 | \$ 56.00 | 1.02752 | 0.02715 |
| Week 13 | \$ 53.50 | 0.95536 | (0.04567) |
| Week 14 | \$ 52.00 | 0.97196 | (0.02844) |
| Week 15 | \$ 55.00 | 1.05769 | 0.05609 |
| Week 16 | \$ 56.25 | 1.02273 | 0.02247 |
| Week 17 | \$ 58.00 | 1.03111 | 0.03064 |
| Week 18 | \$ 55.50 | 0.95690 | (0.04406) |
| Week 19 | \$ 56.00 | 1.00901 | 0.00897 |
| Weekly volatility | | | 4.2% |
| Annual volatility | | | 29.9% |

P_n is the price of the share on day n (in this example, the share price at the end of weeks 1 through 19), and P_{n-1} is the price on the period before n (in this example, the share price at the end of weeks 0 through 18).

\ln is the natural logarithmic function.

Weekly volatility is determined as the standard deviation of all the items in the $\ln(P_n/P_{n-1})$ column.

However, most option pricing models use annual share price volatility as an input into the model. Annual volatility is determined by multiplying the volatility estimate for a given period by the square root of the number of periods in a year:

$$0.041516 \times \sqrt{52}$$

If daily volatility is used, the volatility estimate is multiplied by the square root of the number of actual trading days during the year (e.g., 255).

2.035 Volatility may be calculated based on different time intervals (e.g., daily, weekly, or monthly). We would expect public entities to use more frequent price observations than nonpublic entities because more price data are available. The FASB has suggested

that a publicly traded entity would likely use daily price observations, while a nonpublic entity with shares that occasionally change hands at negotiated prices might use monthly price observations (a nonpublic entity would also be expected to consider peer company data). ASC paragraph 718-10-S99-1 states that use of weekly or monthly observations may be more appropriate for a public company with thinly traded shares because a wider bid/ask spread and lack of consistent trading may upward bias the volatility estimate. However, if the expected or contractual term, as applicable, of the share option is less than three years, the SEC staff believes that monthly price observations would not provide a sufficient amount of data on which to base historical volatility estimates.⁸ Entities should establish and consistently apply a policy related to the frequency of price observations when calculating historical volatility. We believe that a change in an entity's policy related to the frequency of price observations is a change in accounting estimate, not a change in accounting principle. ASC paragraphs 718-10-30-20 and 55-37(d)

2.036 An entity may find that there are periods when its stock price experiences much higher or lower volatility than during other periods. Generally, an entity is not permitted to *exclude* those periods of higher or lower volatility from its measure of historical volatility. ASC paragraph 718-10-S99-1 states that periods should be excluded from the measure of historical volatility only when there have been specific, discrete historical events that are not expected to recur. The SEC staff expects such situations to be rare.

2.037 Events such as mergers or acquisitions, changes in capital or corporate structure, or adverse press reports are events that may recur and, generally, would not be a basis for *excluding* a period when calculating historical volatility. Likewise, it is generally inappropriate to exclude periods surrounding events, such as an IPO, even when these events are not expected to recur because an IPO's impact on volatility is expected to be limited since, consistent with an efficient market, prices would respond quickly to the event itself. Therefore, if the markets are efficient, prices observed subsequent to the IPO would reflect events occurring after the IPO and would not be unduly affected by the IPO event itself. We believe an entity should not exclude specific events or circumstances from its measure of historical volatility unless those events or circumstances are nonrecurring, specific to the entity, and are within the control of the entity. Events or circumstances affecting the overall market, including those that are considered unlikely to recur, should not be excluded. Any such exclusions are expected to be rare.

2.038 ASC Topic 718 does, however, allow less weight to be placed on a period during which an entity's stock price volatility was unusually high or low because the theory of mean reversion states that volatility can be expected to return to its longer-term historical norms (see Paragraph 2.040). ASC paragraph 718-10-55-37(a)

2.039 However, historical share price volatility is only one of the factors that an entity should consider in estimating expected volatility. Entities should not use historical information for the input assumption of expected volatility without considering how future experience might reasonably be expected to differ from historical experience, e.g., because of the change in capital structure or announcement of a merger with a company that would change its business in the future. ASC paragraph 718-10-55-24

2.040 Other Factors to Consider. In estimating expected volatility, ASC Topic 718 indicates that the following other factors should be considered:

- Implied volatility determined from the market prices of traded options or other traded financial instruments of the entity, if any.** Implied volatility is the volatility implicit in the prices of an entity's currently traded options. Implied volatility is calculated by taking the prices of traded options along with assumptions for the other inputs in the option pricing model and solving for volatility. Implied volatility information may be available from financial information reporting services. Implied volatility is generally interpreted as the market's estimate of volatility over the term of the traded option. However, implied volatility estimates are often only available for relatively short time periods. For example, most traded options have terms of less than nine months, while employee share options have expected terms of four to seven years or longer. Although Long-Term Equity Appreciation Participation Securities (LEAPs) issued on an entity's shares may provide information on expected medium-term volatility, the maximum term on LEAPs is generally three years.⁹ As a result, LEAPs may provide evidence of expected medium-term rather than expected long-term volatility. Traded warrants, e.g., warrants previously issued with debt, may have long contractual terms from which long-term implied volatility may be estimated. Certain other instruments, such as convertible debt, have option-like characteristics. By pricing a similar nonconvertible debt instrument (taking into consideration current interest rates and credit quality), the entity may be able to estimate the value of the option feature embedded in the convertible debt instrument, which can then be used to estimate implied volatility over the remaining term of the convertible debt instrument. Because of the complexity of many underlying instruments, in particular because of the frequent inclusion of multiple embedded put and/or call features, it may not be practicable to derive an estimate of implied volatility from a convertible instrument. In using information implied from the prices of any traded financial instrument, an entity should assess whether the market in which the instrument trades is active. Using an implied volatility measure for a date shortly prior to or on the grant date can serve as a reasonable estimate of marketplace participant assumptions about implied volatility of the underlying stock on the grant date. This is sometimes referred to as spot implied volatility. However, using multiple measures of spot implied volatility over an extended period of time prior to the grant date (sometimes referred to as historical implied volatility) generally is not acceptable because it commingles the market's current expectations of volatility with expectations that existed at prior dates but are no longer reflective of current market expectations. ASC paragraph 718-10-S99-1 indicates that implied volatility should be considered when the instruments are actively traded and have a remaining term of at least six months (see discussion beginning at Paragraph 2.042).
- Length of time an entity's shares have been publicly traded.** If the period that an entity's shares have been publicly traded is shorter than the expected

term of the share option, the term structure of volatility for the longest period for which trading activity is available should be considered.¹⁰ A newly public entity also might consider the volatility of share prices of similar entities. However, because an entity's own data are generally perceived to be more reliable than *industry* or *peer company* data, an entity using peer group data should carefully evaluate why peer group data are more representative of its expected future volatility. One situation for which peer group data may be more representative of expected future volatility is when a newly public entity does not have sufficient share price history to calculate historical volatility for the expected term of the share option and its volatility to date has been closely correlated with the peer group. Use of peer group data also may be appropriate when the entity has significantly changed its structure through a major acquisition or disposition. In such situations, an entity may conclude that it is appropriate to weight peer company volatility with its historical volatility. The relative weights attached to its historical volatility versus peer company volatility would be expected to shift over time as more of its historical volatility information becomes available. For a nonpublic entity expected volatility may be based on the volatility of publicly traded entities that are otherwise similar. ASC paragraph 718-10-S99-1 notes that a newly public entity may identify peer companies from a sector index that is representative of its industry and its size. However, the volatility of the index should not be used because index volatility is reduced through the effects of diversification. Instead, the volatilities of the companies that constitute the index should be used. ASC paragraph 718-10-S99-1 also notes that a newly public company can look to the historical volatility of its stock measured over at least a two-year period, or over a shorter period when the expected term of the share option is shorter, as a reasonable basis for estimating its expected volatility if the entity has no reason to believe that its future volatility will differ significantly during the expected term of the share option.

- **The mean-reverting tendency of volatilities (i.e., volatility will tend to revert to a long-term average after periods of greater than or less than long-term average volatility).** For example, in computing historical volatility, an entity might give less consideration to an identifiable period of time in which its share price was extraordinarily volatile because of a failed takeover bid or a major restructuring. As described in Paragraphs 2.036 through 2.038, in certain limited situations it may be acceptable to completely exclude such periods while in other situations it may be acceptable to place less weight on those periods. The partial or total exclusion of a particular historical period of share price volatility, however, that is not representative of expected future volatility will depend on an entity's specific facts and circumstances. For example, for some entities, a proposed merger or acquisition may have prompted greater share price volatility for the period of the merger or acquisition, which is not expected to recur. For other entities, mergers and acquisitions are an integral part of the business strategy and such volatility may reasonably be expected to recur. An assumption of mean reversion may also cause an entity to place less weight on a period of

extremely high volatility that occurred because of a general market decline. Statistical techniques, such as Generalized AutoRegressive Conditional Heteroscedasticity (GARCH) may be used to forecast expected future volatility based on mean reversion principles. However, ASC paragraph 718-10-S99-1 notes that techniques that unduly weight more recent periods of historical volatility over earlier periods may be inappropriate when valuing longer-term share options and cites GARCH as an example.

- **Changes in operations or capital structure.** Changes in business and/or capital structure such as those resulting from a sale of a portion of a business may create situations where the remaining business(es) have a different volatility than that experienced historically. Similar situations may result from recent acquisitions. In addition, highly leveraged entities tend to have higher volatilities, so leverage and changes therein can affect the ability to apply either historical or peer data. ASC paragraph 718-10-55-37

2.040a In addition to the factors noted above, the SEC staff believe an entity should consider those future events that a marketplace participant would reasonably also consider in estimating volatility. The SEC staff noted that careful consideration is required to determine whether material nonpublic information is currently available (or would be available) to the entity that would be relevant to a market participant's estimation. Based on consideration of the individual facts and circumstances surrounding identified material nonpublic information, an entity must determine whether that information should be included in estimating the expected volatility. SAB Topic 14.D.1 Question 2, Item 4

Q&A 2.6: Calculating Volatility for a Newly Public Entity

Q. How should a company that recently became public compute expected volatility when calculating the fair value of the company's share options?

A. A company that does not have sufficient historical information should compute its expected volatility based on the average volatilities of similar entities for an appropriate period of time (as well as considering its volatility since becoming public). A company should evaluate its specific facts and circumstances to determine whether another company or group of companies is *similar* and whether the time period is *appropriate*. The company should consider the relative size, industry, and age of the company(ies) used.

2.041 ASC paragraph 718-10-S99-1 states that an *exclusive* reliance on historical volatility might be appropriate if:

- The entity has no reason to believe that its future volatility over the expected or contractual term, as applicable, is likely to differ from its historical volatility;

- The computation of historical volatility uses a simple average calculation method;
- A sequential period of historical data at least equal to the expected or contractual term of the share option, as applicable, is used; and
- A reasonably sufficient number of price observations are used, measured at a consistent point throughout the applicable historical period.

2.042 Implied Volatility. An entity generally should consider several possible indicators of expected volatility. The weight that should be assigned to each indicator depends on the particular facts and circumstances. ASC paragraph 718-10-S99-1 indicates that when implied volatility information is available for instruments with a remaining maturity in excess of six months, entities should generally consider the implied volatility measure.

2.043 The ability to reliably measure implied volatility depends on (1) how active the market is for the instrument from which implied volatility will be determined, (2) synchronizing the variables of the traded option used to calculate implied volatility with those in the share option (e.g., exercise price, measurement date), and (3) similarity between the length of the term of the traded option and that of the share options. When these traits are present, the indicated implied volatility should be used in the analysis of expected volatility. In addition, if these conditions are met even when the result is unusually high or low compared to prior periods or to historical volatility, adjustments to the *raw* implied volatility are inappropriate. However, see Paragraph 2.046, which discusses weighting of different measures of volatility.

2.044 One of the concerns about the use of implied volatility is the disparity between the term of typical exchange-traded options and the longer expected term of typical share-based payment awards. The SEC staff, however, will accept *exclusive* reliance on implied volatility in certain situations. The SEC staff indicated that they will not object to a company's exclusive reliance on implied volatility if the following six criteria are met:

- The entity uses a valuation model, such as Black-Scholes-Merton, based on a constant volatility assumption;
- Implied volatility is derived from share options that are actively traded;
- The market prices of both the traded options and the underlying shares are measured at a similar point in time and on a date reasonably close to the fair value measurement date of the share options;
- Traded options have exercise prices that are both near-the-money and close to the exercise price of the share options; and
- The remaining maturities of the traded options on which the estimate is based are at least one year, and
- Material nonpublic information that would be considered in a marketplace participant's expectation of future volatility does not exist.

2.045 While ASC paragraph 718-10-S99-1 indicates that companies can place exclusive reliance on implied volatility when all of the six criteria are met, there may also be other circumstances where companies can place exclusive reliance on implied volatility. For example, in situations where a company has modified an award, the modification may occur when the share option is either in- or out-of-the-money. While the fourth factor listed is not met in this situation, we understand that the SEC staff has not objected to a company's exclusive reliance on implied volatility (subject to the other conditions being met) in that situation. Similar circumstances could arise when determining the fair value of liability-classified awards in periods subsequent to the initial grant. We believe, however, that because of market characteristics that sometimes are referred to as the *volatility smile* (see Q&A 2.7), the most relevant measure of implied volatility would be found in traded options with *moneyness* that is similar to the awards being valued.

2.046 For many entities, it is possible to calculate both historical and implied volatility. These values may be significantly different, in which case a determination will need to be made about how much weight to place on each of the different sources of information. It is not possible to identify all factors to consider when evaluating the weight to be placed on different volatility data in a share option valuation and, ultimately this is a judgment that should be made based on an entity's particular facts and circumstances. However, the following factors may be relevant when selecting weightings to place on available implied and historical volatility data.

| Implied Volatility | Historical Volatility |
|--|---|
| The volume of trading activity | The frequency of available pricing observations |
| The proximity of trading activity to the grant or valuation date | The period of time of the observed data compared to the expected term |
| The moneyness of the traded options compared to the moneyness of the share options being valued | Mean reversion tendency of volatility and whether there are indications that the measured historical volatility is unduly higher or lower than longer-term trends |
| The term of the traded options compared to the expected term of the share options being valued | The inclusion of periods surrounding unusual events specific to the entity that are not expected to recur |
| The availability of implied volatility data from conversion features embedded in other financial instruments | Significant changes in the entity's risk profile, size, industry, or capital structure not fully reflected in the observed data |

| | |
|---|--|
| Observed trends in implied volatility data | Observed trends in historical volatility data |
| Whether there are unexplained differences compared to peer companies | Whether there are unexplained differences compared to peer companies |
| The possession of material nonpublic information by the entity | |
| Factors related to the market conditions in general, the entity's industry, or the entity's stock or other securities | |

2.047 It is generally inappropriate to arbitrarily place little weight on different measures of volatility, particularly when doing so will lower the volatility assumption. An entity should document how it considered the factors in the preceding table in developing the relative weights placed on different volatility data in any given valuation. That documentation should support not only the current valuation but also the reasons for changes to the weightings in different valuations. For example, in one period, measures of implied volatility and historical volatility may be similar and be supported by adequate trading volume and the absence of unusual activity to unduly affect either measure. In that situation, an entity might conclude that each measure is equally useful and, accordingly, weight each at 50%. In a different period, implied volatility may be much higher (or lower) than historical volatility. An analysis of the underlying data might help an entity determine whether this is the result of a change in expectations that has manifested itself more rapidly in implied volatility than historical volatility, the effects of unusual trading activity, reductions in trading volume, or some other factor. In turn, that could help the entity support the relative weight to place on each measure of volatility. If the entity concludes the implied volatility data is based on less robust trading activity than in the past, that conclusion might support a decision to reduce the weight placed on that data to, for example, 33%, and to place 67% weight on the historical volatility (in effect concluding that the historical volatility data is twice as useful as the implied volatility). Conversely, if the entity concludes that the implied volatility is robust and reflects a shift in the market's expectations not yet fully manifested in the historical volatility measure, it might conclude to shift the weights to 67% on implied volatility and 33% on historical volatility.

Q&A 2.7: Reconciling Differing Estimates of Historical and Implied Volatility

Q. ABC Corp. issues share options with a contractual term of 10 years to employees. The company estimates that the share options have an expected term of five years. ABC determines that historical volatility of its shares over the last five years was 40%. Implied volatility, based on traded six-month options, is currently 20%. What should ABC consider when reconciling the historical and implied volatility data?

A. ABC should initially calculate the historical volatility of its stock price returns over a historical period commensurate with the expected term of the award. ABC should then consider how expected volatility may differ from historical volatility using measures such as implied volatility as well as any trend in the historical volatility. Implied volatility is generally thought of as the *market's* estimate of the share price's future volatility over the term of the traded options. However, the term of the traded options is significantly shorter than the expected term of the employee share options. The employee share options in this example have a five-year expected term, so the implied volatility measure is only available for a small portion of the share options' term. An entity should not base its estimate of the expected volatility of the shares underlying a share-based payment arrangement solely on the implied volatility estimate derived from a traded instrument with a remaining term that is less than one year (see conditions for exclusive reliance on implied volatility in Paragraph 2.044). The entity should consider how the volatility of its shares may change from the expiration date of the traded instrument to the end of the expected term of the share-based payment.

ASC paragraph 718-10-S99-1 indicates that companies should generally consider implied volatility when available for traded instruments with a remaining maturity of six months or more. In determining the weight given to implied volatility and historical volatility, an entity generally should consider the volume of option contracts traded that (1) have remaining maturities of at least six months and (2) are close to the money. In assessing whether the market for traded options from which implied volatility estimates are derived is *active* or not, companies should not aggregate all traded options. Rather, only those that meet the criteria on *moneyness* and expected term should be used. Implied volatility of exchange traded options can vary based on the moneyness of the options (i.e., the relationship of current underlying stock price to exercise price). These different volatilities observed at different amounts of moneyness are referred to as the *volatility smile* or the *volatility skew*.

Greater traded option volumes, which are derived from a more active market, give rise to a more reliable estimate of implied volatility because the estimate represents the aggregate consensus of marketplace participants. Smaller trading volumes reflect the interaction of fewer marketplace participants and, therefore, are less reliable. Where traded option volumes are very small, a company may not be able to place much reliance on implied volatility. Additionally, implied volatility is time sensitive. As a result, estimates closer to the valuation date should be weighted more heavily than implied volatility estimates from other dates.

Example 2.1: Weighting Volatility – Part I

Company A has publicly traded shares outstanding. However, Company A's shares have only been publicly traded for 18 months. The historical volatility of the shares during that period is 45%. Company A does not have any actively traded options in the marketplace. The expected term for Company A's share option awards is four years. Company A determines that because the period for which historical volatility is available is

significantly less than the expected term of the share options, historical volatility may not provide sufficient evidence of the expected volatility for the expected term of the share options. Based on the guidance in ASC paragraph 718-10-55-37(c), Company A will consider the historical volatility of a peer group of similar entities in addition to its own historical volatility. Company A determines that while each set of data is useful, the relative usefulness is about equal and, therefore, the following weighting of historical and peer-company data is appropriate:

| Data | Volatility | Weight | Weighted Volatility |
|-------------------------|-------------------|---------------|----------------------------|
| Company A volatility | 45% | 50% | 22.5% |
| Peer volatility (4 yr.) | 36% | 50% | 18.0% |
| Expected volatility | | | <u>40.5%</u> |

Example 2.2: Weighting Volatility – Part II

Company B has publicly traded shares. Company B has been public for four years, however, for the first two years after becoming a public company, Company B's stock was very thinly traded on an over-the-counter market. For the past two years, Company B's stock has been actively traded on a national exchange. The expected term on its employee share option awards is five years. Because the expected term is greater than the historical volatility data and because the stock was thinly traded for a portion of the historical period, Company B determines that it is appropriate to consider peer company volatility data for a period commensurate with the term of the share options together with the company's historical data over its four-year history and over the two-year period when its stock was actively traded. Based on its analysis of the available data, Company B determines that the longer term historical volatility of its own stock and its peers has equal utility and that the shorter term volatility of its own stock is more indicative of expected long-term trends. Accordingly, the following weighting of historical and peer-company data is appropriate:

| Data | Volatility | Weight | Weighted Volatility |
|------------------------------|-------------------|---------------|----------------------------|
| Company B volatility (4 yr.) | 65% | 30% | 19.5% |
| Company B volatility (2 yr.) | 40% | 40% | 16.0% |
| Peer volatility (5 yr.) | 35% | 30% | 10.5% |
| Expected volatility | | | <u>46.0%</u> |

Example 2.3: Weighting Volatility – Part III

Company C has publicly traded shares and exchange-traded options. Company C does not qualify for exclusive reliance on implied volatility (see Paragraph 2.044). However, the Company determines that some reliance on implied volatility is appropriate.

Company C has been publicly traded for 10 years and the expected term of its employee share options is estimated to be five years. Company C's stock experienced a period of high volatility approximately four years ago, which is included in its five-year historical volatility. Based on its analysis of the available data, Company C determines that while each set of data is useful, the relative usefulness is about equal and, therefore, the following weighting of historical and implied volatility data is appropriate:

| Data | Volatility | Weight | Weighted Volatility |
|------------------------------|------------|--------|---------------------|
| Company C volatility (5 yr.) | 60% | 50% | 30.0% |
| Company C implied volatility | 30% | 50% | <u>15.0%</u> |
| Expected volatility | | | 45.0% |

Example 2.4: Weighting Volatility – Part IV

Company D has been a publicly traded company for many years. The expected term of its employee share options is four years. Company D's historical volatility over the most recent four-year period has been greater than its long-term historical volatility. As a consequence, Company D determines that it is appropriate to use a period of time longer than its expected term to calculate its historical volatility. Doing so, in effect, demonstrates a mean-reversion of its historical volatility from the more recent period of high volatility. Based on its analysis of the available data, Company D determines that the longer-term volatility is more useful because it more accurately reflects the mean reversion tendency of volatility and inherently places less weight on a period of higher volatility included in the five-year measure. Company D determines that the following weighting of historical data is appropriate:

| Data | Volatility | Weight | Weighted Volatility |
|-------------------------------|------------|--------|---------------------|
| Company D volatility (5 yr.) | 60% | 40% | 24.0% |
| Company D volatility (10 yr.) | 45% | 60% | <u>27.0%</u> |
| Expected volatility | | | 51.0% |

2.048 Calculated Value. If it is not possible for a nonpublic entity to make a reasonable estimate of fair value because it is not practicable to make a reasonable estimate of its volatility, the nonpublic entity is required to use an alternative measurement method. The alternative measurement method deals with estimating expected volatility, which is the

most problematic measurement difficulty that nonpublic entities face. Under the alternative measurement method, a nonpublic entity uses a calculated volatility, determined by applying the historical volatility of an appropriate index of public entities, as an input to a valuation model, rather than using zero volatility as previously permitted by Statement 123. An appropriate index should include entities in the same industry and, if possible, the same size as the entity. However, because ASC Topic 718 requires nonpublic entities to first look to volatility measures of a group of peer entities before concluding that it is impracticable to estimate its volatility, it is likely that many nonpublic entities will be able to determine a supportable measure of expected volatility; in which case, they would use fair value in measuring the share option rather than the calculated-value method.

2.049 Use of the alternative-measurement method is not a policy decision. The conditions that an entity must meet to use this alternative are based on the general presumption that an entity should determine fair value using entity-specific expected volatility, unless it is not practicable to do so.

2.050 ASC paragraphs 718-20-55-77 through 55-83 present some of the factors that might cause a nonpublic entity to conclude that it is not practicable for it to estimate its own stock price volatility. The factors identified indicate that use of calculated value should not be assumed to be the default position for nonpublic companies. In ASC paragraphs 718-20-55-77 through 55-83, it was determined that it was not practicable to estimate stock price volatility because:

- The company did not maintain an internal market for its shares, which rarely traded privately.
- The company had not issued any new equity or convertible debt instruments for several years.
- The company was unable to identify any similar entities that were public.

The guidance given in ASC paragraphs 718-20-55-77 through 55-83 relates to the specific facts within those paragraphs, and any evaluation should be based on an entity's specific facts and circumstances.

Q&A 2.8: Calculating Fair Value of a *Formula Based* Share Award of a Nonpublic Company

Q. ABC Corp. is a nonpublic company whose shares are not publicly traded. As a consequence, ABC uses a formula to estimate the value of its stock and the related volatility for purposes of its share-based payment arrangement. The formula price of the underlying share is based on a constant multiple of the entity's earnings. While it is recognized that the formula price of the share is not necessarily the value ABC's shares would command in an exchange transaction, based on specific facts of ABC's plan, it is considered appropriate to use the formula price as a surrogate for the fair value of the shares (consistent with ASC paragraphs 718-10-55-131 through 55-133). When

determining the volatility input to use in the calculation of the fair value of a formula-based share award, is it appropriate to use internally established value or marketplace comparables?

A. The volatility input should be based on changes in the formula price of the share over time in the entity's internally established value because the award holder experiences economic volatility from the formula price, which is based on ABC's earnings.

2.051 As discussed in Paragraph 2.001, if it is not practicable for a nonpublic entity to reasonably estimate the fair value of its awards because it cannot make a reasonable estimate of the expected volatility of its share price or the expected volatility of peer companies, then the nonpublic entity is required to use the calculated value method, which uses the historic volatility of an appropriate index. In most cases, it should be possible for a company to derive its expected volatility directly from peer companies or by using the volatility of the companies that make up the appropriate index. When a nonpublic entity uses the calculated value method to calculate historical volatility, it uses the index's historical daily closing values through the period prior to the grant date that is equal in length to the share option's expected term. If the daily closing values are not readily available for the entire expected term, a nonpublic entity uses the closing values for the longest period of time available. The method should be applied consistently. A consistent method should also be used when measuring awards that were modified. If an award whose grant-date fair value was determined using an alternative measurement method is subsequently modified, the value of the modified award should be determined using the same alternative method. In the limited situations in which use of an appropriate index was necessary when measuring previous grants, a nonpublic entity may change its measurement method for subsequent grants from calculated value to fair value because either the entity becomes public or the entity is able to estimate volatility of its own shares. ASC paragraph 718-10-55-27 states that a change in either the valuation technique or the method of determining appropriate assumptions used in a valuation technique is a change in an accounting estimate when applying ASC Subtopic 250-10 and should be applied prospectively to new awards (see KPMG Handbook, Accounting changes and error corrections, Question 3.2.50 and Chapter 3). All share-based payments granted subsequent to the change are measured using fair value and compensation cost for unvested awards granted before the change continues to be recognized based on the calculated value. However, an entity generally would not be allowed to change its method of estimating the value of share-based payment arrangements from the fair value method to calculated value method. This is because, for this change in estimate, an entity would need to support why it could previously estimate its expected volatility, but subsequently could no longer estimate it. ASC paragraph 718-10-55-58

Expected Dividends

2.052 Dividends affect the value of a share option because the share price will fall as a result of the dividend. If the share option holder will not receive dividends (or the equivalent) paid during the vesting period, the dividends expected to be paid during the vesting period will reduce the value of the share option. Common share option valuation

models, such as Black-Scholes-Merton factor this into determining fair value by incorporating an assumption about expected future dividends that is subtracted from the value that would otherwise result from applying the formula.

2.053 While option pricing models generally use the expected dividend yield, models may be modified to use an expected dividend amount rather than a dividend yield. If an entity uses expected dividend amounts, any history of regular increases in dividends should be considered. For example, if a company's policy has been to increase dividends every year, its estimate of the fair value of the share option should not be based on a fixed dividend amount throughout the expected term of the share option.

2.054 It may be more appropriate to use dividend amounts rather than dividend yields when the indicated yield is unusually high or low for the entity compared to its historical trends. Despite this observed short-term relationship, using a disproportionately high dividend yield implicitly assumes the liquidation of the entity in a relatively short period of time. That assumption generally would not be reasonable from a market participant's perspective. In the longer term, the market will eventually either reflect an increase in the stock price because of the attractiveness of the dividends, or the dividends will be reduced due to lower earnings or available cash, or some combination of both. For example, if the stock price has declined significantly but the entity does not intend to (or has not yet) cut its dividend amount, the short-term dividend yield could be 20% or higher, even when the normalized dividend yield for the entity could be 3-5%. Because that yield is unusually high, it is probably more appropriate in this situation to employ a valuation model that uses the dividend amount rather than a dividend yield. It also may be acceptable to determine what the expected long-term yield will be and use that as an input into the valuation model. However, it would not be appropriate in this situation to assume that the stock price will increase and use the higher stock price as an input into the valuation model. ASC paragraph 718-10-55-42

2.055 Some entities with no history of paying dividends might reasonably expect to begin to pay dividends during the expected term of their share options. The entities should consider this in the dividend rate assumption.

2.056 The expected dividend rate used in option pricing models generally is a continuously compounded rate, which differs from the quoted rate available from pricing services or published in the financial press. Care should be taken when inputting data into an option pricing model to ensure that the dividend rate is expressed on the correct basis. One can convert from a periodically compounded dividend yield to a continuously compounded dividend yield using the formula below, where qcc is the continuously compounded dividend yield, qp is the periodically compounded dividend yield, and n is the number of compounding periods per year (e.g., one for an annually compounded dividend yield), and Ln is the natural logarithmic function:

$$qcc = n \times \text{Ln}((1+qp/n))$$

2.057 Some share option awards include dividend protection features. For example, the exercise price on a share option may be reduced by the amount of dividends paid on the

underlying stock, which protects the share option holder from declines in the stock price associated with the payment of a dividend. As a substantive feature of the award, the dividend protection feature should be considered in the fair value of the share option. When a share option's exercise price is reduced to reflect the payment of a dividend on the underlying stock, the effect on the share option's fair value can be incorporated in an option pricing model by using a zero-dividend yield assumption. The payment of a dividend will reduce an entity's share price but this can be offset by an equivalent reduction in the exercise price when the share options are adjusted by a dividend protection feature. As a result, the intrinsic value of a dividend-protected award at exercise would be the same as the intrinsic value of a share option on a share that does not pay dividends. An alternative dividend protection feature is to pay dividends to option holders. In such circumstances, when grantees are not required to return dividends received on unvested awards that are forfeited, additional compensation cost is recognized for the amount of those dividends on awards that do not vest. Dividends paid on awards that ultimately vest are charged to retained earnings. If an entity makes an accounting policy election to account for forfeitures when they occur, the entity would reclassify to compensation cost in the period in which the forfeitures occur the amount of dividends and dividend equivalents previously charged to retained earnings related to awards that are forfeited (which will partially offset the reversal of previously recognized compensation cost on the forfeited awards). See Paragraph 4.122 for additional discussion of accounting considerations for dividends on awards. ASC paragraphs 718-10-55-44 through 55-45

2.057a A share option award where the holder is eligible to receive cash dividends prior to exercising the award has greater value than a share option award with a dividend protection feature, as described in Paragraph 2.057. This is because with a dividend protection feature, the holder has to exercise the award to realize the value of the dividends. As a result, when valuing a share option award that remits cash dividends to the holder, two separate awards with fair values are considered:

- *For the cash dividends:* calculate the present value of the estimated dividend payments that will be received, and
- *For the value of the share option award:* ignore the cash dividend payment, and calculate the value using an option-pricing model.

2.058 If an entity grants an in-the-money share option award on a stock with a high dividend yield, the fair value on the date of grant conceptually should equal or exceed the intrinsic value of the share option on the grant date. However, in situations where the dividend yield is high relative to the risk-free rate, the fair value calculated using the normal inputs to the stock option pricing model may be less than the intrinsic value of the share option. In that situation, we believe the entity should use the intrinsic value as the grant-date fair value of the share option. For example, if an entity grants a share option with an exercise price of \$20 on a stock whose current market price is \$25 and the fair value of the share option is calculated as \$4, the entity would use the intrinsic value of \$5 (\$25 less \$20) as the grant-date fair value of the share option.

Expected Risk-Free Rate

2.059 For share options that a U.S. entity grants on its own shares, the risk-free interest rate used should be the rate currently available on zero-coupon U.S. Treasury instruments with a remaining term equal to the expected term of the share options when using a Black-Scholes-Merton model or for the contractual term when using a lattice model. For share options issued by entities based in jurisdictions outside the United States, the risk-free rate used should be the implied yield currently available on zero-coupon government issues denominated in the same currency as the primary market on which the shares trade. ASC paragraph 718-10-55-28

2.060 There is an observed term structure of interest rates, that is, different rates of interest for different periods of time can be inferred from the prices of bonds with different maturities. This is sometimes referred to as the yield curve.¹¹ As a result, the yield on securities of different maturities, including long-dated securities, is readily available from pricing services or the financial press.

2.061 The risk-free rate used in existing option pricing models is a continuously compounded rate, which differs from the quoted rate available from pricing services or the financial press. Care should be taken when inputting data into an option pricing model to ensure the risk-free rate is expressed on the correct basis.

Expected Share Option Term

Note: This section discusses factors that an entity should consider in determining the expected term of a share option used in estimating the fair value of awards. These considerations would not apply to a nonpublic entity that has elected to apply the practical expedient discussed under Paragraph 2.030a.

2.062 In general, exchange-traded options are not exercised before expiration. Holders of exchange-traded options who want liquidity can simply sell the traded option in the marketplace. However, employee share options are nontransferable. As a result, employees must exercise the share option and sell the underlying shares to obtain liquidity. Entities are required to use the expected term of a share option rather than the contractual term to reflect the fact that employee share options, when in-the-money, are often exercised before their contractual maturity. Because early exercise is considered in estimating the fair value of a share option, it is inappropriate to apply a discount to the output of an option pricing model to reflect the illiquidity of the share option. Further, for nonemployee awards, on an award-by-award basis, an entity may elect to use the contractual term as the expected term when estimating the fair value, as the nonemployee exercise patterns are not always known or determinable. If an entity does use the expected term for nonemployee awards, similar considerations, such as the inability to sell or hedge a nonemployee award, apply when using the simplified method - see Paragraph 2.025.

2.063 Entities should consider the likelihood of early exercise in estimating the fair value of awards. However, the manner in which an entity incorporates early exercise depends on its selection of an option pricing model. For example:

- Entities that apply the Black-Scholes-Merton model can only reflect early exercise through the expected term input into the model.
- Entities that use a lattice model may identify specific factors that influence early exercise and incorporate these factors directly into the model. For example, entities may be able to identify a tendency for grantees to exercise share options at a certain multiple of the exercise price, which ASC Topic 718 refers to as the suboptimal exercise factor. To illustrate, an entity may be able to demonstrate that a particular group of its grantees tend to exercise share options when the market price of the underlying shares is twice the exercise price. This would result in a suboptimal exercise factor of two. This assumption can be directly incorporated into a lattice model. In addition, a lattice model can reflect postvesting terminations or departures, which would cause a departing grantee to either exercise a share option, if it is in-the-money on the departure date, or have it expire unexercised, if it is out-of-the-money at that time.¹² For a lattice model, expected term is an output from the model rather than an input.¹³

2.064 The Black-Scholes-Merton model uses the expected term to reflect early exercise; therefore, the expected term of a share option award should be estimated based on reasonable facts and assumptions on the grant date. The following factors should be considered in estimating the expected term when the Black-Scholes-Merton model is used:

- The vesting period of the award. A share option's expected term is at least as long as the vesting period.
- Employees' past exercise and postvesting employment departure behavior for similar grants.
- Expected volatility of the price of the underlying share.
- Blackout periods and other coexisting arrangements, such as agreements that allow for exercise to automatically occur during blackout periods if certain conditions are satisfied.¹⁴ ASC paragraph 718-10-55-31

2.065 ASC Topic 718 identifies several other factors influencing employees' early exercise decisions: (1) employee's age, (2) length of service at the entity, (3) the employee's home jurisdiction (foreign or domestic), (4) relevant and supportable external information, (5) aggregation of individual awards into homogeneous groups, and (6) the evolution of the stock price during the share option term. The first three factors would likely not be directly considered in the valuation model. Instead, they would be considered when grouping similar employees to identify exercise behavior (fifth factor). In addition, for the sixth factor, the evolution of the stock price, because a lattice model develops stock price paths over the share option's contractual term, exercise behavior

based on the evolution of the stock price could be considered in the model. However, the Black-Scholes-Merton model values an option based on the expected risk-neutral stock prices at expiration and does not consider stock prices before expiration. As a result, the Black-Scholes-Merton model is unable to directly incorporate the effect of early exercise from the pre-expiration evolution of the stock price. ASC paragraph 718-10-55-31, 55-32, 55-34

2.065a An additional factor that may influence an employee's early exercise decision is the expected dividend yield. In general, employees receiving options are only entitled to dividends (if any) paid by the underlying stock once the option is exercised. Therefore, the presence of dividends could entice an employee to exercise options earlier and should be considered when determining the expected term. If the Company's dividend policy changes for the holding period relative to the historical benchmarking period, the Company should consider adjusting its expected term to account for the incremental incentive for early exercise.

Q&A 2.9: Valuation Assumptions When Share Options Are Exercisable Prior to Vesting

Q. A company grants share options with an exercise price equal to the market price of the company's shares at the date of grant with cliff vesting after four years. However, the share option agreement provides that the employee can exercise the share option at any time between the grant date and the expiration of the share option 10 years later. Shares that are acquired through exercise of share options before the vesting date are subject to repurchase by the company at the exercise price paid by the employee if the employee terminates employment prior to the completion of the vesting requirements.

Is it appropriate for the expected term used in an option pricing model to be less than the vesting period? For example, if a company expects employees to exercise their share options an average of one year after the grant date (i.e., three years prior to vesting), can one year be used as the expected term?

A. No. The expected term used in the option pricing model should be equal to or greater than the vesting period. The mandatory share repurchase feature for employees who leave the company means that the four-year vesting period is substantive and would constitute the minimum period for the expected term of the share options.

2.066 While a share option's fair value increases as the expected term of the share option increases (holding all other inputs constant), the relationship between the expected term and the fair value of the share option is not linear. For example, a two-year share option is worth less than twice as much as a one-year share option if all other inputs are equal. As a result, use of a single input for the expected term for all share options granted when there is a wide range of individual behaviors may overstate the value of the award. Consequently, to obtain a more representative fair value, share option recipients should be grouped into relatively homogeneous groups and the related share option fair values should be based on appropriate estimates of expected term for each group. For example,

if top-level executives tend to hold their share options longer than middle management, while nonmanagement employees tend to exercise their share options sooner than other groups, it may be appropriate to stratify the employees into three groups in calculating the expected term of the share options for each group. ASC paragraph 718-10-S99-1 suggests that as few as one or two groupings may be sufficient in certain circumstances to make reasonable fair value estimates. ASC paragraphs 718-10-55-32 and 55-33

2.067 The ability to apply a lattice model will depend on the availability of reliable input information. Information may be available from either external or internal sources. For example, valuation specialists may gather databases of grantee early exercise behavior observed on a number of share-based compensation valuation engagements, which may be useful when internal data is insufficient or the relationships indicated from internal data are not statistically significant. Entities will need to assess when to appropriately apply external information to arrive at factors for early exercise behavior that are reasonable predictors in the future.

2.068 Some entities make changes to the contractual term of their share option grants. Other entities change their conditions for vesting by including performance conditions, in addition to service conditions, in the awards. While there is no generally applicable formulaic approach, these entities should consider the effect of the change in share option terms on exercise behavior when estimating the expected term of the share option. Changes in the share options' terms may affect the reliability of the entities' historic information when used as a basis for estimating the expected term of the share option.

2.069 In developing historical data about exercise behavior, companies should consider all postvesting experience, including share options that are exercised, canceled, and currently vested but unexercised. In some cases, there may also be options that vested but were never exercised because they expired out of the money while the holder was still an employee. An entity treats those vested options as though they were exercised at expiration to reflect the period the awards were held by the employee. The average term for exercised and canceled awards can be computed based on the company's historical experience. However, companies also should consider the consequences of currently unexercised awards on the historical exercise experience to develop an assumption about the remaining term for unexercised awards in computing its historical exercise experience. No one assumption is necessarily required. For example, one approach may be to assume that unexercised share options will be exercised evenly over the remaining contractual term of the share options. This method is similar to the *simplified method* described in Paragraphs 2.025 through 2.029. However, a key difference from the *simplified method* is that the population of vested awards is divided into different categories (awards already exercised, those cancelled or expired, and those vested but unexercised). Actual exercise data is used for awards already exercised or cancelled. For those awards that remain unexercised and outstanding, even exercise over the remaining contractual term is assumed. Each category is weighted for its relative size in the population and is then multiplied by the indicated expected term for each category to arrive at the expected term for the population. Note that when using this method, it may be appropriate to assume faster or slower than even exercise over the remaining period depending on the moneyness of the awards. It also may be appropriate to exclude some

grants from the analysis if the moneyness of the awards becomes unusually high or low during the term of the awards to such a degree that they are not considered representative of the expectations for current at-the-money grants. If that is done, care should be taken to ensure that the analysis is balanced toward removing outliers that either increase or decrease the calculated expected term. Three ways to adjust for unusually high or low moneyness are (1) use an increased amount of historical data to dilute the effect of periods that are not reflective of future behavior, (2) use information from academic studies as an additional data point, and (3) use an approach similar to the *simplified method*.

Example 2.5: Expected Term Calculation

| Grant Year | Strike Price | Sum of Net Granted | Exercised | Average Period to Exercise | Post Vesting Expiry | Average Period to Expire | Un-exercised | Average Outstanding Term |
|------------|--------------|--------------------|------------------|----------------------------|---------------------|--------------------------|------------------|--------------------------|
| 1996 | \$1.00 | 200,000 | 175,000 | 5 | 25,000 | 3 | 0 | 9 |
| 1997 | \$2.00 | 275,000 | 33,332 | 4 | 27,500 | 4 | 214,168 | 8 |
| 1998 | \$4.00 | 350,000 | 166,666 | 6 | 30,300 | 6 | 153,034 | 7 |
| 1999 | \$3.00 | 425,000 | 26,666 | 4 | 33,300 | 4 | 365,034 | 6 |
| 2000 | \$6.00 | 500,000 | 350,000 | 4 | 36,600 | 2 | 113,400 | 5 |
| 2001 | \$20.00 | 575,000 | 250,000 | 3 | 40,300 | 5 | 284,700 | 4 |
| 2002 | \$11.00 | 650,000 | 0 | 2 | 44,300 | 5 | 605,700 | 3 |
| 2003 | \$9.00 | 725,000 | 0 | 2 | 48,700 | 2 | 676,300 | 2 |
| 2004 | \$7.00 | 800,000 | 0 | 1 | 53,600 | 1 | 746,400 | 1 |
| 2005 | \$13.00 | 875,000 | 0 | 0 | 0 | 0 | 875,000 | 0 |
| | | <u>5,375,000</u> | <u>1,001,664</u> | | <u>339,600</u> | | <u>4,033,736</u> | |

Assume a company has the above share option history.

- The Sum of Net Granted column represents total options granted, net of estimated forfeitures. The entity's accounting policy is to estimate the number of awards expected to be forfeited in accordance with ASC paragraph 718-10-35-3.
- The Average Period to Exercise column represents the average number of years from date of grant until exercise.
- The Average Period to Expire column represents the number of years from date of grant until the expiration of an award.
- The Average Outstanding Term column shows the outstanding term of unexercised options from the date of grant until the present.

The raw data shown in the previous table is used to calculate the expected term as follows.

2. Measurement of Awards

| Grant Year | Remaining Life of Unexercised | | | Weighting (By Total) | | | | Total Weighted Life Even | | |
|------------|-------------------------------|----------|------|----------------------|---------|-------------|--------|--------------------------|----------|------|
| | Min | Exercise | Max | Exercised | Expired | Unexercised | Total | Min | Exercise | Max |
| 1996 | 9.0 | 9.5 | 10.0 | 3.3% | 0.5% | 0.0% | 3.7% | 0.18 | 0.18 | 0.18 |
| 1997 | 8.0 | 9.0 | 10.0 | 0.6% | 0.5% | 4.0% | 5.1% | 0.36 | 0.40 | 0.44 |
| 1998 | 7.0 | 8.5 | 10.0 | 3.1% | 0.6% | 2.8% | 6.5% | 0.42 | 0.46 | 0.50 |
| 1999 | 6.0 | 8.0 | 10.0 | 0.5% | 0.6% | 6.8% | 7.9% | 0.45 | 0.59 | 0.72 |
| 2000 | 5.0 | 7.5 | 10.0 | 6.5% | 0.7% | 2.1% | 9.3% | 0.38 | 0.43 | 0.49 |
| 2001 | 4.0 | 7.0 | 10.0 | 4.7% | 0.7% | 5.3% | 10.7% | 0.39 | 0.55 | 0.71 |
| 2002 | 4.0 | 7.0 | 10.0 | 0.0% | 0.8% | 11.3% | 12.1% | 0.49 | 0.83 | 1.17 |
| 2003 | 4.0 | 7.0 | 10.0 | 0.0% | 0.9% | 12.6% | 13.5% | 0.52 | 0.90 | 1.28 |
| 2004 | 4.0 | 7.0 | 10.0 | 0.0% | 1.0% | 13.9% | 14.9% | 0.57 | 0.98 | 1.40 |
| 2005 | 4.0 | 7.0 | 10.0 | 0.0% | 0.0% | 16.3% | 16.3% | 0.65 | 1.14 | 1.63 |
| | | | | | | | 100.0% | 4.41 | 6.46 | 8.51 |

The first row of numbers is calculated as follows (all other rows follow a similar logic).

- The first three columns derive from the previous table of information. In particular, the Min column represents the outstanding life of currently unexercised options. The Max column represents the contractual term of the option award. The Even Exercise column represents the simple average between the Min and Max columns.
- The Exercised percentage column is calculated by dividing the 175,000 options exercised (as shown previously) by the 5,375,000 in net options granted (i.e., total options, net of forfeitures) over the 10-year period under examination. The Expired and Unexercised percentages are calculated similarly.
- The Total percentage column is the sum of the Exercised, Expired, and Unexercised percentages. Rounding differences may exist.
- The minimum column represents the following formula:

$[\text{Exercised \%} \times \text{Period to Exercise}] + [\text{Cancelled \%} \times \text{Period to Cancel}] + [\text{Unexercised \%} \times \text{Min}]$

For instance, the Min amount of 0.18 in row 1 is calculated as follows:

$$[3.3\% \times 5 \text{ years}] + [0.5\% \times 3 \text{ years}] + [0\% \times 9.0 \text{ years}] = 0.18$$

The Even Exercise and Max columns are similarly calculated, except that the last step of the formula substitutes the remaining life figures for Even Exercise and Max in lieu of Min.

Based on the outcome of the expected life calculation the expected term assumption should be set somewhere between 4.41 and 8.51 years.

Dilution

2.070 Exchange-traded options are frequently written by a third party and exercising those share options does not result in an increase in the total number of the entity's shares trading in the marketplace. In contrast, an entity issues share option awards to employees and nonemployees. As a consequence, exercise leads to an increase in the number of shares outstanding. When the market does not perceive share option grants as increasing the value of the granting entity, because, for example, perceptions that the share options do not sufficiently incentivize management, issuing share options may lead to a dilution of existing shareholder value. Entities should consider whether the possible dilutive effect of share options granted would have an effect on the share price input and, accordingly, the grant-date fair value measure of the share option.

2.071 Option pricing models can be adapted to consider the potential dilutive effect of the share option. However, it is generally assumed that investors have considered such grants in valuing the entity's shares. As a result, ASC Topic 718 indicates that it would be unusual for a public entity to consider a dilution adjustment in determining grant-date fair value for a share option. However, in the case of a very large share option grant in relation to the number of shares currently outstanding that had not been anticipated by investors, the share price may adjust downward when the grant is announced. In this situation, the share price immediately after the announcement of the grant should generally be used in the option pricing model. ASC paragraph 718-10-55-48 through 55-50

Credit Risk

2.072 An entity may need to consider the effect of its credit standing on the estimated fair value of awards that contain cash settlement features, which would make the award liability-classified, because cash settlement of the awards is not independent of the entity's risk of default. Any credit-risk adjustment to the estimated fair value of liability-classified awards that increases in value with an increase in the price of the underlying share, can be expected to be de minimis because increases in an entity's share price generally are positively associated with its ability to pay its obligations. However, a credit-risk adjustment may be required to the estimated fair value of liability-classified awards that increase in value in response to a decrease in the price of the entity's shares. The underlying basis for the credit-risk adjustment should be carefully evaluated to determine whether it is causally linked to a decrease in the entity's share price. Such awards are likely to be rare because they fail to align the interests and incentives of management and shareholders (i.e., share option holders profit when the share price declines). ASC paragraph 718-10-55-46

Vesting Conditions

2.073 A service condition is a condition affecting the vesting, exercisability, exercise price, or other pertinent factors used in determining the fair value of an award that depends solely on an employee rendering service to the employer for the employee's requisite service period or a nonemployee delivering goods or rendering services to the

grantor over a vesting period. A condition that results in the acceleration of vesting in the event of a grantee's death, disability, or termination without cause is a service condition. A performance condition is a condition affecting the vesting, exercisability, exercise price, or other pertinent factors used in determining the fair value of an award that relates to both (a) rendering services or delivering goods for an explicit or implicit period of time, and (b) achieving a specified performance target that is defined solely by reference to the grantor's own operations (or activities) or by reference to the grantee's performance related to the grantor's own operations (or activities). Examples of performance conditions include attaining a specified rate of return on assets, obtaining regulatory approval to market a specified product, selling shares in an initial public offering, or a change in control. A performance target also may be defined by reference to the same performance measure of another entity or group of entities. For example, attaining a growth rate in earnings per share that exceeds the average growth rate in earnings per share of other entities in the same industry is a performance condition. A performance target may pertain to the performance of the entity as a whole or to some part of the entity, such as a division, or to the performance of the grantee if the performance is in accordance with the terms of the award and solely relates to the grantor's own operations. Service or performance conditions that affect vesting are not considered in the grant-date fair value of share options. Instead, service and performance vesting conditions are captured by only recognizing compensation cost for those share options that ultimately vest, i.e., for those awards for which the service or performance vesting conditions are ultimately met (see Section 4, *Recognition of Compensation Costs*). In essence, when the overall expense consists of price (or value) per share option (p) multiplied by quantity (q), the service and performance conditions that affect vesting are taken into account in adjusting q , not by adjusting p . ASC paragraphs 718-10-55-57 through 55-58

2.074 However, service and performance vesting conditions indirectly affect value of share options. Service and performance conditions are considered in estimating the expected term of the share option (i.e., the expected term of the share option should be at least as long as the vesting period). However, because service or performance conditions that affect vesting are not considered in the grant-date fair value of share options, no discounts associated with the restrictions during the vesting period, whether calculated as a discount applied directly against the results of the option pricing model or embedded in the share option valuation model itself, should be considered in arriving at the grant-date fair value of a share option. ASC paragraph 718-10-55-31

2.075 As discussed in Paragraph 4.100, awards that contain a *performance* condition with an explicit stated service period (e.g., the award vests if the company's average EPS over the next three years exceeds \$4.00 per share) would meet the ASC Section 718-10-20 definition of a performance condition even when the performance condition may be met after the employee's requisite service period or a nonemployee satisfies a vesting period. That is, the grantee would be eligible to vest in the award regardless of whether the grantee is rendering services or delivering goods on the date the performance target is achieved. For example, an award may include a three-year stated service condition and an earnings-based performance condition but the employee is eligible to retire or the nonemployee has satisfied its vesting condition and is entitled to receive the award even

if he or she has not met the performance condition. Under Topic 718, the award will be viewed as having a service condition and a performance condition, with no special valuation considerations (the likelihood of meeting the performance condition is not reflected in the grant date fair value). See Paragraphs 4.100 and 4.100a for additional discussion of the accounting for these types of awards.

2.076 Not used.

Q&A 2.10: Valuing a Share Option Award with a Performance Condition that may be Met After an Employee's Requisite Service Period

Q. Should a *performance* condition that may be met after the employee's requisite service period be incorporated into the grant-date fair value measurement of an award?

A. No. Topic 718 indicates that a *performance* condition is deemed to meet the definition of a vesting condition and is accounted for as such. For example, this situation may arise when a company grants awards containing performance conditions and some of the grantees either are retirement-eligible at the date of grant or will become retirement-eligible before the end of the stated service period. The award still may be retained even if the employee retires, provided that the *performance* condition is met.

For example, Company A issues an award of nonvested stock to employees when the stock price is \$10 per share. The award *vests* on achievement of a growth in EPS of 30% over the next three years. Employees who retire are entitled to retain the award, subject to the achievement of the EPS target. Therefore, for those employees, the award will not be exercisable unless the EPS target is reached. Assume management has assessed that the achievement of the EPS target is probable.

The grant-date fair value of the award would be measured based on the stock price at the date of grant. The grant-date fair value of the awards of \$10 per share would be recognized immediately (for those who are retirement-eligible at the date of grant) or over the employees' requisite service period (for those who will become retirement-eligible before the end of the three-year stated service period). For the employees who will not become retirement-eligible before the end of the explicit service period, the award is an equity-classified award that vests on the achievement of a performance condition. As such, for these employees, the grant-date fair value of the award is \$10 and compensation cost will be recognized over the employee requisite service period assuming the performance target is probable of achievement.

Performance Conditions Affecting Exercise Price

2.077 A performance condition may alter the exercise price of an award. In these circumstances, while the exact exercise price is not known at the grant date, the formula is known and agreed-upon by the parties.

2.078 Share options with performance conditions that affect the exercise price should be valued for each possible outcome of the condition. Attribution should be based on the entity's best estimate of the outcome of the condition. At the end of each reporting period, the facts and circumstances for achieving the performance target would be reassessed to determine if a different outcome is currently considered to be the best estimate. If so, the grant-date fair value for that outcome becomes the basis for recognizing compensation cost. ASC paragraphs 718-10-30-15 and 718-20-55-42 and 55-43

Example 2.6: Performance Condition Affecting Exercise Price

ABC Corp. issues 10,000 share options to its chief executive. The market price of the shares and the exercise price of the share options at the grant date are \$30. The share options have a performance condition whereby the exercise price is reduced to \$15 if the increase in ABC's sales exceeds 10% in each of the next three years.

ABC estimates the assumptions used in an option pricing model (i.e., share price, expected term, risk-free rate during the expected term, expected dividend rate, and expected volatility). It will then calculate a different grant-date fair value measure for each outcome that may occur (i.e., a grant-date fair value measure would be calculated using a \$15 exercise price and a second grant-date fair value measure would be calculated using a \$30 exercise price). In recognizing compensation cost, ABC estimates the likelihood of achieving the sales target. For example, if ABC believes at the grant date that the most likely outcome is that the increase in sales will exceed 15% in each of the next three years, the exercise price used to value the share options would be \$15, and the grant-date value of the share options would be \$16.26 (assumed for purposes of illustration). ABC would recognize compensation cost of \$54,200 in the first year (10,000 times \$16.26 divided by three years). However, if, in the second year, ABC believes the most likely outcome is that the increase in sales will exceed only 7% in each of the next three years, it would use the grant-date fair value of the share options using a \$30 exercise price (which means that all other inputs used in the option pricing model would be unchanged). Assuming that the change in the exercise price resulted in a grant-date fair value of \$10.45, ABC would recognize \$15,467 of compensation in Year 2, computed as follows:

| | |
|---|------------------|
| Remeasured grant-date fair value per share option | \$ 10.45 |
| Share options | 10,000 |
| Total compensation | \$ 104,500 |
| Proportion of service period completed | 2/3 |
| Cumulative compensation, end of Year 2 | \$ 69,667 |
| Compensation previously recognized | 54,200 |
| Compensation to recognize in Year 2 | <u>\$ 15,467</u> |

Market Conditions

2.079 A market condition is not regarded as a vesting condition. However, it is a condition that affects the exercisability, exercise price, or other pertinent factors used in determining the fair value of an award. Unlike a performance condition, however, a market condition relates to the achievement of a specified price of the issuer's shares or a specified amount of intrinsic value indexed solely to the issuer's shares or a specified price of the issuer's shares in terms of a similar (or index of similar) equity shares. For example, a share option award may contain a condition that the share option cannot be exercised until the entity's share price exceeds \$30 per share. A market condition *should* be considered in the estimate of the grant-date fair value of share-based payment awards (e.g., the probability of satisfying a market condition is considered in the estimation of the grant-date fair value), and it should not be an adjustment to the number of share options that vest for awards that are equity-classified. Unlike a service or performance vesting condition, for which compensation is reversed if the condition is not achieved, compensation is not reversed if a market condition is not achieved, provided the employee requisite service or nonemployee delivery of goods or services has been rendered. ASC paragraph 718-10-35-4

2.080 Some market conditions state that exercisability will be accelerated if the share price trades above a given target for a set time, e.g., if the share price trades above \$70 for 30 days. A market condition such as this creates a *path-dependent* share option, which results in greater complexity in valuing the share option. The value of such a share option does not depend solely on the intrinsic value at the end of the expected or contractual term, but also on share price paths prior to exercise.

2.081 Market conditions can also be tied to a market index, e.g., a share option becomes exercisable if the shares outperform the S&P 500 by a given percent over a stated period of time. This share option is more complex to value because, in addition to modeling share prices, one would need to model the market index to identify circumstances when the market condition would be met in order to determine when the share option would become exercisable.

2.081a A condition that is tied to the company's market capitalization may be a market condition when the market capitalization is calculated as share price times outstanding shares ($P \times Q$). If there are other elements of the condition that deviate from a company's market capitalization calculation, so that the condition is not solely $P \times Q$, then facts and circumstances (e.g., whether the condition relates to the achievement of a specified price of the issuer's shares vs. the achievement of a grantor's performance target) are considered to determine whether the condition is a market, performance, or other condition.

2.082 A random number generator or Monte Carlo simulation process can be used to generate stock price paths. The simulations can then be evaluated for paths when the market condition is reached and early exercise is possible. It is important that a large number of simulations be undertaken in order for the results to be relied upon.

2.083 It is important to note that the use of Monte Carlo simulation approaches to solve complex share option values makes it more difficult to exactly replicate a calculation. Such calculations are based on the generation of random numbers. Because the exact sequence of random numbers cannot be replicated, recalculations will not result in the exact same share option value. However, when the number of simulations is large, the average results of those recalculations should approximate those of the original calculation.

Example 2.7: Determining Fair Value for Share Options with a Market Condition

A company issues a share option to an employee with an exercise price of \$30, a contractual term of 10 years, and a four-year cliff-vesting service condition. To be exercisable, the share option also requires that the shares trade above \$40 for 10 consecutive days within four years of the grant. If that occurs, it also accelerates vesting. Expected volatility is 50%, the expected risk-free rate is 3%, and the expected dividend yield is 1%. The share price at the date of grant is \$30.

When applying a lattice model, the expected term of the model is not explicitly estimated (see Paragraph 2.063, fn 14). Instead, the use of expected postvesting termination and suboptimal exercise factors derive the expected term of the share option. For this example, the expected postvesting termination factor and the suboptimal exercise factor have been estimated at 5% per annum and two, respectively.

The entries below show the effect of introducing a market condition in this example. A condition that can accelerate exercisability reduces the expected term of the share option and, consequently, its value. In this example, the effect on fair value from introducing a market condition is as follows:

| | |
|--------------------------------|---------|
| Value without market condition | \$15.13 |
| Value with market condition | \$13.73 |

The market condition in this example accelerates vesting from what would otherwise be possible with the service condition. This earlier exercisability may result, as in this case, in earlier, sub-optimal, exercise of the award by the employee. (The recognition of compensation cost for an award that becomes exercisable when *either* a market *or* service condition is met is further described in Paragraph 4.111).

In other circumstances, where a market condition is required to be met for an award to become exercisable, the presence of the market condition causes a reduction in the value of the award, but for a different reason. In these cases, share options that are in-the-money but for which the market condition has not been met, will not be exercisable (in the example, the share options will become exercisable, even if the market condition is not met, provided the employee works for the four-year period of the service condition).

The median period in which the market condition is met would be the derived service period, and would constitute the requisite service period over which the compensation cost would be recognized. Assume that is determined to be 2.3 years. This period is not the expected term of the share option. However, other share paths in the valuation model can be used to determine expected term. Assume that the expected term of the share option without the market condition is 7.72 years and with the market condition is 5.8 years. (Because the calculations in this example are sensitive to the specific Monte Carlo simulations run to generate the share paths used to determine the fair value, the details of the calculation have not been included.)

A share option award that contains both a service and a market condition is valued as one share option with compensation cost recognized for the grant-date fair value amount. Therefore, compensation cost would be recognized using the \$13.73 grant-date fair value (value with the market condition).

Performance and Service Conditions That Affect Factors Other Than Vesting

2.084 Performance and service conditions or combinations thereof may affect factors other than vesting, such as exercise price, contractual term, quantity, or conversion ratio. For example, a share option might be granted with an exercise price of \$10, but the exercise price is reduced to \$8 if the company's growth in EPS during the vesting period outperforms the growth in EPS for a group of peer companies. Also, an award of nonvested share units may provide that the grantee will receive one share per share unit if the entity's market share exceeds 15%, but the grantee will receive 1.2 shares per share unit if the entity's market share exceeds 25%. A fair value should be established for each possible outcome of a service or performance condition and the final compensation cost will be based on the amount estimated at the grant date for the condition that is actually satisfied. ASC paragraph 718-10-30-15

Example 2.8: Employee Awards Where Performance Condition Affects Factors Other Than Vesting

ABC Corp. grants 10,000 share options to employees with an exercise price of \$30, a contractual term of 10 years, and a four-year cliff-vesting service condition. However, if ABC's average EPS for the four-year period exceeds \$5 per share, the exercise price is reduced to \$25. ABC uses the Black-Scholes-Merton model to estimate grant-date fair value for the share options. The grant-date fair value for each exercise price is:

| | |
|------------------------|-----------------------|
| Exercise price of \$30 | \$12 per share option |
| Exercise price of \$25 | \$15 per share option |

During Years 1, 2, and 3, ABC does not believe that it is probable that the EPS target will be achieved. As a consequence, ABC recognizes compensation cost based on the \$12 grant-date fair value measure during those years. In Year 4, it is determined that ABC will achieve the EPS target. As a result, the cumulative compensation cost is equal to the

grant-date fair value of the award using the \$25 exercise price. ABC would recognize compensation cost in each of the four years as follows.

Years 1, 2, 3 (expected exercise price of \$30, grant-date fair value of share options of \$12)

| | |
|--|------------|
| Total compensation cost (10,000 share options × \$12) | \$ 120,000 |
| Employee requisite service period | 4 years |
| Compensation cost per year | \$ 30,000 |

Year 4 (exercise price of \$25, grant-date fair value of share options of \$15)

| | |
|--|------------------|
| Total compensation cost (10,000 share options × \$15) | \$ 150,000 |
| Compensation cost recognized in Years 1 – 3 | 90,000 |
| Remaining compensation cost to recognize in Year 4 | \$ <u>60,000</u> |

Reload Features

2.085 Reload features allow a share option holder to automatically receive new share options when the original share options are exercised. While option pricing models have been developed to value share options with reload features, entities are required to value each award of share options separately based on its terms and the share price at the date on which each award is granted. As a result, subsequent awards granted under a reload provision are separately valued. Therefore, reload provisions are not included in determining the grant-date fair value of the original award. ASC paragraph 718-10-30-23

Clawback Features

2.086 A clawback feature is a provision in an award that requires the grantee in certain situations to return the share options, shares, or gains realized thereon either for no consideration or net of amounts paid by the grantee. Such features of an award are often triggered on departure in certain circumstances. Often for employee awards, the features are intended to prevent the employee from accepting employment with a direct competitor. As with reload features, clawback features are not considered in determining the grant-date fair value of the award. Rather, these features are accounted for if and when the contingent event occurs. While these features are not included in determining the grant-date fair value, they can impact the exercise behavior of the holder, which will influence the valuation assumptions. For example, an award with a reload feature may have a shorter expected term assumption than one without a reload feature if it is expected that the reload feature would influence the holder to exercise the award sooner. This would, in turn, result in a lower grant date fair value of the award. Therefore, an entity should consider the effects that a reload or clawback feature may have on the other relevant assumptions when developing the valuation. ASC paragraph 718-10-30-24

2.086a Some awards include in-substance clawback features, for example a repurchase feature with a repurchase price that is either equal to the cost of the shares or the lower of cost or fair value, in the event that the employee is terminated for cause. This kind of

repurchase feature serves as a protective clause that functions, in substance, as a clawback feature. It is a protective clause because it applies only if the employee is terminated for cause. Like clawback features, an in-substance clawback feature does not affect the classification of an award and is recognized only if and when the contingent event occurs.

2.087 Clawback features are accounted for if and when the contingent event occurs by recognizing the consideration received from the former grantee in the appropriate balance sheet account (treasury stock if the entity receives its shares) and a credit in the income statement. The amount of consideration recognized is equal to the lesser of the recognized compensation cost related to the share-based payment arrangement that contains the contingent feature or the fair value of the consideration received. See Paragraph 4.047 for discussion on discretionary clawbacks (discussion on the effect of SEC Exchange Act Rule 10D-1, implementing the Dodd-Frank Wall Street Reform and Consumer Protection Act, begins at Paragraph 4.045).

Example 2.9: Accounting for a Clawback Feature

On January 1, 20X5, when the market price of its shares is \$30 per share, ABC Corp. grants its CEO an award of 100,000 share options that vest on the completion of five years of service. The exercise price of the share option is \$30 and the grant-date fair value of each share option is estimated to be \$10. However, the award specifies that in the event of the employee's departure and subsequent employment by a direct competitor within three years after vesting, the share options, shares, or their cash equivalent on the date of employment by the direct competitor must be returned to ABC for no consideration to the former employee (a clawback feature).

Because the grant-date fair value of the award ignores the contingent clawback feature, the value at grant date would be \$1,000,000 ($100,000 \times \10).

Assume that the CEO's share options vest and within two years of vesting (but before any of the share options have been exercised), the CEO leaves ABC and is hired as an employee of a direct competitor of ABC. The former CEO is required to return the 100,000 share options. At the time the share options are returned, they have a fair value of \$1,700,000. At the date the award is *clawed back*, the following entry would be recorded to recognize the lesser of the recognized compensation cost (\$1,000,000) or the fair value of share options received as a result of the clawback feature (\$1,700,000):

| | Debit | Credit |
|----------------------------------|-----------|-----------|
| Paid-in-capital-share options | 1,000,000 | |
| Other income (compensation cost) | | 1,000,000 |

Example 2.10: Accounting for a Clawback Feature When the Value of Shares or Share Options Clawed Back Is Below the Compensation Cost

Assume the same facts as in Example 2.9, except that the value of the share options surrendered by the CEO is only \$600,000. At the date the award is *clawed back*, the following entry would be recorded to recognize the lesser of the recognized compensation cost (\$1,000,000) or the fair value of share options received as a result of the clawback feature (\$600,000).

| | Debit | Credit |
|--|-----------|---------|
| Paid-in-capital-share options ¹ | 1,000,000 | |
| Other income (compensation cost) | | 600,000 |
| Paid-in-capital surrender share options ¹ | | 400,000 |

¹ This example assumes that ABC maintains more than one paid-in-capital account in its accounting records. However, many entities report only one additional paid-in-capital account. In that situation, the entity would record a net debit of \$600,000 to additional paid-in-capital.

VALUING SEPARATE TRANCHES OF A GRADED AWARD

2.088 Share-based payment awards may have either cliff or graded vesting for employee awards. A cliff-vesting award vests in full at one point in time. For example, a share option award with a four-year cliff-vesting vests only, and in full, at the end of the four-year period. A graded vesting award vests gradually over time. An example of a four-year graded vesting award would be a share option award, which vests 25% after one year and on a monthly basis thereafter for the remaining 36 months. Because vesting indirectly affects the valuation of a share option through its effect on the expected term of the share option, the value of each separately vesting tranche of a graded vesting award will be different. As a result, a more representative valuation may be appropriate when each separately vesting tranche of an award with a graded vesting schedule is measured and recognized as a separate award. In addition to the impact on expected share option term, the other inputs to the option pricing model, such as expected volatility, expected risk-free rate, or expected dividends, may be different for the different expected terms of the award. However, the FASB recognized that requiring the multiple-award valuation method for all awards with graded vesting may be an unnecessary refinement, particularly where the use of average vesting period, expected term, etc. would yield a very similar result. As a result, ASC Topic 718 permits an entity to choose whether to recognize compensation cost for an employee award with service conditions that have a graded vesting schedule either (a) on a straight-line basis over the requisite service period for each separately vesting portion, or (b) on a straight-line basis over the requisite service period for the entire award. Paragraph 4.080 discusses graded vesting awards. ASC paragraph 718-10-35-8; Statement 123(R), par. B172

Q&A 2.11: Graded Vesting

Q. Consider a share option granted with an exercise price of \$30 and a contractual term of 10 years. The share price at the date of grant is \$30; the expected volatility is 50%, the risk-free rate is 3%, the expected dividend yield is 1%, the expected postvesting departure rate is 5%, and the suboptimal exercise factor is 1.5. What is the value of each vesting tranche of the award, if the share options vest 25% per year?

A. If the share option vests over four years, each vesting tranche of the award will have a different expected term. The grant-date fair value for each tranche in this example would be:

| | Vesting Period | | | |
|--------------------|----------------|---------|---------|---------|
| | 1 Year | 2 Years | 3 Years | 4 Years |
| Share option value | \$10.64 | 12.04 | 13.16 | 14.08 |

INABILITY TO VALUE COMPLEX SHARE OPTIONS

2.089 In rare circumstances, due to the terms of a share option, it may not be feasible to estimate the fair value of the award at the grant date. If the fair value of the instrument cannot be estimated at the grant date, it is measured at intrinsic value each period until it is settled, forfeited, or expires. The final measure of cumulative compensation cost will be the intrinsic value on the date it is settled. Even if fair value subsequently becomes known, the entity will continue to record compensation cost based on the share option's intrinsic value through settlement. ASC paragraph 718-20-35-1

2.090 We believe that it will be rare for public entities to be unable to estimate the fair value of an award.

ACCEPTABLE OPTION PRICING MODELS

2.091 Suitable option pricing models currently are categorized as lattice models, such as binomial; closed-form models, such as the Black-Scholes-Merton model; and simulations, such as Monte Carlo. Each uses similar assumptions.¹⁵ Software packages that include the Black-Scholes-Merton model and standard binomial option pricing models are available from various vendors. ASC Topic 718 acknowledges that more sophisticated models may be used in the future. As a result, the FASB did not require the use of a specific model but listed the characteristics of an acceptable valuation model and the assumptions that an acceptable model should consider.

Black-Scholes-Merton Model

2.092 The Black-Scholes-Merton model is a closed-form model that uses an equation to estimate the fair value of a share option. It values a share option by recognizing that the return on the share option can be replicated by creating a hedge portfolio based on an

underlying asset (the shares) and a risk-free bond. Because the share option can be hedged using this portfolio, use of the risk-free rate is appropriate. To the share option holder, the *payoff* is the share option's intrinsic value at exercise. However, because the share option is not exercised until a future point in time, the Black-Scholes-Merton model estimates the fair value of the share option as the present value of that future *payoff* based on the six inputs discussed beginning at Paragraph 2.012. Importantly, the Black-Scholes-Merton model can accommodate only one value for each of the six inputs.

Lattice Model

2.093 A lattice model values a share option by generating a lattice of future share prices, from which the share option value can be calculated. One benefit of a lattice model is that it can directly capture inputs such as suboptimal exercise and postvesting departure behaviors that can only be captured indirectly through the expected term assumption with the Black-Scholes-Merton model. Additionally, a lattice model can be adapted to incorporate the effects of market conditions on share option value. However, because a lattice model uses more inputs, it may not be possible to apply a lattice model in all situations because of a lack of available data.

2.094 To apply a lattice model, preparers need to gather information about early exercise behavior and analyze the data to identify early exercise drivers. Whether an entity's grantee exercise patterns provide meaningful information will depend on the entity's specific facts and circumstances. For example, a newly public entity may not be able to isolate meaningful early exercise drivers and would be unable to determine suboptimal exercise factors. Additionally, even those entities that can identify meaningful suboptimal exercise factors will need to update the information on an ongoing basis. This may require changes to the assumptions used by an entity as exercise behaviors change. When an entity lacks sufficient internal data to apply a lattice model, information about economy-wide early exercise behavior may become available over time. However, the ability to apply external data to an entity's analysis would require a careful evaluation of the source, integrity, and nature of external data and its fit to the entity's specific circumstances. As behavior is likely to change by industry, age, rank, income level, and other factors, the application of externally sourced assumptions may be limited.

2.095 An entity may have a common provision in its employee share option grants that, upon departure from the entity, an employee has a limited period of time (e.g., 30-90 days) to exercise his or her vested share options. In addition to employee early exercise behaviors, entities with such provisions would need to gather and analyze employee postvesting departure information to apply a lattice model.

2.096 The FASB identified several other factors that influence employees' early exercise decisions: employee age, length of service at the entity, the employee's home jurisdiction (foreign or domestic), and the evolution of the stock price during the share option's expected term. The first three factors would likely not be directly considered in the valuation model. Instead, they would be considered when grouping employees into categories to identify share option exercise behavior. (ASC paragraph 718-10-S99-1 suggests that as few as one or two groupings may be sufficient in certain circumstances to

make reasonable fair value estimates.) For the fourth factor, because a lattice model develops stock price paths over the share option's contractual term, exercise behavior based on the evolution of the stock price can be directly considered in the valuation. This would not be possible using a Black-Scholes-Merton model.

Applying a Lattice Model

2.097 In this section, we discuss the application of a lattice model. Broadly speaking, a lattice model builds a tree of possible future share price paths and uses this tree to value the share option. At points in the share-price tree when exercise is assumed, the intrinsic value of the share option, i.e., the net cash flow at exercise is discounted back to its present value at the grant date. Therefore, a lattice model is, like the Black-Scholes-Merton model, a discounted cash flow model.

2.098 A lattice model uses:

- A *share-price* tree representing possible future share prices from the grant date until share option expiration. Each point on the tree is referred to as a node. Nodes that represent the share price at the share option's expiration are called terminal nodes.
- The share options are valued based on the share-price tree. These intrinsic values at exercise nodes are worked back through the *share option-pricing* tree to the grant date, by probability weighting and present valuing the amounts.

2.099 An entity applying a lattice model should, at a minimum, incorporate the six factors required by ASC Topic 718 and may be able to further refine those factors based on the features of the lattice model. See discussion beginning at Paragraph 2.010 for the six factors required by ASC Topic 718. The six factors affect different aspects of the model. The share price at grant date, the expected volatility of the shares, and the expected dividends are used in creating the *share-price* tree. The exercise price and the expected share option term are used in the *share option-price* tree. The expected risk-free rate affects both the share-price tree and the share option-price tree.

2.100 A lattice model can explicitly consider early exercise behavior by incorporating additional inputs beyond those that can be included in the Black-Scholes-Merton model. These additional inputs and their effect on the valuation are briefly described below.

SUBOPTIMAL EXERCISE FACTOR

2.101 Exercise is the only way a grantee can obtain liquidity from a share option because the grantee cannot sell a share option in the market. Several studies have found that share options tend to be exercised when the share price reaches a specific multiple of the exercise price. A lattice model can be created that assumes share option exercise when the share price reaches a predetermined multiple of the exercise price. ASC Topic 718 calls this *suboptimal exercise* because the share option would be worth more if the grantee continued to hold it. Because this factor can have a significant effect on the share

option value, it is important that entities develop appropriate assumptions of the suboptimal exercise factor and other early exercise algorithms based on actual exercise experience. It would not be appropriate for an entity to rely on general estimates or macroeconomic studies as the basis for its assumption about the suboptimal exercise factor. Because grantee behavior differs depending on factors such as age, income level, family status, and other demographics, an entity may stratify its grantees into various demographic categories and develop separate suboptimal exercise factors for each stratum. ASC paragraph 718-10-S99-1 suggests that as few as one or two groupings may be sufficient in certain circumstances to make reasonable fair value estimates.

POSTVESTING DEPARTURE RATE

2.102 Another reason employees may exercise vested share options before expiration is because they have been terminated or are otherwise separating employment from the entity. Many share option plans contain a provision requiring an employee who departs to exercise vested share options within a short period of time, such as 90 days. Vested share options that are in-the-money will be exercised while vested share options that are out-of-the-money will not. Therefore, the postvesting departure rate will affect the lattice model's treatment of the expected term and, therefore, affect the share option's value.

BUILDING A SHARE-PRICE TREE

2.103 A lattice share-price tree is based on the concept that during each interval of time, the share price can make only two possible movements, up by a factor- u , or down by a factor- d . Thus, at each node starting with the share price on the grant date, the share price branches up and down, representing the range of up and down price movements. The model generates the range of share prices using the assumptions of expected volatility, expected risk-free rate, and expected dividends, which are applied to the share price over the term of the share option.

2.104 The process of building a binomial share-price tree is illustrated below over two periods for a share with a share price designated S .

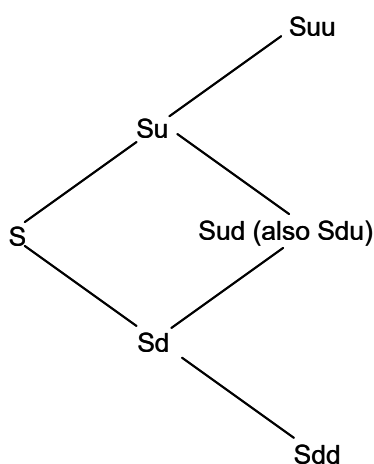

2.105 Repeating this process through intervals of time from the grant date to the expiration date creates a tree of possible share prices.

2.106 The probabilities of the share price reaching various prices on the tree differ. Outlier share prices (those either very high or very low) are less likely to occur than are mid-range prices. In addition, unlike a coin toss, the probability of an up or down price movement may not be equal.

2.107 The lattice model assumes that share prices will increase on a probability-weighted average basis at the expected risk-free rate less the expected dividend rate. Dividends reduce share prices because, in economic theory, an entity's market value is reduced by the amount of its dividend payments. The model uses the expected risk-free rate rather than the expected return on the shares because the share option payoff can be hedged using a portfolio of the underlying share and a risk-free bond.

VALUING THE SHARE OPTIONS

2.108 Share options are valued based on the intrinsic value of the share option at the terminal nodes in the share-price tree, unless early exercise is assumed. Share options, which are out-of-the-money at expiration have a value of zero, while in-the-money share options have a value at expiration equal to their intrinsic value. The amounts at the terminal nodes are present-valued back to the grant date using the expected risk-free rate and probability weighting the outcomes, starting at the terminal nodes and working back to the grant-date node.

2.109 Entities applying a lattice model should also consider suboptimal exercise and postvesting departures. In a lattice model, the share option-value tree can be programmed to monitor the share-price tree to identify nodes at which the share price reaches a multiple of the exercise price (suboptimal exercise factor). The share option-value tree can also consider early exercise based on a probability of departure at each node after vesting.

2.110 Dividends also can influence early exercise behavior. On dividend-paying shares, the share option holder might early exercise the share option to secure the dividend and to offset a reduction in the share price from the dividends. A lattice model can be programmed to identify these early exercise behaviors as well.

EXPECTED TERM

2.111 Because a lattice model can directly incorporate early exercise behaviors, such as suboptimal exercise, postvesting departures, and the effect of dividends, into the option pricing model, the expected term of a share option can be calculated from the *output* of a lattice model. For the Black-Scholes-Merton model, expected term is an *input*. To the extent that an entity has captured the effect of early exercise behaviors in its assumption of expected term, the expected term output from a lattice model should closely approximate the expected term input used in the Black-Scholes-Merton model.

Relationship of Lattice Model Results to Black-Scholes-Merton Model Results

2.112 A lattice model will not automatically result in share option values that are lower than those calculated using the Black-Scholes-Merton model. A lattice model is based on the same six input assumptions as the Black-Scholes-Merton model. Because a lattice model can directly capture early exercise behaviors while the Black-Scholes-Merton model approximates these behaviors through the expected term input, differences can arise if the expected term assumption in the Black-Scholes-Merton model does not adequately approximate the effect of early exercise behavior.

2.113 Likewise, the Black-Scholes-Merton model uses a single input for expected risk-free rate, expected volatility, and expected dividends, while a lattice model can accommodate different inputs for these variables at different points in time. Again, to the extent that the *average* of these inputs in a lattice model closely approximates the inputs used in the Black-Scholes-Merton model, the models should yield substantially similar results.

2.114 Thus, the differences in values determined using different option pricing models depends on the interaction among the six factors and how well an entity's previous estimates of expected term, expected risk-free rate, expected volatility, and expected dividends captured these interactions. Therefore, one should not expect that a lattice model would always result in a lower share option value than would the Black-Scholes-Merton model.

Changing to a Lattice Model

2.115 ASC Topic 718 does not require the use of a specific model, but does require that the model chosen should take into account the instrument's specific characteristics. Accordingly, an entity should identify the specific characteristics of its instruments and consider how its valuation model takes those characteristics into account. Black-Scholes-Merton does not readily incorporate certain characteristics, for example, market conditions.

2.116 An entity is not required to continue to use a specific model. ASC Topic 718 states that an entity should change the valuation technique it uses to estimate fair value if it concludes that a different technique is likely to result in a better estimate of fair value. For example, an entity that uses a Black-Scholes-Merton model might conclude, when information becomes available, that a binomial model or another valuation technique would provide a fair value estimate that better achieves the fair value measurement objective and, therefore, change the valuation technique it uses. The FASB believes that the lattice model more fully reflects the substantive characteristics of employee share options and similar instruments granted in share-based payment transactions. As a result, if an entity has concluded that it has the information needed to apply a lattice model, that may be a more appropriate model.

2.117 ASC Topic 718 indicates that the valuation technique an entity selects to estimate fair value for a particular type of instrument should be used consistently and should not be changed unless a different valuation technique is expected to produce a better estimate of fair value. A change in either the valuation technique or the method of determining appropriate assumptions used in a valuation technique should be applied prospectively to subsequently granted awards or to subsequent remeasurements of liability-classified awards. ASC paragraph 718-10-S99-1 also permits an entity to change from one valuation technique to another without obtaining a preferability letter from its independent accountant because this is deemed to be a change in estimate. However, the SEC staff expects changes in valuation techniques to occur infrequently.

2.118 ASC Topic 718 allows the use of different valuation techniques for instruments with different substantive characteristics. The Black-Scholes-Merton model may be acceptable for valuing many awards. However, because the valuation technique employed should reflect all the substantive characteristics of an instrument, except those explicitly excluded, such as vesting conditions or reload or clawback provisions, the Black-Scholes-Merton model may not be suitable for all awards. For example, an entity may issue *plain vanilla* share options that might be valued using the Black-Scholes-Merton model. However, it might also issue share options or similar instruments granted in share-based payment transactions with a market condition that may need to be valued using a lattice model or a Monte Carlo simulation technique. ASC paragraph 718-10-55-17

2.119 ASC paragraph 718-10-S99-1 states that an entity is not required to use a lattice model except for instruments that cannot be valued by a Black-Scholes-Merton model, such as share options that contain a market condition. Although a lattice model has greater flexibility and may be better able to value some share options, assuming that it has reliable assumptions, some entities have found it difficult to identify reliable model inputs that are needed to apply the lattice model. An entity that is able to develop different valuation models is not required to pick the most complex method and the SEC staff has indicated that they will not object to an entity's choice of model, provided it meets the fair value measurement objective. Notwithstanding, an entity should not base its choice of model solely on achieving a lower estimated fair value.

2.120 If an entity that previously has used a closed-form model, such as Black-Scholes-Merton, to determine the fair value of its awards, uses a lattice model to determine fair value of an award, it generally would be required to use the lattice model for valuing future grants of awards and for subsequent remeasurements of liability-classified awards. In any event, grant-date fair value for previously granted equity-classified awards should not be recalculated.

2.121 There are, however, situations in which the use of a lattice model or a simulation may be necessary and its use would not result in a requirement to use a lattice model or a simulation for other awards. For example, out-of-the-money awards may contain an implicit market condition (see Paragraph 4.059). For those awards an entity generally needs to determine the fair value of the awards using a lattice model or a simulation. In addition, use of a lattice model or simulation may be necessary to determine fair value of

awards before and after a modification to determine the incremental compensation cost. For example, if out-of-the-money awards are modified to reduce the exercise price or are exchanged for a lesser number of at-the-money awards with equivalent fair value, a lattice model or simulation generally would be used to determine the fair value of the original awards immediately before the modification. Using a lattice model or simulation to determine the fair value of the awards after the modification also is recommended and an entity should use the same processes and level of rigor in developing assumptions about the inputs to lattice models or simulation for both the *before* and *after* fair value determination. Using a lattice model for both awards generally results in a better measure of incremental compensation cost because the fair value of both awards is determined using the same methodology. It also is consistent with the measurement objective for modified awards: to compute the incremental compensation cost, which differs to some degree from the measurement objective for awards at the date of grant.

2.122 When an entity using the Black-Scholes-Merton model begins to gather early exercise and other data to apply a lattice model, the data gathered may not provide meaningful information on grantee behavior. For example, when an entity is newly public, its share option exercise history may not provide reliable early exercise relationships. In these circumstances, an entity may gather exercise information for several years before it concludes that sufficient information is available to identify reliable early exercise predictors. If, at that point, the entity chooses to adopt a lattice model, it would constitute a change in accounting estimate, not a change in accounting principle.

Q&A 2.12: Changing to a Lattice Model

Q. ABC Corp. has been studying a lattice model and management believes that it is better suited to valuing ABC's share option grants than its current option pricing model, the Black-Scholes-Merton model. ABC begins to gather share option exercise data to support early exercise assumptions to incorporate in a lattice model. Upon gathering and analyzing sufficient information, ABC wishes to begin using a lattice model to value its share option grants. In this circumstance, is it appropriate for ABC to change to a lattice model?

A. Yes. While the valuation technique that an entity selects to estimate the fair value of a particular type of instrument should be used consistently, a change to a different valuation technique that is expected to produce a better estimate of fair value is acceptable. If an entity that uses a closed-form model concludes that a lattice model or another valuation technique would provide a fair value estimate that better achieves the fair value measurement objective, the entity could appropriately change the valuation technique it uses. Because ABC believes that the lattice model will result in a better estimate of fair value, a switch in valuation technique is appropriate.

A change in either the valuation technique or the method of determining appropriate assumptions used in a valuation technique is a change in accounting estimate, not a change in accounting principle, for purposes of applying ASC Subtopic 250-10, and

should be applied prospectively to newly granted awards and to subsequent remeasurements of liability-classified awards. Accordingly, such a change does not require a preferability letter from the entity's independent registered public accountant. See KPMG Handbook, Accounting changes and error corrections, Questions 3.2.50 and 6.2.20.

Illustration of a Lattice Model

2.123 The following example provides an illustration of how a lattice model is applied.

Example 2.11: A Lattice Model Approach

Consider a share option on a share with an exercise price of \$10 and a term of four years. The remaining variables are a current share price (S) of \$10, an expected volatility rate (σ) of 50%, a continuously compounded expected risk-free rate (r) of 5.83%, which is equivalent to an expected annual rate of 6%, and a zero dividend yield. For simplicity, the example uses only four calculation periods, that is, only one calculation period (Δt) per year.

One formula for the upward share price movement, using the share price's volatility, where e is a mathematical factor to calculate continuous compounding, is:

$$u = e^{\sigma\sqrt{\Delta t}}$$

The downward movement is set to allow the tree to recombine (i.e., $S_{ud} = S_{du}$) so that:

$$d = 1/u$$

For each node, the probability of an up movement (p) and a down movement ($1-p$) is calculated as:

$$p = \frac{e^{r\Delta t} - d}{u - d}$$

Using the above formulae and inputs, the values of u , d , and p are:

$$u = e^{\sigma\sqrt{\Delta t}} = e^{0.5 \times \sqrt{1}} = 1.6487$$

$$d = 1 / u = 1 / 1.6487 = 0.6065$$

$$p = \frac{e^{r\Delta t} - d}{u - d} = \frac{e^{0.0583 \times 1} - 0.6065}{1.6487 - 0.6065} = 0.4351$$

The Share-Price Tree. The following share-price tree is constructed using the current share price and the amounts for u and d .

The period 1 share prices of \$16.49 and \$6.07 were developed as follows: the price of \$16.49 was derived from the grant-date share price multiplied by u , which is $\$10 \times 1.6487$, and the price of \$6.07 was derived from the grant-date share price multiplied by d , which is $\$10 \times 0.6065$. In period 2, the price of \$27.18 is calculated as \$16.49 multiplied by 1.6487, which represents two up-movements in the share price; the price of \$10 represents either \$16.49 multiplied by 0.6065 or \$6.07 multiplied by 1.6487, which represents the result of an up-movement followed by a down-movement or vice versa; and the price of \$3.68 represents \$6.07 times 0.6065, which represents the result of two down-movements. The fact that an up-movement followed by a down-movement is the same as a down-movement followed by an up-movement means that the tree is said to recombine.

Intrinsic Value at Expiration Nodes. The intrinsic value of the share option at each terminal node is the amount the share price at that node exceeds the share option's exercise price. If the share price at the terminal node is less than the exercise price, there is no positive cash flow to the share option holder and the share option would expire unexercised.

Thus, the share price is \$73.89 for the terminal node at the highest point in the tree above, so the intrinsic value of the share option at that node is \$63.89 ($\$73.89 - \10). The share price is \$1.35 at the terminal node at the lowest point in the tree, so the intrinsic value of the share option at that node is zero.

Calculate the Value of the Share Option. The intrinsic value at each terminal node is present-valued back to the nodes for each prior period until reaching the grant-date node.

At a given node, the value of a share option exercisable only at expiration (Ct-1) is derived from the probability-weighted average discounted value of nodes created by branching in the immediately succeeding period (Ct). Mathematically stated:

The value at the highest node in the third period is equal to the probability-weighted, discounted values at the two terminal nodes that branch from that third-period node. From the above formula, the value at the highest node in the third period would be:

$$0.4351 \times \$63.89 \times e^{-.0583 \times 1} + (1 - 0.4351) \times \$17.18 \times e^{-.0583 \times 1} = \$35.38$$

Completing this calculation for all nodes, and ignoring suboptimal exercise factors for the moment, moving from right to left, yields the share option value at grant date of \$4.35, as shown below.

| | 0 | 1 | 2 | 3 | 4 |
|------|---|------|------|------|------|
| | | | | | 63.8 |
| | | | | 35.3 | |
| | | | 18.2 | | 17.1 |
| | | 9.05 | | 7.05 | |
| 4.35 | | | 2.90 | | 0.00 |
| | | 1.19 | | 0.00 | |
| | | | 0.00 | | - |
| | | | | - | |
| | | | | | - |

Increasing the number of nodes improves the reliability of the results.

Early Exercise Behavior. Assume that detailed modeling of the company’s exercise history shows that the grantees traditionally exercise their share options when the share price reaches twice the exercise price (a suboptimal exercise factor of two). One would then assume that the share options would be exercised when the share price reaches \$27.18 on the share-price tree (the highest node in period 2), which is the first point on the share-price tree where the share price is greater than or equal to \$20 or twice the exercise price. The intrinsic value at this node of \$17.18 (\$27.18 - \$10) would then be subjected to probability-weighted present valuing to arrive at the share option value at the grant date. In this example, *other things being equal*, this would lower the value of the share option to \$4.16, as shown below:

The stock price at the equivalent node in the stock-price tree is \$27.18, well above the exercise level historically experienced by the company. The model therefore assumes exercise at this node and the intrinsic value is \$17.18 (\$27.18 – \$10).

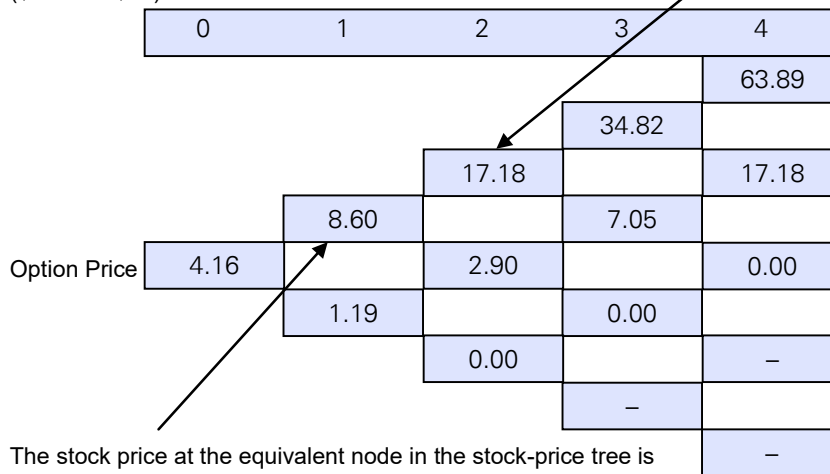

The stock price at the equivalent node in the stock-price tree is \$16.49. The model does not assume early exercise. This value is therefore based on the discounted, probability-weighted value of the related successor-period nodes, \$17.18 and \$2.90.

This *suboptimal behavior* (i.e., by early exercising of the share option, the grantee is giving up its remaining time value) has been consistently observed and is discussed in ASC paragraph 718-10-55-29. A key driver of this behavior is the lack of transferability and the absence of a ready market for these instruments. As a result, a grantee who wants liquidity, for example, to *lock-in* gains, to diversify the investment holdings, to purchase a house, or to pay for college, is unable to sell the share options and, therefore, must exercise the share options to monetize the amounts.

Postvesting Termination. The valuation tree above was calculated without considering the likelihood of postvesting departures and assuming vesting at the end of period 1. Assume that the company estimates the postvesting departure rate of 5% per year and, upon departure, the share option holder has 90 days to exercise the share option. Also assume that the first date that departure can occur is at the end of period 1. The effect of postvesting terminations on the share option value is illustrated below:

| Period | 0 | 1 | 2 | 3 | 4 |
|---|------|------|-------|-------|-------|
| | | | | | 63.89 |
| | | | 18.20 | 35.35 | 17.18 |
| | | 8.81 | 7.02 | | |
| Option Price | 4.19 | | 2.74 | | 0.00 |
| | | 1.07 | 0.00 | | |
| | | | 0.00 | | - |
| <p>The employee has a 5 percent likelihood of leaving. If they leave, they will realize the intrinsic value at this point, i.e. \$16.49 less \$10.00, i.e. \$6.49. If the employee does not terminate (a 95 percent likelihood), the value will be based on a probability weighted discounted terminal values, i.e. \$17.18 x .43511 x .9434 and \$0 x .5649 x .9434, i.e. \$7.05. Five percent of \$6.49 and 95 percent of \$7.05 yields \$7.02.</p> | | | | | |

A lattice model uses the contractual term coupled with assumptions of early-exercise behavior to estimate the expected term of the share option, whereas the Black-Scholes-Merton model requires that the expected term be estimated as an input to the model. Whether the values resulting from a lattice model are more reliable estimates of fair value than those resulting from the Black-Scholes-Merton model depends on the quality of the underlying assumptions used as inputs to the respective models, particularly whether the assumptions of suboptimal exercise and postvesting terminations are reliable predictors of early exercise behavior by the grantees. Because a lattice model allows for greater flexibility, it can be used to value more complex awards, for which extension of a closed-form model is extremely difficult.

Use of Monte Carlo Simulation

2.124 A Monte Carlo simulation uses random numbers, together with the assumption of volatility, to generate individual stock price paths. This approach can be very useful for valuing an award with a market condition because each individual stock price path that is generated can be monitored to identify paths where the market condition is met. The simulation process can be repeated numerous times to generate numerous different stock-price paths. Because each simulation is based on a different random number, it will have its own unique path.

2.125 In general, there are two principal methods used to generate a stock price path when using Monte Carlo simulation:

- Using lattice model parameters, or
- Directly modeling stock price return and volatility.

2.126 In the first approach, the stock price path is generated using the lattice model formula, that is, at any given price point, the stock price is assumed to either increase by the lattice model up-factor or decrease by the lattice model down-factor, depending on the random number generated at that point on the path. When using these factors in a

Monte Carlo simulation, the random number generated is between 0 and 1. When the random number generated is less than the probability of the up-factor, p , the current stock price is multiplied by the up-factor. When the random number generated is greater than the probability of the up-factor, p , the current stock price is multiplied by the down-factor. By repeating this process, a single stock price path is created, which can be used to determine when or whether a market condition is achieved. The results can be averaged over many observations.

2.127 For example, assume the stock price on the date of grant is \$100, and the up-factor, down-factor, and associated probabilities are 1.02, 0.99, 0.65, and 0.35, respectively (note the probability of the up and down probabilities will sum to one). If the first random number generated is 0.40, which is less than the up-factor probability of 0.65, an up movement is assumed and the stock would increase to \$102. If the second random number generated is 0.82, then a down movement is assumed and the stock would move to \$100.98. This process would be continued to the terminal node with the process being repeated numerous times.

2.128 Alternatively, one can generate a factor to be applied against the stock price (S_n) to arrive at the subsequent stock price (S_{n+1}). This factor not only has a deterministic component and a stochastic component, which reflects the assumption that the stock is expected to increase at a known rate or *drift*, but also a random component related to its volatility that causes the actual outcome to differ from the drift. By repeating this process, a single stock price path is generated, from which the share price can be monitored to see when, or whether a market condition is achieved. Again, the results can be averaged over numerous simulations.

2.129 An example formula may include the following

$$\left(\mu - \frac{\sigma^2}{2}\right)\Delta t + \varepsilon\sigma\sqrt{\Delta t}$$

where:

- μ is the rate of return or drift.
- σ is the standard deviation.
- Δt is the length of time between stock price movements.
- ε is a random number.

2.130 The following graph illustrates 10 stock price paths generated over 50 days, using a Monte Carlo simulation.

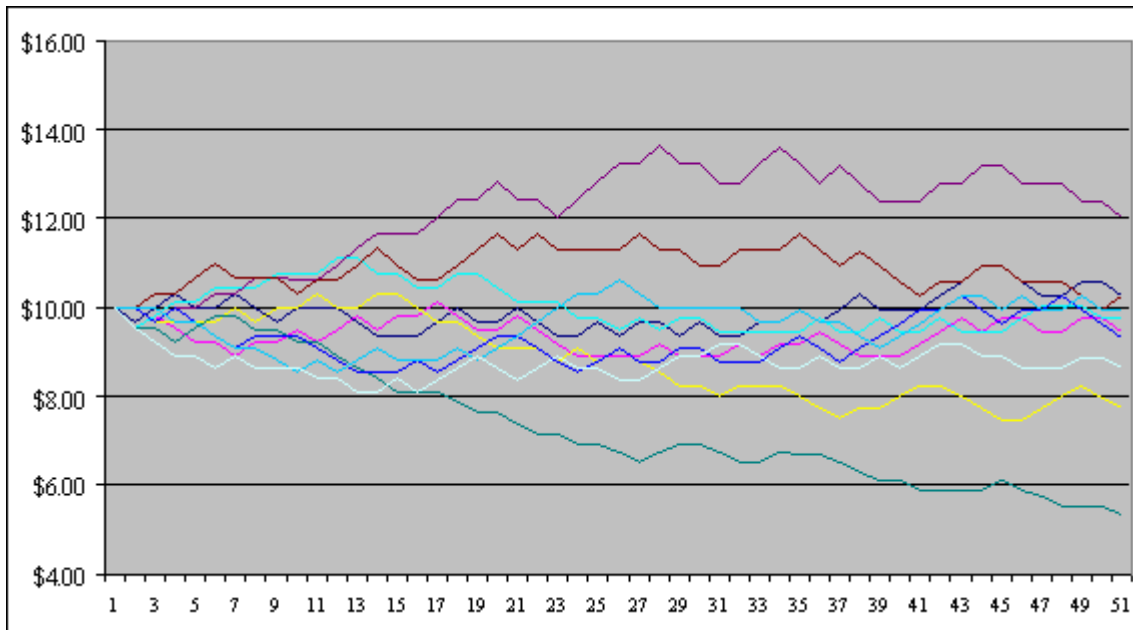

2.131 The share price derived from each of the 10 Monte Carlo simulated paths is monitored to determine when, or whether, the market condition is achieved. One example of a market condition is that the future stock price must hit a certain threshold or total shareholder return over a performance period. The graph shows the outcome of the simulated future stock price paths for a typical simulation model. Each path in the simulation graph represents simulated future stock prices over the performance period. For each simulated stock price path in which the market condition is achieved, the simulated future stock based payout (e.g., multiples of future stock values for restricted stock units or intrinsic value for options) is then discounted back to the valuation date to determine the present value of the payout for that path. The grant-date fair value of the award is calculated as an average of the present values over all simulation paths, including the paths for which the market condition is not achieved (those paths would have a payout of \$0). A Monte Carlo simulation model often uses 100,000 or more simulation paths to estimate the grant-date fair value of an award.

VALUING SHARES

Valuing Nonvested Shares

2.132 Many entities grant *nonvested* shares or share units. While such grants have typically been referred to in practice as *restricted shares*, ASC Topic 718 refers to these grants as *nonvested shares*. ASC Topic 718 requires that nonvested shares be valued at the fair value of the shares on the date of grant if vesting is based on a service or a performance condition. Because grant-date fair value does not reflect restrictions during the vesting period, for an entity that has publicly traded shares, the grant-date fair value of a nonvested share would be the market price of the share on the grant date. Deductions from the share price should not be made for transferability restrictions during the vesting period. However, if a nonvested share grant vests *only* on the occurrence of a market

condition, it would be appropriate to adjust the current market price of the stock to reflect the effect of the market condition on the nonvested shares' value. When observable market prices do not exist for the shares, valuation techniques should be used to value the shares. See additional discussion of valuation of shares of a nonpublic entity beginning at Paragraph 2.159.

2.133 ASC Topic 718 specifies that factors related to vesting are not reflected in the determination of grant-date fair value of a share-based payment award. Consequently, nonvested shares would be valued at the fair value of the entity's shares on the date of grant if vesting is based on satisfaction of a service or performance condition, because there would be no adjustment to the market price of the stock for the vesting provisions (service or performance).

2.134 As described beginning at Paragraph 2.079, a market condition is reflected in the grant-date fair value measure because a market condition is considered to be an exercisability condition rather than a vesting condition. As a consequence, for a nonvested share award that is exercisable only on the achievement of a market condition (e.g., the achievement of a share price target), the market price of the entity's stock would be adjusted to reflect the market condition in determining the grant-date fair value of the award. Therefore, a grant of nonvested shares that becomes nonforfeitable only on the achievement of a market condition would have a grant-date fair value that is less than the market price of the entity's stock on the date of grant.

2.135 If an entity grants nonvested shares that vest on the occurrence of either a market condition or a service or performance condition, the nonvested shares would be valued based on the fair value of the shares at the date of grant because the employee can earn the award by satisfying the service or performance condition. As a result, the market condition does not affect the grant-date fair value of the award.

2.136 If an entity grants nonvested shares that vest on the occurrence of a market condition *and* a service or performance condition, the fair value of the nonvested shares would be adjusted to reflect the effect of the market condition on the nonvested shares' value because the achievement of the market condition in addition to the service or performance condition is necessary for the awards to become nonforfeitable.

2.136a Paragraph 2.161a discusses a practical expedient available to nonpublic entities for valuing the share price.

Treatment of Dividends Payable on Shares during the Vesting Period

2.137 Depending on the terms of the award, the holder of an award of nonvested shares may or may not be entitled to dividends declared on the shares during the vesting period. When the holder is *not* entitled to dividends during the vesting period, the value of the nonvested shares should be reduced by the present value of the expected dividend stream during the vesting period using the risk-free interest rate. Statement 123(R), par. B93

Q&A 2.13: Valuation of Nonvested Shares Depending on Whether the Holder Is Entitled to Dividends in the Vesting Period

Scenario A

Q. ABC Corp. grants 100,000 shares to four members of senior management. The share price was \$100 at the grant date. The shares are subject to a four-year cliff-vesting service condition. Management is entitled to receive dividends on the shares during the vesting period. There are no postvesting restrictions on selling the shares. What value per share should be used in computing compensation cost?

A. The fair value of the award is not adjusted for restrictions due to vesting or the value of any expected dividends. As such, the fair value of the shares, \$100 per share, would be used in computing compensation cost.

Scenario B

Q. ABC Corp. grants 100,000 shares to four nonemployee consultants that provide services to the company over a four-year period. The share price was \$100 at the grant date. Grantees are not entitled to dividends on the shares during the vesting period. Annual dividends are expected to be \$2.50 (paid quarterly) during the vesting period. The dividends, as a dollar amount, are not expected to change during the vesting period. There are no postvesting restrictions on the grantees' ability to sell the shares. What value per share should be used in computing compensation cost?

A. In estimating the fair value of the award, the share price of \$100 per share would be reduced by the present value of the dividends that will not be received during the vesting period, using the risk-free rate. Assuming a risk-free interest rate of 4% with quarterly compounding, the present value of the dividends foregone during the vesting period is \$9.20. This amount would be deducted from the \$100 share price of the shares to arrive at the value of the award of \$90.80 (\$100 - \$9.20) per share.

Valuing Restricted Shares

2.138 ASC Topic 718 uses the term *restricted share* to refer to shares for which sale is contractually or governmentally *prohibited* for a specified period of time after vesting. These are distinguished from nonvested shares, whose limitation on sale stems solely from the forfeitability of the shares before grantees have satisfied the necessary vesting conditions to earn the rights to the shares. Additionally, we believe ASC Topic 718 distinguishes between restrictions that prohibit the sale of shares versus those that limit the sale of shares. Therefore, shares subject to sale limitations (e.g., securities issued pursuant to Rule 144A) do *not* constitute restricted shares.

2.138a When restricted shares are issued, a deduction from the observable market price of an unrestricted share may be appropriate for the postvesting restriction period. Determining what restrictions should be incorporated into the valuation requires

judgment. In a 2007 speech, an SEC staff member observed that “we have also seen instances in which assumptions related to a specific holder attribute were incorporated in the valuation of share-based payments. While the determination of which assumptions to incorporate is judgmental, we believe that it would be difficult to substantiate that assumptions that reflect an attribute of a specific holder versus a market participant would be appropriate. Statement 123(R) specifies that the assumptions should reflect information available to form the basis for an amount at which the instrument being valued would be exchanged, and that the assumptions used should not represent the biases of a particular party.” Therefore, we believe that generally only restrictions that are attributes of the share (i.e., security-specific) should be incorporated in the valuation versus attributes of the holder.

2.138b Any discounts for security-specific postvesting restrictions should be consistent with those observed in similar transactions with third parties if the information is available. Any such discounts should consider the nature and term of the restriction, the volatility of unrestricted shares, and the risk-free rate. The discounts should be closely scrutinized and should be properly supported. ASC paragraph 718-10-30-10

2.139 It is expected that the discount from market share prices for security-specific restrictions would be limited. This is because the ongoing cost to an entity of a restricted share is very similar to the cost of an unrestricted share (although a restricted share may have somewhat lower issuance costs and may be issued more quickly). In addition, while restrictions may be burdensome to a specific holder, they are likely to be less important to longer-term investors. The method used to estimate these discounts should be objective and reliable.

2.140 When valuing a share option or similar instrument, it may be appropriate to apply a discount to the share price input used in the option pricing model to reflect the effect of postvesting security-specific restrictions on the stock into which the share option will be exercised. However, it is inappropriate to apply an additional discount to the value of the share option calculated by the model to reflect nontransferability. The nontransferability of the share option is considered through the effect of early exercise behaviors on the expected term of the share option and is not considered by applying a discount to the value calculated by the option pricing model.

Illiquidity Discounts

2.141 As discussed in Paragraph 2.138 above, certain postvesting security-specific restrictions are included in the grant-date fair value measurement. These security-specific restrictions are reflected in the valuation through an illiquidity discount (also sometimes referred to as a discount for lack of marketability or DLOM).

2.141a In a 2015 speech, an SEC staff member observed that some entities have indicated that postvesting holding restrictions on share-based payment awards can result in significantly lower stock compensation cost. While postvesting security-specific restrictions should be considered in estimating the fair value of share-based payments, the guidance in ASC 718-10-55-5, which states in part that “...if shares are traded in an

active market, postvesting restrictions may have little, if any, effect on the amount at which the shares being valued would be exchanged” should be considered. While it is appropriate to incorporate an *illiquidity discount* into the valuation for postvesting security-specific restrictions, entities should have support for the amount of the discount rather than relying on subjective estimates or broad-based academic studies.¹⁶ The SEC staff would expect the discount used to determine the fair value of the share-based payment award to be based on market participant considerations related to the underlying award, rather than attributes related to the specific employee.

2.141b There are different methods that valuation professionals typically propose to determine the discount used to determine the fair value of the share-based payment award. Several of those methods are described in this section.

PROTECTIVE PUT MODELS

2.142 While certain applications of put option models may yield a satisfactory estimate of the illiquidity discount, use of stand-alone put models (e.g., a European put) tends to overstate the amount of the illiquidity discount. Typically, the model is based on an at-the-money put option (i.e., strike price is equal to the current price of the stock), which is used to develop the premium required to protect against downside price risk over the term of the restriction. The premium divided by the current stock price is used as the measurement of the illiquidity discount.

2.143 The overstatement of discount that this technique generates can be seen by comparing the graph of possible outcomes of an unrestricted share with the graph of possible outcomes of a restricted share plus an at-the-money put option.

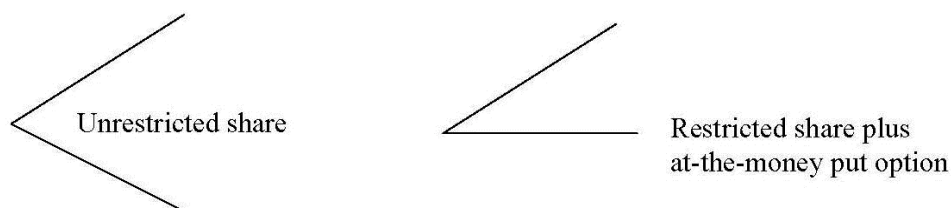

2.144 As shown above, the unrestricted share has both upside and downside risk, both of which are incorporated into the market price of the share. In contrast, the combination of the restricted share and the at-the-money put option limits the downside risk while leaving the potential upside available to the holder. To a marketplace participant, the value of a unit that comprises a restricted share plus an at-the-money put option is inherently greater than the value of an unrestricted share. This occurs because the principal difference between the two (ignoring credit risk of the share option counterparty) is that the combined unit has no downside risk but the unrestricted share does. Therefore, if the value of the restriction is estimated using the put option premium as the amount to be deducted from an unrestricted share (rather than from the fair value of the combined unit), it will overstate the discount attributable to the postvesting restriction.

ASIAN-STYLE PUT OPTIONS

2.145 The Asian protective put method is a variation of the protective put method. It estimates the discount based on an Asian or average rate option rather than a European option that is used in the European protective put model. The method was developed to model some types of restricted stock (e.g., lock-up provisions) for the period after the restriction ends, if the number of shares in the position is much larger than can be liquidated in a single day without affecting the market price of the shares. During the period beyond the end of the restriction, a discount from the market price would not be permitted under ASC Subtopic 820-10, *Fair Value Measurement – Overall*, if a Level 1 valuation were available for the shares. However, for the period that the restriction is in place, the valuation would not be a Level 1 measure when the restriction is security-specific rather than entity-specific. Therefore, an adjustment from the Level 1 price would be needed to reflect the restriction. This adjustment could potentially reflect the time to liquidate the position. When used in that manner, the principal effect of averaging the price over time is a limitation of the volatility (this is also noted in the formula), thereby causing the price of the put to be lower, and thus resulting in a lower implied marketability discount compared to the protective put method. The Asian protective put method is based on a model that provides only limited downside protection. Hence, it is an improvement over the protective put method that provides full protection from downside risks. However, caution should be used with this method as with any put option method, as it may not be a perfect measure of marketability.

FINNERTY PROTECTIVE PUT METHOD

2.145a The Finnerty method also is often used to estimate DLOMs. Like the Asian protective put method, it generally results in lower marketability discounts than the European protective put method. The Finnerty method estimates the DLOM using an arithmetic average strike put option in which the strike price is based on the average value of the underlying asset calculated over a predetermined period. Similar to the Asian protective put method, this method does not completely address the issue of limiting downside risk while leaving upside potential, but it does mitigate the risk. As with any put option based method, and again, similar to the Asian protective put method, caution should be used since it is not a perfect measure of marketability.

HEDGING TRANSACTION WITHOUT UPSIDE

2.146 In share-based payment arrangements, holders of share-based grants with restrictions beyond the vesting period might also be contractually restricted from engaging in transactions to hedge the downside risk during the period of the restriction. However, because this additional restriction (the inability to hedge) is specific to the parties to the transaction (e.g., the grantee in a share-based payment arrangement), it should not be incorporated into the fair value measurement under the guidance of ASC Subtopic 820-10. To estimate the fair value of the restriction (the security-specific aspect of the arrangement), a valuation professional can look at the subset of transactions that does not provide upside potential. The results of the calculation generally can be applied both to those positions for which hedging transactions are permitted and those where they

are not, as the model-based calculations used to value options under ASC Topic 718 are based on the ability to hedge a position (e.g., the Black-Scholes-Merton model involves replicating an option position with a dynamic hedging position in the underlying security), and applied even by those not permitted to hedge because that restriction is entity-specific rather than security-specific.

2.147 Three different sets of transactions can model the cost of locking in a price at the measurement date, without upside or downside risk. If the cash flows are the same, the values also will be the same, so all three alternatives can produce an equivalent estimate of the discount. The alternatives are (1) a forward sale of the shares, (2) a tight collar, and (3) the purchase of an in-the-money put. All involve present value calculations that can be represented by borrowings in actual transactions as described below.

Forward Sale

2.148 This is the most straightforward of the three alternatives. Under this strategy, the holder of the restricted stock would arrange a forward sale of the restricted shares, typically with an equity derivatives dealer, for settlement at a date just after the end of the restriction period. The dealer would price such a transaction based on how it would be hedged.

2.149 To hedge such a transaction, the dealer would borrow the shares from another entity and sell them short. Typically, if the number of shares to be hedged is large, the dealer signs a general agreement that references the average price of the short sales as part of the formula that is used to determine the forward price.

2.150 The dealer will pass along any dividends to the owner of the borrowed shares, plus a stock borrowing fee (if it is an institutional holder) or provide financing at a discount to market rates (if the lender is a brokerage firm). If the shares were borrowed and no financing was provided, acceptable (low risk) collateral to cover the value, plus an extra amount or *haircut* to cover the risk of price changes would have to be posted. For relatively available shares, the borrowing cost, or spread below normal financing rates, which is freely negotiated, often is between 25 and 75 basis points. Certain companies' shares can be harder to borrow, due to lack of float of shares available for lending or substantial existing short interest motivated by convertible arbitrage, merger arbitrage, or speculative selling, and the resulting borrowing cost can be above the higher end of that range. Most stock borrowing arrangements are subject to termination by either party at short notice. Stock borrowing arrangements for longer terms can be arranged, but often at a higher cost, to compensate a dealer for using a portion of its lending capacity or an institutional investor for the lack of flexibility to re-balance its portfolio. The estimated average borrowing cost is not a very transparent input, but inquiries to investment banks with which an entity transacts other business may permit the entity to make a market-based estimate. An alternative approach to estimate the borrow cost using option prices is discussed in Paragraph 2.157.

2.151 The forward sale contract can be modified to include compensation for changes in dividends (and frequently is, because it reduces the risk to the dealer of a forward

purchase). This can be done by either modifying the forward price to reflect how the dividends differed from a specified schedule, or by simply passing them along to the dealer. As the latter makes this calculation simpler, we will assume that dividends are passed along to the dealer, which is equivalent to assuming there will be no dividends on the stock.

2.152 Therefore, the holding cost of being short the shares is the borrow fee, as discussed in Paragraph 2.150, plus the normal compensation the dealer would expect for reducing its lending capacity for the life of the transaction. Because the holder of the restricted shares can pledge the stock (or other collateral) to eliminate the credit risk, it should not be a consequential factor in the dealer's required compensation. This can be observed in the market from spreads for similar (nearly) riskless structured transactions.

2.153 The transaction could be structured as a prepaid forward (a fixed-rate borrowing against the proceeds of the forward sale) or the borrowing could be done elsewhere if a better rate can be obtained. However, this choice does not affect the calculation of the discount. The standard formula for a forward price is:

$$F = Se^{(r-d)T}$$

Where F is the forward price, S is the current stock price, r is the risk-free rate, d is the holding cost, and T is the time in years until delivery. While there is some diversity in practice about which risk-free rate to use (Treasury versus LIBOR), in this case the appropriate risk-free rate is the yield on the collateral pledged to secure the stock borrowing. Because dividends are being passed through to the dealer, the holding cost is merely the sum of the expected borrowing fee plus the cost of *renting a portion of the dealer's balance sheet*. Practically, the holding cost would be expected to be between 0.50% and 2.0%. Because the holder is passing on the dividends, the only cash to be received is the proceeds of the forward sale, the present value of which is calculated and compared to the current price to determine the estimated discount.

2.154 The estimated discount could increase if a different borrowing rate is applied. However, considering that the borrowing can be perfectly collateralized, the use of an entity-specific borrowing rate is not appropriate for this calculation. Thus, the discount becomes:

$$Fe^{-rT} - S = Se^{(r-d)T}e^{-rT} - S = S(e^{-dT} - 1) \approx SdT$$

2.155 Or, in percentage terms, the discount is approximately the holding cost (excluding the dividend) multiplied by the time to the end of the restriction.

Collar

2.156 Partly for tax reasons, holders of stock frequently prefer to buy a put and finance the premium by the sale of a call. Typically these are structured with no net premium at inception. These agreements can also have dividend pass-through clauses similar to those described above, which tend to make the dealer's price more precise, because it eliminates dividend risk for the dealer. The strike price for the put or call depends on the amount of risk or upside the holder wants to retain, and then the dealer would calculate the strike price for the other option (call or put).

2.157 If the strike prices are the same and the structure has a zero premium, then put-call parity means that the volatilities used for the put and the call are the same. Thus, the identical strike prices of such a tight collar would be the same as the forward price, which is why this structure is also called a synthetic forward contract. This alternative is useful if there are options trading on the underlying stock, the prices of synthetic forwards constructed using listed options might help reveal market participants' assumptions about the expected borrowing cost, if the dividend yield was considered to be predictable. Otherwise, there is no advantage to running two option pricing calculations instead of the simpler forward calculation shown above.

In-the-Money Put Option

2.158 There is no particular reason to use an at-the-money strike price for calculating the amount of the discount. If one considers different possibilities and calculates the present value of the minimum amount to be received, a pattern emerges: the higher the strike price, the lower the discount. This happens because the higher the strike price, the less likely there is to be upside payoff, which only is realized if the final stock price is above the strike. The higher the strike price, the higher the initial premium, but the present value of the strike price increases by a greater amount. There is a limit as the minimum net proceeds asymptotically approaches the same result as the other two alternatives discussed above. This illustrates that this approach is a more refined version of the current practice. This alternative should be viewed as a *thought experiment*, useful in illustrating how the other approaches are equivalent to a refined version of the protective put model, not as a transaction that would actually be attempted in practice, because with a strike price that high, typically a forward contract would be used.

Example 2.12: Forward Sale

Assume the following facts:

Stock price is \$100

Restriction term is 2 years

Borrow cost is 0.375% (paid quarterly, actual/360)

Cost of *renting* dealer's balance sheet is 0.625%

Calculate the holding cost input:

Holding cost is 1% compounded quarterly (actual/360), which is equivalent to 1.0126% compounded continuously on a 365-day basis.

Calculate the discount:

$S(e^{-dT}-1)$: $\$100 (e^{-1.0126\% \times 2} - 1) = \2.0048 per share.

Example 2.13: Tight Collar

Assume the same facts as in Example 2.12, but include the following additional facts:

The fixed rates on annual 30/360 swaps are 4.42% for one year and 4.14% for two years. The implied volatility is 30%.

Calculate the risk free rate input:

The two-year discount factor implied by the swap rates is 0.921744, which is equivalent to 4.0510% compounded continuously on a 365-day basis.

Calculate the forward price (which will be the strike prices of the put and the call):

$S e^{(r-d)T} = \$100 e^{(4.0510\% - 1.0126\%) \times 2} = \106.2653 per share.

Calculate the option premiums to see that they are equal:

Put value = \$16.4739 per share

Call value = \$16.4739 per share

Calculate present value of strike price and difference to share price:

$\$106.2653 \times 0.921744 = \$97.9952 \Rightarrow$ Discount of \$2.0048 per share.

Example 2.14: In-the-Money Put Option

Assume the same facts as in Example 2.12, but include the following additional facts:

| Strike price | Premium | PV of Strike | Net | Discount |
|--------------|----------|--------------|---------|----------|
| 100 | 13.2604 | 92.2174 | 78.9570 | 21.0430 |
| 120 | 24.5736 | 110.6609 | 86.0873 | 13.9127 |
| 150 | 46.0721 | 138.3262 | 92.2541 | 7.7459 |
| 200 | 88.1253 | 184.4349 | 96.3096 | 3.6904 |
| 250 | 133.0596 | 230.5436 | 97.4840 | 2.5160 |

| | | | | |
|------|----------|----------|---------|--------|
| 300 | 178.8202 | 276.6523 | 97.8321 | 2.1679 |
| 500 | 363.0949 | 461.0872 | 97.9923 | 2.0077 |
| 1000 | 824.1792 | 922.1744 | 97.9952 | 2.0048 |

Thus, the discount eventually converges to the same level as in the two other methods, although an extremely high strike price is required, due to the tenor and volatility.

The discount when using an at-the-money strike is larger than just the premium, because the time value of money needs to be considered, since the strike is received in the future. This is less significant for stocks that pay higher dividends.

Valuing Private Entity Shares

2.159 A valuation of shares of a private entity will be required when it issues nonvested stock or share options, because share price is an input in an option pricing model. In the absence of observable market prices, the value of such stock is estimated using valuation techniques. It is important to note that the use of a fixed formula, as is often specified in private entity share option or stock agreements, is not consistent with the fair value measurement objective, except when the criteria described in ASC paragraphs 718-10-55-131 through 55-133 are present.

2.160 The AICPA has issued an Accounting and Valuation Guide titled *Valuation of Privately-Held-Company Equity Securities Issued as Compensation*, that addresses valuing private entity equity shares. Although the guide is not authoritative, it is intended to provide measurement guidance that should be considered when valuing equity instruments of privately held entities. We understand that the SEC staff would expect a privately held entity that plans to go public to consider the guidance in the guide. Certain sections in the guide have not been updated for changes to GAAP since the guide was issued, including ASC Subtopic 820-10. Users should be cognizant that changes to some of the guidance may be necessary.

2.161 The guide provides specific guidance on valuations for financial reporting purposes. Key issues to consider when valuing equity securities of privately held entities include:

- **Fair Value Hierarchy.** Consistent with existing U.S. GAAP, the guide indicates that quoted prices in active markets are the best evidence of fair value. While quoted prices are not available for private entities, the entity may have had recent cash transactions for the issuance of shares that can be used to value a security. Use of such transactions would be contingent on (1) the transaction being for the same or similar shares as those being valued, and (2) the transaction being a current transaction between willing parties, i.e., other than on a forced or liquidation basis, and not arising from the terms of a prior transaction (e.g., the strike price of exercised share options would not be regarded as indicative of the fair value of the underlying shares or an

investment by a strategic investor may not be representative of fair value for other shares).

- **Hierarchy of Valuation Alternatives.** The guide states that the reliability of a valuation report depends on the timing of the valuation (contemporaneous or retrospective) and the objectivity of the valuation specialist (unrelated or related). It recommends that an entity engage an unrelated valuation specialist to assist management in determining fair value if neither quoted prices in active markets nor arm's-length cash transactions are available.

The guide establishes a hierarchy for evaluating the reliability of valuations, set out below in declining order of reliability:

- Level A is a contemporaneous valuation by an unrelated valuation specialist.
 - Level B is a retrospective valuation by an unrelated valuation specialist.
 - Level C is either a contemporaneous or retrospective valuation by a related valuation specialist.
- **Rules of Thumb Are Inappropriate.** Rules of thumb should not be applied to value equity shares. For example, rules of thumb that value common shares at a specified discount to a recent round of financing with preferred shares or at a discount to an expected IPO price would be inappropriate.
 - **Bottom-Up versus Top-Down Valuations.** In valuing equity shares of privately held entities, either a bottom-up approach (i.e., the pricing of a recent round of equity financing is used to derive the value of another class of equity) or a top-down approach (i.e., the value of the entity is determined and that value is allocated to its different classes of equity) can be used.

It is very difficult in most situations to estimate the fair value of common shares by using the value of preferred shares and adjusting, on a per-share basis, for the impact of the additional economic and control rights that preferred shares have over common shares. As a result, the guide does not recommend this type of bottom-up approach, which effectively seeks to estimate the discount from preferred shares to common shares on a per share basis without regard to overall enterprise value.

When valuing shares of privately held entities, generally the value of the enterprise as a whole should be established, which is then used to value each class of outstanding shares of the entity. This top-down approach should be based on an evaluation of the different rights of each class of shares, including their liquidation, redemption, or conversion rights. The guide includes extensive discussion on the nature of these rights.

- **Valuation Techniques to Establish Enterprise Value.** Absent quoted prices or comparable cash transactions, other valuation techniques need to be applied to value shares issued by privately held entities. These include the income, market, or asset-based approaches. The selection of method(s) depends, in part, on the nature of the entity and its stage of development.

- In applying an income approach, the guide indicates that either a discount rate adjustment approach or an expected cash flow method may be applied. Interest rates used under the traditional present value approach are usually significantly higher than those of similar public entities calculated using the traditional Capital Asset Pricing Model (CAPM). For example, the required annual rate of return on early stage investments may be 40% to 60%.
- When applying a market approach, consideration should be given to the comparability of the entities used in the market analysis and an understanding that the comparable transactions were on a fair value premise (e.g., not a forced sale) for like shares. Comparable pricing information may not be available for early stage entities.
- A cost or asset approach is generally less conceptually sound for valuing shares of privately held entities. However, an asset approach may be acceptable at an early stage of an entity's development when it is difficult to apply a market or income approach.
- **Valuation Techniques to Allocate Enterprise Value to Different Classes of Equity.** The guide discusses several possible methods of allocating enterprise value to an entity's underlying shares. It refers to these methods as the Current-Value Method, the Option-Pricing Method, and the Probability-Weighted Expected Return Method. It discusses circumstances when each method would be more or less appropriate and provides examples.
 - **The Current-Value Method** allocates value to preferred shares based on its current liquidation or immediate conversion values, whichever is greater. The guide states that a disadvantage of this method is that while it may be easier to understand, it is highly sensitive to the underlying assumptions. It also looks at the current best value for the preferred shares, without regard to possible future price movements. Care should be taken in using this method because it may undervalue the common stock when there is no plan to liquidate or sell the entity in the near future because the common stock frequently derives much of its value from its disproportionate share of the future market value. This occurs frequently for entities emerging from bankruptcy, early-stage entities, and entities financed by private equity investors. At the 2004 AICPA National Conference on Current SEC and PCAOB Developments, the SEC staff stated that they believe the current value method will generally not be appropriate in an IPO filing because such companies are not typically early-stage entities.
 - **The Option-Pricing Method** treats the common and preferred shares as options on the entity's enterprise value. The guide states that a disadvantage of this method is that it may be complex to implement and some of the assumptions, to which it is highly sensitive, for example, the volatility or term, are difficult to objectively estimate. However, this method does capture the option-like characteristics of common stock for

entities whose common stock is a small portion of the total capital structure.

- **The Probability-Weighted Expected Return Method** estimates the value of the common and preferred shares by considering possible scenarios for future enterprise value and realization of return by shareholders (e.g., IPO, sale to a strategic buyer, leveraged recapitalization, and continued operation). The return to the preferred and common shareholders is estimated under each scenario, as are associated probabilities. The guide acknowledges that this approach would be difficult to implement and would require a number of assumptions about possible future outcomes that would be difficult to objectively estimate.
- **Marketability Discounts.** Marketability discounts will often be appropriate when valuing shares of privately held entities. The level of these discounts should be based on an evaluation of the shares' specific facts and circumstances (e.g., prospects for liquidity, restrictions on transferability, size and timing of distributions). The use of rules of thumb or of average or median discounts reported in restricted shares studies is inappropriate.
- **Pre-IPO and IPO Value.** The guide acknowledges that differences would exist between pre- IPO and post IPO values. The guide states that an IPO value would eliminate many of the factors that give rise to a lack-of-marketability discount, by providing liquidity, reducing valuation uncertainties, and reducing ownership concentration.

The guide indicates that significant differences between pre-and post IPO values can exist. A valuation specialist often accounts for the lack of marketability prior to an IPO by applying a marketability discount against the results of the valuation techniques (i.e., under the income, market, or asset-based approaches). Some of the difference in value between private and public entities may also be reflected in the discount rate used in the income approach. The guide indicates that the cost of capital for public entities may be lower, which would cause them to have a higher value than an otherwise comparable privately held entity. The quantification of such differences needs to be carefully considered on a case-by-case basis, based on an entity's specific facts and circumstances.

- **Contents of a Valuation Report.** The guide includes detailed suggestions for the contents of a valuation report. It indicates that a valuation report prepared by a related valuation specialist, including an internal report prepared by management, should contain the same level of information as that prepared by an external valuation specialist.

Summary reports are acceptable if issued as updates to a comprehensive report issued within the last year, when there has been no significant event or major financing that has occurred or is expected to occur.

Q&A 2.14: Valuation Impact of Secondary Market Transactions

Q. How should secondary market transactions be considered in determining the fair value of common stock for a private company when valuing employee share-based payments under Topic 718?

A. A secondary market transaction occurs when common shareholders of private companies sell their holdings to new or existing investors. Secondary transactions could include tender offers as well.

Topic 820 establishes the framework for determining fair value and requires valuation techniques to maximize the use of relevant observable inputs. Topic 718 does not have a similar requirement to maximize the use of observable inputs, even though the measurement objective remains largely the same as in Topic 820. That is, the objective is to determine a value that reflects the price that would be paid in a current transaction between willing parties other than in a forced or liquidation sale. When employees or nonemployees sell shares in a secondary offering, management should evaluate whether the transaction price the purchasers paid reflects fair value as defined in the relevant Topic.

Chapter 8 of the AICPA guide “Valuation of Privately Held Company Equity Securities Issued as Compensation” provides guidance on the valuation of common stock for privately held companies, which requires entities to consider the relevance of secondary market transactions when determining the fair value of common stock. Determining the relevance of secondary market transactions for estimating the fair value of common stock requires significant judgment and an analysis of the specific facts and circumstances.

Factors to consider include:

- **Number of secondary market transactions** – the larger the number of secondary market transactions and the greater number of transacting parties, the stronger the indicator that the transaction price represents fair value under Topic 820. A pattern of transactions should be considered, including the potential to repeat transactions or a clear indication that the transactions are one-time transactions.
- **Volume of secondary market transactions** – the higher the percentage of stock that has been sold through secondary market transactions, the stronger the indicator that there is an active market and the transaction price represents fair value. However, the fact that a small percentage of the total stock pool has been transacted does not suggest on its own that the transaction is not at fair value.
- **Timing of the secondary market transactions** – the proximity of the transaction date to the valuation date indicates the relevance of the transaction to the estimated fair value of the common stock. Secondary market transactions that occur closer to the valuation date provide stronger evidence that the transaction price reflects fair value at the valuation date. However, the fact that time has passed since a significant secondary transaction does not

mean a company can disregard the transaction without considering if it remains a relevant data point for valuation purposes. For example, prior transactions may provide useful information about how investors are assessing future prospects (e.g., likelihood of an exit event that eliminates liquidation preferences for senior classes of stock) that can be rolled forward for new information since the date of the observed transaction to the valuation date. Information provided by relevant observable transactions should be considered in choosing and calibrating other valuation approaches.

- **Consistency of pricing** – consistency in pricing for secondary market transactions is a strong indicator that the price paid reflects fair value. For example, multiple, unrelated secondary market transactions occurring in close proximity at a similar price or in a similar pricing relationship to other classes of stock (e.g., preferred stock).
- **Counterparty to the transaction** – whether or not the counterparty has an economic interest in the company or is a new investor may impact the determination of whether the transaction is orderly. For example, certain economic interest holders may have a strategic reason for the investment (e.g., gaining a Board seat) that should be considered when assessing the impact of the transaction on the estimated fair value of the common stock. However, the fact that a transaction is with a related party does not mean a company can ignore the transaction. Rather, the economics of the transaction should be understood and factored into the overall assessment of fair value to the extent relevant information is present.
- **Information available to the investor** - whether the investor has sufficient information to make an informed investment decision including whether the information available to the investor is consistent with the information that would be available to a market participant and to the seller. The level of sophistication of the investor also may provide evidence as to the relevance of the transaction for fair value purposes. For instance, sophisticated investors would normally be presumed to be purchasing securities based on adequate information.
- **Proximity of exit event** – as the prospects for an exit (e.g., IPO) increases, we have observed that investors place less importance on liquidation preferences associated with preferred stock. In some cases, the value of the common stock starts to converge with the value of the preferred stock, due to the fact that preferred stock often converts to common in an IPO or another liquidation event if the company is sold. Transactions where the transaction price is near or equal to the preferred stock issue price may indicate the market participant believes a liquidity event will occur and may be a strong indicator that there is not much difference in value between preferred stock and common stock prices. Such information should not be ignored because a company has not commenced an IPO or other exit process.
- **Is it an orderly transaction?** – Topic 820 defines an orderly transaction as “a transaction that assumes exposure to the market for a period before the

measurement date to allow for marketing activities that are usual and customary for transactions involving such assets or liabilities; it is not a forced transaction.” In private company transactions, the usual and customary marketing activities generally include time for the investors to perform due diligence and to discuss the company’s plans with management or the board of directors, or both.*

It should be stressed that than none of the indicators above should be viewed in isolation and that this should not be viewed as a checklist or simple mechanical weighting exercise. While there may be a high level of judgment in these circumstances, consistent with the objectives of Topics 820 and 718, the estimate of fair value should reflect a neutral evaluation of how a willing buyer and willing seller would transact on the date in question, considering all available evidence, including evidence from secondary transaction pricing and all other available relevant information. For example, when general market conditions indicate that market participants in secondary transactions of other similarly situated companies are showing valuations consistent with high expectations of a successful exit transaction, the absence of specific secondary transactions in the subject company is **not** a basis to revert to legacy models that assign a low probability to an exit event. That is, evidence from transactions in the stock of similarly situated companies may be observable and should be considered in work performed to calibrate and validate that the underlying valuation model is reasonable in relation to overall market conditions.

Based on the assessment of the relevance of the secondary market transactions, entities must determine the appropriate valuation technique that maximizes the use of relevant observable inputs. We believe entities can broadly categorize the significance of such transactions into three categories:

| Category | Example characteristics | Evaluation |
|--|--|---|
| <p>Category 1</p> <p>Limited weighting provided to observed transactions</p> | <ul style="list-style-type: none"> • Limited secondary market transactions • Early-stage entity with limited information provided to investors • De minimis volume of shares transacted | <ul style="list-style-type: none"> • In these circumstances, other valuation approaches (i.e., approaches other than observed transactions in stock) often provide the primary evidence of value • Depending on the size and nature of the secondary market transactions, observed transaction activity may not provide relevant and reliable information in choosing or calibrating valuation approaches and assumptions unless general market conditions for other similarly situated companies provide strong evidence to the contrary |

| | | |
|---|---|---|
| | | <ul style="list-style-type: none"> Some weight may be given to the observed transaction pricing, depending on the facts, and other valuation approaches should consider general market conditions applicable to the company (e.g., does the company occupy a market in which stock is generally traded based on an assumption that an IPO or equivalent exit will ultimately occur?). |
| <p>Category 2</p> <p>Significant judgment to determine approach</p> | <ul style="list-style-type: none"> Multiple secondary market transactions Moderate volume of shares transacted Unclear if price is repeatable because of particular facts and circumstances in each transaction | <ul style="list-style-type: none"> In these circumstances, significant judgment is required to determine the appropriate valuation approaches and assumptions to use, the best way to calibrate it, and the weighting put on different pieces of evidential matter While there may be a high level of judgment in these circumstances, consistent with the objective of Topics 820 and 718, fair value should reflect the best estimate of how a willing buyer and willing seller would transact on the date in question, considering all available evidence. A simple weighting of observed price versus a model value is generally not appropriate—rather, all available data should be considered and the best estimate of exit price for the security determined. |
| <p>Category 3</p> <p>Observed transaction prices or model calibrated to observed transaction prices provides primary evidence</p> | <ul style="list-style-type: none"> High volume of secondary market transactions and high volume of shares transacted Evidence of orderly and relevant transactions with informed investors at consistent pricing Transactions occurring at or near the preferred stock | <ul style="list-style-type: none"> In these circumstances, observed transaction pricing should be weighted heavily. To the extent observed pricing differs significantly from the value derived using valuation approaches excluding the secondary market transactions, the type of valuation approach and assumptions used should be reassessed and/or reconciled. For example, if observed transaction prices for common stock are consistently at or near the preferred |

| | | |
|--|--|---|
| | <p>price as investors anticipate a liquidity event</p> | <p>stock price and an option pricing model is suggesting a much lower price for the common stock, this can indicate a potential issue with the assumptions used in the option pricing model. In this situation, inputs into the option pricing model like assumed volatility and assumed time to exit should be carefully reevaluated from a market participant perspective. Furthermore, it may be appropriate to consider alternative valuation models like a PWERM that explicitly factors in implied investor expectations under different scenarios.</p> <ul style="list-style-type: none"> • The conclusion of value from the valuation approaches and the observed pricing of secondary market transactions should generally be explicitly reconciled in these cases. |
|--|--|---|

If observed transactions in common stock are not considered to represent fair value or are given only limited weight in estimating the fair value, it is a best practice for the company and valuation specialist to compare the estimated fair value of the securities to the transaction prices, explaining the differences to the extent the available information allows and the rationale for the selected weighting (AICPA *Valuation of Privately-Held Company Equity Securities Issued as Compensation*, Section 8.14). Also see Paragraph 1.026a, Q&A 1.21a, 5.20a, and Q&A 5.7b.

*AICPA *Valuation of Privately-Held Company Equity Securities Issued as Compensation*, Section 8.08

PRACTICAL EXPEDIENT FOR VALUING PRIVATE ENTITY SHARES

2.161a Nonpublic entities may apply a practical expedient that allows flexibility in determining the share price for equity-classified awards (e.g., nonvested shares or the option-based award share price input to an option pricing model) by using a ‘reasonable application of a reasonable valuation method’. A valuation method is considered reasonable if it considers all available information material to the value of the private entity. The determination of whether a valuation method is reasonable, or whether an application of a valuation method is reasonable, is made based on the facts and circumstances as of the measurement date. Factors to be considered under a reasonable valuation method include, as applicable:

- The value of tangible and intangible assets of the nonpublic entity.
- The present value of anticipated future cash flows of the nonpublic entity.

- The market value of stock or equity interests in similar corporations and other entities engaged in trades or businesses substantially similar to those engaged in by the nonpublic entity for which the stock is to be valued, the value of which can be readily determined through nondiscretionary, objective means (such as through trading prices on an established securities market or an amount paid in an arm's-length private transaction).
- Recent arm's-length transactions involving the sale or transfer of stock or equity interests of the nonpublic entity.
- Other relevant factors such as control premiums or discounts for lack of marketability and whether the valuation method is used for other purposes that have a material economic effect on the nonpublic entity, its stockholders, or its creditors.
- The nonpublic entity's consistent use of a valuation method to determine the value of its stock or assets for other purposes, including for purposes unrelated to compensation of service providers.

2.161b A valuation performed under IRC Section 409A is an example of an application and methodology that would be acceptable under the practical expedient because the measurement objective (fair market value) of ASC Topic 718 and the Treasury Regulations related to IRC Section 409A are similar. Generally, a value calculated under the Treasury Regulations is considered valid for 12 months after the valuation date unless the value would be considered grossly unreasonable. However, a value is not reasonable as of a later date, and therefore a new valuation is needed, if it does not reflect information available after the valuation date that materially affects the company's value. As a result, while using a Section 409A valuation is an example of how to apply the practical expedient, that valuation cannot be relied on without considering whether subsequent events materially affect the share's value.

2.161c The practical expedient is available for both employee and nonemployee awards, must be elected on a measurement date-by-measurement date basis, and is applied to all equity-classified share-based payment awards with the same underlying share and measurement date. ASC paragraphs 718-10-30-20C – 30-20H

OTHER MEASUREMENT ISSUES

Valuing Employee Share Purchase Plans with Look-Back Share Options

2.162 An entity may provide its employees with the opportunity to purchase its shares often at a discount from the market price through a formal arrangement called an employee share purchase plan (ESPP). A discount in an ESPP is not compensatory if:

- The plan satisfies at least one of the following conditions:
 - The terms of the plan are no more favorable than those available to all holders of the same class of shares.

- Any purchase discount from the market price does not exceed the per-share amount of share issuance costs that would have been incurred to raise a significant amount of capital by a public offering. A purchase discount of 5% or less from the market price should be considered to comply with this condition without further justification. A purchase discount greater than 5% that cannot be justified under this condition results in compensation cost for the entire amount of the discount.
- Substantially all employees that meet limited employment qualifications may participate on an equitable basis.
- The plan incorporates no option features, with limited exception as discussed below.

2.163 Some entities include look-back options in their ESPP arrangements. While a look-back option can take many forms, in general the option permits employees to apply the discount to the price of the shares at either the beginning or end of the *look-back* period.

2.164 For ESPP arrangements that contain look-back options, the fair value of the award is the value of the discount plus the fair value of the look-back option. As with other option features included in grants to employees, the fair value of a look-back option is determined at the grant date.

2.165 A look-back option will cause an ESPP to be compensatory. The only option-like features the plan may have without being compensatory are:

- Employees are permitted a short period of time – not exceeding 31 days – after the purchase price has been fixed to enroll in the plan.
- The purchase price is based solely on the market price of the shares at the date of purchase, and employees are permitted to cancel participation before the purchase date and obtain a refund of amounts previously paid (such as those paid by payroll withholdings). ASC paragraph 718-50-25-1

Most ESPPs will be compensatory because their look-back provisions do not meet these criteria.

2.166 ASC paragraphs 718-50-55-10 through 55-21 provide guidance on the valuation of one type of look-back option, i.e., when the holder is entitled to buy a known number of shares of a company's stock at a fixed discount based on the lesser of the stock price on the date of grant and the stock price on the date of exercise. Guidance on valuing other look-back arrangements is provided in ASC Section 718-50-55, which also is relevant for ESPP arrangements under ASC Topic 718.

Example 2.15: Valuing a Look-Back Share Option

ABC Corp. grants a one-year share option to employees to buy shares at 85% of either the grant-date share price or the share price at the end of the year. Thus, the employees

have the ability to buy the shares at a 15% minimum discount from the market price. Assume the expected volatility is 50%, the current share price is \$100, the expected risk-free rate is 6%, and the expected dividends are 2%. Payment for the ESPP is made through payroll withholding over the enrollment period.

Because the exercise price is subject to the 85% adjustment of the lower of the grant-date share price or the end-of-year share price, the share option is always in the money by at least 15%. This means that the minimum payoff is 15% of the share price and this element of the share option is equivalent to 15% of a nonvested share. However, because the share option is only exercised at expiration, the holder does not benefit from dividends. Instead, the shares into which the share options are exercisable will decline in value with the payment of dividends. Therefore, the present value of the estimated dividends should be deducted from the current share price. In this example, the dividend-adjusted current share price is determined as follows:

| | | |
|--|----|---------------------|
| Share price | \$ | 100.00 |
| Dividend $100 \times e^{-2\% \times 1 \text{ Year}}$ | | <u>1.98</u> |
| Adjusted share price | \$ | <u>98.02</u> |
| The value of the implicit nonvested share | \$ | <u><u>14.70</u></u> |

The value of the implicit nonvested share of \$14.70 is 15% of the adjusted share price. In addition to this value, the holder also has 85% of a share option with an exercise price of \$100. Using an option pricing model, the 100% value of such a share option is \$13.48, and 85% of that value is \$11.45. The total value of the share option is therefore \$26.15, which is:

| | | |
|------------------------------------|----|---------------------|
| The implicit nonvested share value | \$ | 14.70 |
| 85% of the 1-year share option | \$ | <u>11.45</u> |
| | \$ | <u><u>26.15</u></u> |

2.167 ASC Section 718-50-55 provides guidance on methodologies that may be employed to value more complex look-back arrangements. The examples given in ASC Section 718-50-55 are classified as Type A through Type I arrangements. These plans are all compensatory but differ as follows:

- Whether the maximum number of shares that a participant may purchase is set at the outset of the arrangement (Type A, as discussed in Example 2.15) or, assuming a fixed amount is contributed, whether the participant can purchase more shares if the share price falls (Type B).
- Whether there are multiple purchase periods, with or without reset or rollover mechanisms or semi-fixed withholdings (Types C, D, E, and F). Reset refers to when the maximum purchase price is reduced from the original grant date purchase price to a lower price at an interim purchase date for subsequent purchases. Rollover refers to a plan in which, when the price at an interim purchase date is below the original grant date price, a new plan is started with a term equal to the existing plan's original term. Semi-fixed withholding

refers to when an employee at each interim purchase date can elect to vary the amount to be withheld for subsequent periods.

- Whether there is a single or multiple purchase period(s) with variable withholdings (Types G and H). With variable withholding, an employee can elect to change future withholding at any time during the term of the plan.
- Whether there is a single purchase period with variable cash withholdings and cash infusions (Type I). Under this plan, an employee can elect at any point to purchase more stock. This is equivalent to an ability to retroactively adjust withholding.

2.168 Example 2.15 describes the value of Type A plans. As that example shows, such an arrangement may be valued as a fractional share and call option. Under this type of arrangement, the maximum number of shares subject to the share option is fixed at the start of the period (equal to the fixed withholding divided by the opening share price). Therefore, if the stock price falls, the participant's aggregate purchase price falls in line with the decline in the stock price. As a result, the aggregate profit is reduced proportionately (notwithstanding that the minimum percentage profit per share is maintained by the look-back feature). For example, if an employee agrees to have \$1,000 withheld to purchase shares in an ESPP and the price at the grant date is \$20, the maximum number of shares that can be purchased is 59 (i.e., $\$1,000/(\$20 \times 85\%)$). This would have yielded a profit on the grant date of \$177, i.e., $\$1,000/85\% \times 15\%$ or 59 shares $\times (\$20 - \$17)$. If the stock price falls 25% to \$15, the profit realized will also fall 25% to \$133 (59 shares $\times (\$15 - \$12.75)$ (allowing for rounding).

2.169 Under a Type B plan, the number of shares that a participant can acquire is variable (up to that available using the fixed amount withheld, which is set at the outset). This means that if the stock price declines, the employee is able to purchase more shares. Thus, the profit realized is always at a minimum equal to 15% of the market price of the shares purchased with the withheld amount (note that a 15% return on the market price is a higher return on the amount withheld (1 – discount %)). For example, if an employee agrees to have \$1,000 withheld to purchase shares in an ESPP and the price at the grant date is \$20, the profit on the grant date is \$177, i.e., $\$1,000/85\% \times 15\%$ or 59 shares $\times (\$20 - \$17)$. If the stock price falls 25% to \$15, the profit realized will remain at \$177 (78 shares $\times (\$15 - \$12.75)$ (allowing for rounding).

2.170 Thus, a Type B arrangement protects an employee's minimum aggregate profit from adverse movements in the stock price (whereas a Type A arrangement provides a minimum fixed percentage return per share). A Type B arrangement can be valued similarly to the Type A arrangement but with the addition of a fractional put option on a share of stock.

Example 2.16: Valuing a Type B Look-Back Share Option

The payoffs on a Type A and Type B look-back share option are compared below, demonstrating that the payoff on a Type B share option is equivalent to the payoff on a fractional share, put option, and a call option.

| | | | | |
|---------------|---------|-------|-------|---------|
| Opening price | | | | \$50.00 |
| Discount | | | | 15% |
| Closing price | \$10.00 | 30.00 | 50.00 | 60.00 |
| Exercise | \$8.50 | 25.50 | 42.50 | 42.50 |
| Profit | \$1.50 | 4.50 | 7.50 | 17.50 |

Type A: Fixed Number of Shares

| | | | | |
|-----------------------------|------------|--------|--------|----------|
| Investment | \$4,250.00 | | | |
| Price | \$42.50 | | | |
| Fixed number of shares | 100 | 100 | 100 | 100 |
| Aggregate profit | \$150.00 | 450.00 | 750.00 | 1,750.00 |
| Decline in stock price | 80% | 40% | n/a | n/a |
| Decline in aggregate profit | 80% | 40% | n/a | n/a |

For a Type A plan, aggregate profit declines at the same percentage as any decline in the stock price. The percentage profit per share is unchanged.

Type B: Fixed Number of Shares

| | | | | |
|-----------------------------|------------|--------|--------|----------|
| Investment | \$4,250.00 | | | |
| Price | \$8.50 | 25.50 | 42.50 | 42.50 |
| Number of shares | 500 | 166.7 | 100 | 100 |
| Value | \$750.00 | 750.00 | 750.00 | 1,750.00 |
| Decline in stock price | 80% | 40% | n/a | n/a |
| Decline in aggregate profit | n/a | n/a | n/a | n/a |

The number of shares the employee can buy offsets the decline in the stock price, preserving the minimum profit. Neither Type A nor Type B allows the employee a different percentage profit per share, if the stock price declines.

Comparison of Type A and Type B

| | | | | |
|------------------------------------|----------|--------|---|---|
| Difference in aggregate fair value | \$600.00 | 300.00 | — | — |
|------------------------------------|----------|--------|---|---|

Type B plans provide downside protection against stock price declines. The aggregate payoff is the same for stock price increases.

Valuation

This can be modeled as a fractional stock put and call:

| | | | | |
|---------------------------|----------|--------|--------|----------|
| Stock | | | | |
| Value | \$10.00 | 30.00 | 50.00 | 60.00 |
| Percent | 15% | 15% | 15% | 15% |
| Fractional value | \$1.50 | 4.50 | 7.50 | 9.00 |
| Put | | | | |
| Value | \$40.00 | 20.00 | — | — |
| Percent | 15% | 15% | 15% | 15% |
| Fractional value | \$6.00 | 3.00 | — | — |
| Call at grant date | | | | |
| Value | — | — | — | 10.00 |
| Percent | 85% | 85% | 85% | 85% |
| Fractional value | — | — | — | 8.50 |
| Total value | \$7.50 | 7.50 | 7.50 | 17.50 |
| Number of shares | 100 | 100 | 100 | 100 |
| Aggregate value | \$750.00 | 750.00 | 750.00 | 1,750.00 |

2.171 Type A or Type B arrangements can also be valued using the following formulas:

Type A

The payoff at the end of the term of a Type A ESPP is based on a 15% discount to the lower of the opening stock price (S_0) or closing stock price (S_t). Therefore, the payoff at the end of the term is:

$$\text{Payoff} = S_t - 85\% * \text{Min}(S_t, S_0)$$

This actual payoff depends on whether the closing stock price, S_t , is greater than or less than the opening stock price, S_0 . If the stock price falls during the period, the exercise price for the ESPP will be based on the closing stock price and the payoff will be a 15% discount off the closing stock price.

$$\text{For } S_t < S_0 = S_t - 0.85 * S_t = 0.15 * S_t$$

When the stock price increases during the period, the exercise price for the ESPP will be based on a 15% discount off the opening price.

$$\text{For } S_t > S_0 = S_t - 0.85 * S_0$$

By combining these formulas, at any future stock price (i.e., whether S_t is greater than, equal to, or less than S_0), the payoff on the ESPP is at least 15% of S_t . Further, all future stock prices (S_t), once probability-weighted and discounted to the present, must equal the current stock price. Therefore,

$$\begin{aligned} S_0 &= 0.15 * S_t + 0.85 S_t - 0.85 * S_0 \text{ (where } S_t \text{ is bifurcated into } .15 S_t \text{ and } .85 S_t) \\ &= 0.15 * S_t + 0.85(S_t - S_0) \end{aligned}$$

In addition, if the stock price increases during the term, the ESPP has additional value, similar to the value of a share option. The payoff on a call option is equal to $S_t - S_0$ where $S_t > S_0$, so that the right hand term is the formula for a share option multiplied by 85%.

Therefore, the ESPP value is equal to 15% of the current stock price, i.e., 15% of S_0 , plus 85% of a share option using the current price as the exercise price.

Type B

In a Type A ESPP, the percentage return that a participant will receive is set at a minimum of 15%. However, if the stock price declines and the employee is entitled to receive a fixed number of shares, the employee will receive a lower dollar amount at payoff than he or she would have if the price had been unchanged during the period, i.e., lower price times a fixed number of shares. In a Type B ESPP, the number of shares issued to the employees adjusts to ensure that the employee receives at least the opening stock price times the discount. This is equivalent to a downside protection feature. Therefore, while the effect of a Type B plan is achieved by issuing additional shares, it can be valued based on the current number of shares plus a put option.

For $S_t > S_0$

$$\begin{aligned} \text{Payoff} &= S_t - 0.85 * S_0 \\ &= 0.15 * S_t + 0.85 S_t - 0.85 * S_0 \text{ (where } S_t \text{ is bifurcated into } .15 S_t \text{ and } .85 S_t) \\ &= 0.15 * S_t + 0.85(S_t - S_0) \\ &= 15\% \text{ of the stock and } 85\% \text{ of a call option} \end{aligned}$$

For $S_t < S_0$

$$\begin{aligned} \text{Payoff} &= 0.15 S_0 \\ &= 0.15 S_0 - 0.15 S_t + 0.15 S_t \\ &= 0.15 S_t + 0.15 (S_0 - S_t) \\ &= 15\% \text{ of the stock plus } 15\% \text{ of a put option.} \end{aligned}$$

2.172 In a Type C plan, which has multiple purchase periods, a fixed amount is withheld over a certain period. During this period, there are multiple purchase dates. The purchase price for each purchase period is equal to $(1 - \text{discount } \%)$ times the lesser of the price on the grant date and the price on each purchase date. The different purchase dates are analogous to a graded vesting arrangement. Each tranche would be separately valued using the fractional share and call option approach used to value a Type A arrangement. The value of the fractional option for each tranche would differ, reflecting the different lives of each tranche, measured from the initial grant date to each separate purchase date.

2.173 Type D to Type H plans are treated similar to a Type C plan. However, if a reset or rollover mechanism becomes effective, it is treated as a modification to the plan and is subject to the modification provisions discussed in Section 5, *Modification of Awards*. Similarly, valuations of plans with variable withholding (i.e., Type F to Type H plans) should be based on estimated withholdings with changes treated as modifications. ASC Section 718-50-55 includes an illustration of calculating fair value for such modifications.

2.174 Type I plans allow variable cash withholdings and cash infusions. ASC Section 718-50-55 indicates that such arrangements imply that the employer and employee do not have a mutual understanding of the terms and conditions so measurement is delayed until such an understanding is obtained (generally at the end of the period when the employee determines the amount to contribute).

TRANSITION FROM NONPUBLIC TO PUBLIC ENTITY STATUS

2.175 SAB Topic 14.B provides transition guidance for entities that cease to meet the definition of nonpublic (e.g., on first filing a registration statement with the SEC) and can no longer apply the practical expedients and policy elections available to nonpublic entities to value their share-based payment awards. The table below is based on SAB Topic 14.B.

| Practical expedient | Expedient description | Transition to public entity |
|---------------------------------------|--|---|
| Calculated value | Using an industry index instead of an entity's historical volatility to determine the value of an award. (See Paragraph 2.048) | Continue to use calculated value for all instruments granted prior to becoming a public entity unless the instruments (i.e., share options) were subsequently modified, repurchased or cancelled after becoming a public entity. If so, reassess using public entity guidance (i.e., use fair value to determine any incremental compensation). |
| Measuring liability-classified awards | Using intrinsic value instead of fair value to measure liability-classified awards (See Paragraph 3.001) | Use fair value determined under ASC Topic 718 to measure liability-classified awards in the first reporting period after becoming a public entity. In that first reporting period there will be an incremental amount of measured cost for the difference between fair value and intrinsic value. |

An entity may not retrospectively measure at fair value awards that were granted before the date it became a public entity.

The SEC staff expects the entity to disclose the effects of the changes in accounting policy, and clearly describe the changes in its MD&A.

SAB Topic 14.B does not discuss transition guidance for the other practical expedients available to nonpublic entities. We believe a nonpublic entity should follow the guidance below when transitioning to a public entity.

| Practical expedient | Expedient description | Transition to public entity |
|--|--|--|
| Expected term | Using a simplified method for awards with service conditions or performance conditions that are probable of achievement. (See Paragraph 2.030a) | May continue to recognize compensation cost using the practical expedient for all equity-classified instruments granted prior to becoming a public entity unless the instruments (i.e., share options) were subsequently modified, repurchased or cancelled after becoming a public entity. If so, reassess using public entity guidance (which may include using the simplified method in SAB Topic 14.D for ‘plain vanilla’ options). See discussion beginning at Paragraph 2.062. |
| | We believe that an entity may apply by analogy the SAB Topic 14.D transition guidance for the volatility practical expedient to the expected term practical expedient. This is because a) the expected term practical expedient is similar in concept to the simplified method allowed by SAB Topic 14.D (which is limited to ‘plain vanilla instruments’) and b) both volatility and expected term are inputs into an option-pricing model, and SAB Topic 14.D already prescribes transition guidance for one of the inputs (volatility). | |
| Current price input for equity classified awards | Using a ‘reasonable application of a reasonable valuation method’ to determine share price (See Paragraph 2.161a) | We believe that an entity should apply the public company guidance in all periods. However, if the valuation using the expedient represents grant date fair value, or any adjustments needed to determine fair value are not significant, the entity may not need to make a change. |

¹ Entities that are unable to reasonably estimate the fair value of a share option or similar instrument should measure the instrument at intrinsic value at each reporting date through the date of settlement. An inability to measure the fair value of an equity instrument is expected to be extremely rare and is likely to be an indication that there has not been a grant because there may not be a mutual understanding of the terms. ASC paragraphs 718-10-30-21 and 30-22

² Nonpublic entities are permitted to make a policy election to measure all their liability-classified share-based payment arrangements at fair value or intrinsic value. Whether fair value or intrinsic value is selected, the liability must be remeasured at each reporting date through the date it is settled.

³ By ignoring vesting when valuing a share, share option, or similar instrument, the value of the instrument is essentially separated from the issue of how it is paid for. With a share option, the provision of the goods delivered and services rendered generally is how the grantee pays for the award. Therefore, grantee share options are not exercisable until they vest because they have not been *paid for* until the goods have been delivered or the services have been rendered. However, exchange-traded options are generally exercisable immediately because the premium or cost of the share option is paid up front.

⁴ The staff of the SEC's Office of Economic Analysis (OEA) evaluated the possible use of market-based measures to value employee awards. They indicated that the prices paid by investors for market instruments with the same terms and conditions as employee awards would "not yield a transaction price that is a reasonable measure of the cost of the option grant to the issuer and, thus, will not meet the fair value measurement objective of the standard." The OEA's staff indicated that the cost to the entity should be based on employees' rather than investors' exercise decisions. The OEA's staff indicated that fair value measures might be derived from instruments that tracked the payoff to employees. However, other conditions, such as adequate marketing and release of sufficient information to allow the market to price the instrument would be necessary. Furthermore, if otherwise appropriate market-based measures were significantly different from model derived values, an entity would need to reconcile the results. *Economic Evaluation of Alternative Market Instrument Designs: Toward a Market-Based Approach to Estimating the Fair Value of Employee Stock Options*, August 31, 2005.

⁵ ASC Topic 718 acknowledges that a marketplace participant, when estimating the fair value of an instrument, would consider the probability of its vesting. However, in applying the provisions of ASC Topic 718, the effect of vesting conditions is reflected by only recording compensation cost for share options for which the goods are delivered or services are rendered. ASC paragraph 718-10-55-12

⁶ See footnotes 1 and 2 of this section for circumstances in which entities may apply intrinsic value. However, even when that alternative is available, intrinsic value is not a measure of fair value.

⁷ As discussed in Paragraph 2.036, the ability to exclude or weight less heavily the volatility of a particular historic period will depend, in part, on whether the volatility of that specific period is attributable to a company-specific factor or to broader market-related events. In general, it is difficult to assert that a market-related event is not expected to recur. As a result, adjusting the volatility by placing a lower weight on the volatility for a particular period on factors primarily attributable to a market-related event generally is not appropriate.

⁸ In a speech at the 2005 AICPA National Conference on Current SEC and PCAOB Developments, Alison T. Spivey, associate chief accountant at the SEC, indicated that a method of estimating historical volatility that uses the average value of the daily high and low share prices to compute volatility also would be inappropriate. The text of her speech (12/05/05) is available at <http://www.sec.gov/news/speech/spch120505as.htm>.

⁹ LEAPs are traded options with no longer terms than ordinary exchange-traded options.

¹⁰ An existing entity's shares will have a different volatility over a one-year period than over a two- or three-year period. This difference in volatility for different terms is referred to as the term structure of volatility.

¹¹ Just as interest rates change, the term structure may change so that the relationship between short-term and long-term maturities changes over time.

¹² Many entities have provisions in their employee share option awards that require an employee who is leaving to exercise his or her vested share options within a short period of time, such as 30 to 90 days.

¹³ Expected term is a required disclosure under ASC Topic 718. A lattice model may be programmed to calculate the expected term of a share option. However, ASC paragraph 718-10-55-30 states that an acceptable method to estimate expected term based on the results of a lattice model is to use the lattice model's fair value estimate as an input into a closed form model and solve the model for expected term.

¹⁴ An entity may also consider the effect of clauses that accelerate vesting of an award on death or disability in estimating the expected term of an employee award.

¹⁵ The lattice model may be implemented using exactly the same assumptions as the Black-Scholes-Merton model, in which case the results under either approach would be the same or very similar, assuming a sufficient number of intervals are chosen for the lattice model. However, the lattice model can be adapted to incorporate additional input assumptions, including potential drivers of early exercise behavior, as well as different volatilities, risk-free rates, and dividend yield at different nodes.

¹⁶ In a speech at the 2004 AICPA National Conference, Todd Hardiman, associate chief accountant at the SEC, discussed share-based compensation measurement issues. The text of his speech (12/6/04) is available at <http://www.sec.gov/news/speech/spch120604teh.htm>.

Section 3 - Classification of Awards as Either Liabilities or Equity

Detailed Contents

Effect of Award Conditions on Classification *Other* Condition

Q&A 3.1: Award with Other Condition

Q&A 3.2: Award with Other Condition--Gross National Product

Q&A 3.3: Award with Comparison to Peer Companies

Q&A 3.4: Award with Comparison to Peer Companies--Same Performance Measure

Q&A 3.5: Award Indexed to Trading Volume of a Company's Stock

Q&A 3.5a: Award with Scope 3 Emissions Target

Awards Permitting Settlement in Shares

Example 3.1: Awards Settled in Shares

Awards Requiring or Permitting Settlement in Cash

Guarantees of the Value of Stock Underlying an Option Grant

Example 3.2: Guarantees of the Value of Stock

Awards Settled Partially in Cash and Partially in Shares

Exceptions to Liability Classification for *Cash-Settled* Awards

Puttable Arrangements

Exposure to Economic Risks and Rewards

Reasonable Period of Time

Example 3.3: Put Features

Q&A 3.6: Effect of Put Features on Award Classification

Q&A 3.7: Effect of Put Features on Award Classification--*Reasonable Period of Time*

Q&A 3.8: Share Option with a Put Feature

Q&A 3.9: Effect of Fixed-Price Put Features on Award Classification

Q&A 3.9a: Effect on Award Classification of a Noncompensatory Employee Share Purchase Plan Based on a Formula with a Repurchase Feature

Impact of Timing of Appraisals

Impact of Timing of Appraisals on Classification

Q&A 3.10: Effect of Timing of Appraisals on Classification of Awards – Part I

Q&A 3.11: Effect of Timing of Appraisals on Classification of Awards – Part II

Impact of Timing of Appraisals on Grant Date

Q&A 3.12: Effect of Timing of Appraisals on Grant Date – Part I

Q&A 3.13: Effect of Timing of Appraisals on Grant Date – Part II

Broker-Assisted Cashless Exercise

Other Cashless Exercises

- Q&A 3.14: Use of Immature Shares in Stock-for-Stock Exercise
- Q&A 3.15: Immaculate Cashless Exercise
 - Additional Requirements for Related Brokers
- Q&A 3.16: Use of a Broker to Effect a Cashless Exercise
- Q&A 3.17: Use of a Related Broker
 - Tax Withholding
- Q&A 3.18: Statutory Tax Withholding – Part I
- Q&A 3.19: Statutory Tax Withholding – Part II
- Q&A 3.20: Statutory Tax Withholding – Part III
- Q&A 3.20a: Statutory Tax Withholding – Changes in Withholdings
- Q&A 3.20aa: Employee Cash Bonus Linked to Vesting of Nonvested Shares – Part I
- Q&A 3.20b: Employee Cash Bonus Linked to Vesting of Nonvested Shares – Part II
- Q&A 3.20c: Employee Cash Bonus Linked to Vesting of Nonvested Shares – Part III
- Q&A 3.21: Employee Cash Bonus Linked to Vesting of Nonvested Shares
- Q&A 3.22: Employee Cash Bonus Linked to Exercise of a Share Option
- Q&A 3.23: Payments Made Pursuant to Expatriates’ Tax Equalization Program
- Q&A 3.25: Payment of Brokerage Commissions on Exercise of a Share Option
 - Callable Arrangements
- Example 3.4: Examples of Events That Affect Repurchase Feature
- Example 3.5: Repurchase Feature
 - Q&A 3.26: Effect of Call Features on Award Classification
 - Q&A 3.27: Effect of Buy-Back Program on Award Classification
 - Q&A 3.27a: Buy-Back of Vested Shares from Former Employees and Founders by a Nonpublic Company
 - Q&A 3.28: Effect of Call Features
 - Early Exercise of a Share Option Award
- Example 3.6: Share Awards Subject to a Repurchase Feature
 - Breach of Exemption Requirements
- Awards Settleable in a Foreign Currency
- Assessment of Substantive Terms of an Award to Determine Classification
 - Example 3.7: Classification of an Employee Award with a Potential Cash Refund on Termination Prior to Vesting
 - Examining Past Practice
 - Excerpt from ASC 718-10-55-120 through 55-130
 - Case B: Phantom Shares of Share Options
- Entity’s Ability to Exercise Its Choice
- Other Considerations
- Black-Out Periods

Example 3.8: Effect of Blackout Periods on Award Classification
Interaction between ASC Topics 480 and 718

Mandatorily Redeemable Financial Instruments

Classification Considering the Topic 480 Scope Exception

Example 3.9: Redemption of Securities

Q&A 3.29: Shares in a Partnership

Example 3.10: Mandatorily Redeemable Shares

Example 3.11: Employee Call Option over Mandatorily Redeemable Shares

Example 3.12: Employee Call Option – Redeemable Shares of a Subsidiary

Q&A 3.30: Book Value Share Purchase Plans

Contingently Redeemable Shares

Classification of Contingently Cash-Settleable Awards

Obligations Settled by Issuing a Variable Number of Shares

Example 3.13: Employee Share Awards to Be Paid in Shares

Example 3.13a: Employee Share Awards to Be Paid in Shares Based on Earnings That Exceed a Specified Threshold

Example 3.14: Employee Share Purchase Plan for a Fixed Monetary Amount

Example 3.15: *Type B* Employee Share Purchase Plan with a Look-Back Feature

Modifications to Awards

Example 3.16: Equity to Liability Modification

Classifying Share-Based Payment Arrangements Once Outside the Scope of ASC Topic 718

Q&A 3.31: Classification of Instrument When Retiree Can Retain Share Options for More Than a Short Period of Time

Q&A 3.32: Effect of Put Features on Award Classification After Employee Termination

Classification of Awards if They Become Subject to Other GAAP

Modifications to Award Instruments After Becoming Subject to Other GAAP

Interaction of ASC Topic 718 and SEC Literature

Application of ASC paragraph 480-10-S99-3A To Equity-Classified Share-Based Payment Arrangements That Contain Redemption Provisions

Impact of ASC paragraph 480-10-S99-3A on Awards That Are Redeemable or Expected to Become Redeemable

Example 3.17: Amounts Classified in Temporary Equity¹

Q&A 3.33: Presentation in Temporary Equity of Equity-Classified Award Subject to Redemption

Q&A 3.34: Determining the Amount of Temporary Equity of Equity-Classified Award Subject to Redemption

Q&A 3.35: Profits Interest Units with Contingent Put Feature

Example 3.18: Share-Based Payment Award That Is Expected to Become Redeemable
Impact of ASC paragraph 480-10-S99-3A on Contingently Cash Settleable Awards

Example 3.19: Awards Containing a Contingent Repurchase Feature – Part I

Example 3.21: Awards Containing a Contingent Repurchase Feature – Part II

Example 3.22: Awards Containing a Contingent Repurchase Feature – Part III

Example 3.22.1: Awards Containing a Contingent Repurchase Feature – Part IV
Nonvested Shares with a Contingent Cash Settlement Feature

Example 3.23: Nonvested Shares Containing a Contingent Repurchase Feature
Interaction of ASC Topic 718, SEC Literature, and ASC Subtopic 810-10

Example 3.24: Interaction of ASC Topic 718, SEC Guidance, and ASC Subtopic 810-10

3.000 Share-based payment awards can take various forms, with each one incorporating different terms and conditions. Because the accounting treatment is different for an equity-classified award compared to a liability-classified award, classifying an award into one of those categories is one of the first steps in determining the appropriate accounting for a share-based payment award.

3.001 Both categories of awards require recognition, through compensation cost, of the fair value of the award. For equity-classified awards, fair value is established at the grant date and is not re-measured. For liability-classified awards of public companies, fair value is initially measured at the grant date, but it is remeasured to current fair value at each reporting date until the award is settled. Nonpublic entities can make a policy decision to measure all liability-classified share-based payment arrangements either at fair value or at intrinsic value. Under either approach, nonpublic entities remeasure the liability-classified awards at each reporting date until settlement. Use of the fair value approach is preferable. ASC paragraphs 718-30-30-1 and 30-2, 35-3 and 35-4

3.002 The accounting for all share-based payment arrangements is required to reflect the rights conveyed to the holder and the obligations imposed on the issuer, regardless of how the arrangements are structured. Assessment of all the rights and obligations in a share-based payment arrangement and how the arrangement's terms affect the classification of the related awards will require the exercise of judgment based on consideration of the relevant facts and circumstances. Such terms are often found in the share-based payment award plan document, but also can be found in individual award agreements, employment agreements, or severance agreements. For example, an executive severance plan agreement may dictate what occurs to unvested awards on termination and those terms may be different from the individual award terms. If such agreements exist as of the grant date of the awards, consideration of the terms should be a part of the original terms of the award. If not, or if there are changes to the agreements that modify the terms of the awards after the grant date, those changes would have to be evaluated in determining whether they represent a change in classification (from equity to liability or vice versa) or another form of modification (see Section 5). ASC paragraphs 718-10-25-3 and 25-15

3.003 The classification criteria require an evaluation of the award conditions, settlement features, the substantive terms of the award, past practices of the grantor, and application of the classification criteria of ASC Topic 480, *Distinguishing Liabilities from Equity*, and other GAAP. Once the classification of an instrument is determined, the recognition and measurement provisions are applied until the instrument ceases to be subject to ASC Topic 718, *Compensation--Stock Compensation*, at which point the provisions of other GAAP will apply. ASC paragraphs 718-10-25-3, 25-6 through 25-18, 35-12 through 35-14, and 55-85

3.004 Equity or liability classification under ASC Topic 718 may not be consistent with the classification of the instrument under other GAAP. The classification of an award using the requirements of ASC Topic 718 applies as long as the grantee earned the award for goods delivered or services rendered and the award is not modified after the holder has delivered the goods or rendered the services. Additionally, some awards that are equity-classified for share-based payment purposes may still need to be reported as temporary equity by an SEC registrant following the classification requirements of ASC paragraphs 210-10-S99-1 and 480-10-S99-3A (see Paragraphs 3.091 through 3.104). (ASC paragraphs 718-10-35-13 and S99-1). ASC paragraph 480-10-S99-3A also applies to both SEC Debt Registrants and entities with debt covenants that require financial statement presentation in accordance with SEC rules and regulations.

3.005 The flowchart below summarizes the points to consider when *initially* classifying a share-based payment award as either equity or as a liability. The key to determining whether the award is liability-classified is whether the award compels the grantor to settle it by transfer of cash or other assets, whether the grantee can compel the grantor to settle by transferring cash or other assets, whether an equity settlement alternative exists, and whether options granted under an award are with respect to shares that are, themselves, classified as a liability. See additional discussion in this section.

ASC Topic 718 – Equity or Liability Classification for an Award

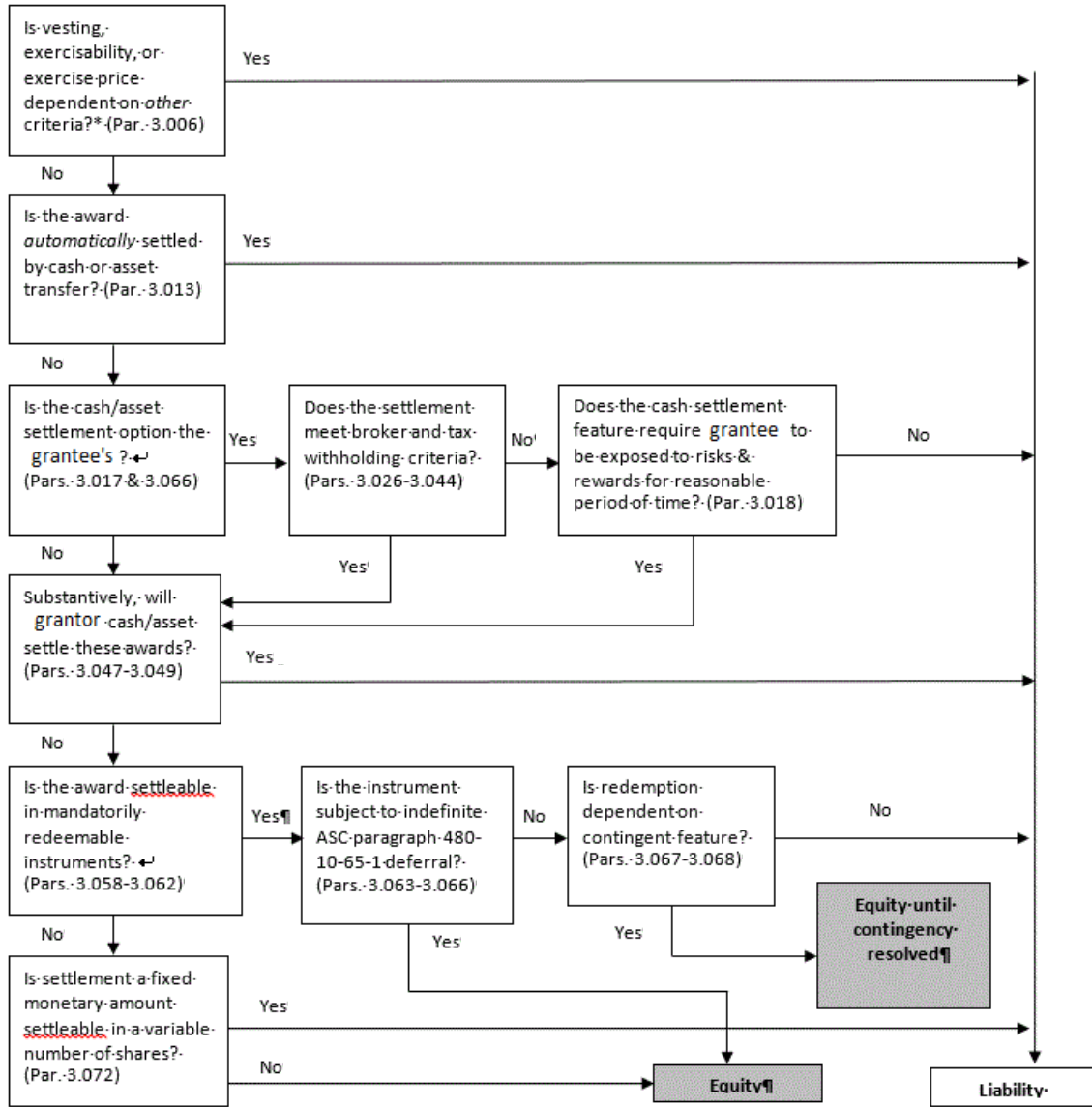

*The term other criteria refers to factors that are not market, performance, or service conditions. Paragraph numbers relate to the text in this Section.

EFFECT OF AWARD CONDITIONS ON CLASSIFICATION OTHER CONDITION

3.006 Awards may contain one or more vesting or exercisability conditions. In most cases, these conditions will be categorized as service, performance, or market conditions (see Paragraphs 2.077 to 2.084). In general, service and performance conditions affect attribution or recognition while market conditions affect the grant-date fair value of the award. A condition that does not fall into one of these three conditions is an *other* condition. Therefore, an *other* condition is one unrelated to services, performance, or

market. For example, an award in which the exercise price is linked to the price of crude oil would be an award with an *other* condition.

3.007 An award that includes an *other* condition that affects vesting, exercisability, or other factors used in measuring that award's fair value is classified as a liability. An award with this condition is considered to be *dual-indexed* and, as such, does not convey just the equity ownership relationship derived from owning a share of stock in an enterprise. This conclusion is consistent with many of the concepts contained in ASC Topic 480. ASC paragraph 718-10-25-13

3.008 Liability classification is required even when the *other* condition is related to a commodity's price and the entity is a producer or consumer of the commodity. For example, an oil and gas producer might issue awards that vest based on increases in crude oil prices (either in absolute terms, in relation to an index, or in relation to the entity's performance, such as EPS growth). Alternatively, the exercise price of a share option might be indexed to the price of crude oil. Liability classification is required even though the *other* condition is only one of the criteria (movements in the share price would be another) affecting the award's fair value.

3.009 If an *other* condition is present in the award, it is liability-classified and no further classification tests need be considered. The liability classification would be the same regardless of whether the awards are to employees or nonemployees.

3.010 Awards based on share price performance or financial performance relative to an index, or to another share, are technically dual-indexed, but in the context of ASC Topic 718, such arrangements are not deemed to cause the award to be liability-classified. A condition under which an award is exercisable if the entity's share price outperforms an index of share prices (e.g., the S&P 500) is a market condition. A condition under which an award vests if the entity's growth in EPS outperforms the EPS growth of a group of peer entities is a performance condition. Such arrangements would be equity-classified for share award purposes if they otherwise qualify as equity-classified awards. Statement 123(R), par. B128

Q&A 3.1: Award with Other Condition

Q. ABC Corp. produces and refines gold. Consequently, its profitability is significantly affected by the market price of gold. It offers employees share options in return for services and the number of share options that vest varies based on changes in the price of gold. Is the award classified as equity or a liability?

A. The award would be a liability-classified award, because the number of share options that vest is dependent on the market price of gold, which is not a market, service, or performance condition.

Q&A 3.2: Award with Other Condition--Gross National Product

Q. ABC Corp. is a diversified industrial company that manufactures and sells products in several industry sectors. Consequently, its equity-based compensation plan is tied to a broad-based measure of economic activity. The plan calls for the issuance of shares to employees if the growth rate in the company's EPS exceeds the growth rate in Gross National Product during the requisite service period. Is the award classified as equity or a liability?

A. A performance condition is defined as one that is based solely on the entity's performance or when there is a comparison of the entity's performance measure with the *same* performance measure for a group of entities. In this case, the company's performance measure (growth in EPS) is not the same measure as the comparison measure (growth in Gross National Product). As a consequence, the condition is neither a performance condition nor a service or market condition and, therefore, the award would be liability-classified.

Once the *other* condition is resolved, there would be no further impact on future exercisability and the award would be indistinguishable from an equivalent award that never contained such a condition. Therefore, ABC would reclassify the option award to equity on the vesting of the share options because the vesting provision, in this case the comparison to the GNP vesting provision, is resolved upon vesting.

Q&A 3.3: Award with Comparison to Peer Companies

Q. Assume the same facts as in Q&A 3.2, except that the award's vesting is based on a comparison of the growth in the company's EPS during the service period to the growth in the pretax income for a group of peer companies for the same period. Is the award classified as equity or a liability?

A. The performance measurement used for the company (growth in EPS) is not the same measurement that is used for the peer companies (growth in pretax income). Therefore, the condition is neither a performance condition nor a service or market condition and the award would be liability-classified.

Q&A 3.4: Award with Comparison to Peer Companies--Same Performance Measure

Q. Assume the same facts as in Q&A 3.3, except that the award's vesting is based on the growth in the company's EPS during the requisite service period exceeding the growth in EPS for a group of peer companies for the same period. Is the award classified as equity or a liability?

A. In this situation, the condition would be a performance condition because it is a comparison of the same performance measure for the company to that of its peer companies. As a consequence, assuming that the award is not otherwise liability-classified, it would be equity-classified.

Q&A 3.5: Award Indexed to Trading Volume of a Company's Stock

Q. ABC Corp. issues performance share units to its employees whereby employees will receive one share of the entity's stock for each performance share unit if the awards vest. Vesting of the units is dependent on whether the average daily trading volume of shares of ABC's common stock exceeds a specific threshold during the requisite service period. Is the award classified as equity or a liability?

A. The target referenced to the trading volume of ABC's common stock meets the definition of a performance condition because trading volume is considered to be a measure that is based on the entity's activities, similar to obtaining regulatory approval to market a specified product, obtaining a specified market share for the entity's products, selling shares in an initial public offering, or other liquidity event. Because the condition is a performance condition and the award otherwise would be equity-classified (settlement is in shares of ABC's common stock), the award would be equity-classified assuming all of the other criteria for equity classification are met.

Q&A 3.5a: Award with Scope 3 Emissions Target

Q. ABC Corp. grants share options to senior executives. As part of its net-zero strategy, it structures the arrangement so the awards vest after three years of service and upon satisfying a specified emissions reduction target. Is the award classified as equity or a liability?

Scenario 1

Emissions reduction target: Awards vest if ABC reduces its scope 3, category 1 (purchased goods and services) emissions by 25% between January 1, Year 1 and January 1, Year 4.

Throughout Years 1 and 2, ABC evaluates existing agreements with its fabric mills, garment manufacturers and other product and service suppliers. To evaluate its scope 3 category 1 emissions, ABC requests information about its suppliers' scope 1 and 2 emissions through steps including inquiries with their management, site inspections and reviews of available financial and sustainability reporting.

By December 31, Year 2 ABC has:

- renegotiated three supplier agreements to include emissions reduction commitments with penalties for nonperformance;
- terminated two agreements; and
- entered into two agreements with new suppliers.

Based on its evaluation, ABC determines that it has objective evidence to support what constitutes its scope 3, category 1 emissions. Further, ABC determines that because it controls whether it purchases goods or services from a supplier, and the extent to which it purchases goods or services from a particular supplier, the emissions are solely related to activities of ABC through its purchasing decisions.

A. In this scenario, the vesting condition meets the definition of a performance condition and, as there are no other factors that would require liability classification, the awards are accounted for as equity-classified.

Scenario 2

Emissions reduction target: Awards vest if ABC reduces its scope 3, category 7 (employee commuting) emissions by 25% between January 1, Year 1 and January 1, Year 4.

ABC implements policies to encourage its employees to reduce commuting emissions, including:

- allowing employees to work from home when possible;
- carpooling incentives; and
- identifying lower emissions travel options for those commuting by air or rail.

ABC also implements a mechanism to measure the impact of these policies on its employees' commuting behavior.

Based on its evaluation, ABC determines that it has objective evidence to support what constitutes its scope 3, category 7 emissions. Further, ABC determines that because it controls the policies implemented to incentivize employees to change their behavior and can objectively measure the impact of those policies on scope 3, category 7 emissions, the emissions are solely related to activities of ABC through its decisions meant to reduce employee commuting emissions.

A. In this scenario, the vesting condition meets the definition of a performance condition and, as there are no other factors that would require liability classification, the awards are accounted for as equity-classified.

See discussion in KPMG Handbook, Climate risk in the financial statements, Section 11.3 for further discussion about the facts and circumstances to evaluate whether scope 3 emissions are a performance condition or other condition.

AWARDS PERMITTING SETTLEMENT IN SHARES

3.011 Some share-based payment awards contain provisions permitting grantees to net-share settle vested share options. In a net-share settlement (sometimes referred to as stock option pyramiding, phantom stock-for-stock exercises, or cashless exercise), the grantee does not tender the exercise price of the share option in cash but, instead, the number of shares delivered by the company at exercise has an aggregate fair value equal to the intrinsic value of the share option at exercise. Under ASC Topic 718, awards allowing net-share settlement do not trigger liability classification provided that the shares and share options cannot be put to the company for cash. It also is permissible for a company to retain shares to meet the employer's statutory withholding requirements, provided that the amount withheld or the amount that may be withheld at the employee's discretion does not exceed the employee's maximum individual statutory rate in the applicable jurisdictions (see Paragraph 3.031).

Example 3.1: Awards Settled in Shares

On January 1, 20X5, ABC Corp. grants 1,000 share options to its CEO with an exercise price of \$10 that cliff vest after two years. The provisions of the award permit the CEO to withhold the number of shares with a fair value equal to the share option exercise price from shares that would otherwise be issued on exercise in lieu of paying the exercise price (i.e., net-share settlement). The share options would be equity-classified assuming all of the other criteria for equity classification are met.

On June 30, 20X7, when the shares are fully vested and the stock price is \$25, the CEO exercises all of the options. ABC issues the CEO 600 shares (aggregate intrinsic value of \$15,000 $([\$25 - \$10] \times 1,000 \text{ share options}) / \text{stock price of } \$25 = 600 \text{ shares}$).

3.012 If the award requires or permits settlement in shares, its classification is not affected by the manner in which the company obtains the shares needed to satisfy an award. For example, if an entity needed to acquire treasury shares on the open market to meet its requirement to deliver shares on exercise of the share option, the award would be equity-classified if it otherwise meets the requirements for equity classification. The fact that the company will pay cash to existing shareholders does not affect the classification of the share award because the treasury stock transaction is separate from the share option award. The company will issue shares to employees (or nonemployees) in satisfaction of the option exercise.

AWARDS REQUIRING OR PERMITTING SETTLEMENT IN CASH

3.013 Some share-based payment awards require an entity to settle the award by transferring cash or other assets. If the entity cannot avoid the obligation to transfer cash or other assets, for example, because grantees can compel that entity to settle the award in cash or other assets, then the award generally would be a liability. In some plans, cash settlement is a design feature of the plan. One example of such an award is a cash-settled share appreciation right (SAR), under which a grantor has an obligation to pay a grantee either on demand or at a specified date an amount of cash or other assets equivalent to the increase in the entity's share price from a specified level (the intrinsic value at settlement). Other common examples of these plans include phantom stock plans and cash performance unit awards. However, cash settlement in any of these plans may not be automatic; it may be determined either by the grantee or the grantor, in which case the accounting consequences may differ. A cash settlement feature may not be obvious; substantive rights, rather than the written terms of the award, may convey the feature to the holder of the award.

Guarantees of the Value of Stock Underlying an Option Grant

3.014 Certain compensation arrangements for employee awards may be structured so that an employee's bonus is linked to the grant of share options. These compensation arrangements take various forms but typically require that the company will guarantee a minimum level of compensation if the stock price does not appreciate to a specified price at some point before the exercise date; for example, an agreement that the employer will grant an employee a share option and a cash bonus that is payable if the stock price does not increase to the guaranteed level on a specified date. This agreement may be stated separately or included within the share option grant. The amount of the cash bonus ranges from a minimum of zero if the stock price equals or exceeds the guaranteed level up to a maximum amount based on the price guarantee. If the stock price falls below the guaranteed level, the employee will receive a cash bonus equal to the number of share options times the difference between the guaranteed and actual stock price level. Under these types of arrangements, provided the cash payment is made prior to and regardless of whether the share option is exercised, the award should be accounted for as a combination plan consisting of a net-cash-settled written put option and an equity-settled written call option. The net-cash-settled put option would be accounted for as a liability-classified award. The net-share-settled call option would be equity-classified if it otherwise meets the requirements for equity classification.

Example 3.2: Guarantees of the Value of Stock

On January 1, 20X5, ABC Corp. grants 1,000 share options to its CEO with an exercise price of \$10 that cliff vest after two years. The provisions of the award provide that if the stock price does not increase to \$20 per share by the end of the vesting period the CEO will receive a cash bonus equal to the difference between the \$20 guaranteed level and the actual stock price.

ABC determined the fair value at the date of grant for the written call option (share options to purchase 1,000 shares at \$10) to be \$3 per share option. At the grant date, the fair value of the net-cash-settled written put option (net cash settlement if the share price is less than \$20) is \$2.50. Because the written put option will be net-cash-settled, it is liability-classified and will be remeasured until settlement.

On December 31, 20X7, the shares are fully vested and the stock price is \$15. Because the stock price failed to appreciate to the guaranteed level, the CEO will receive a cash bonus equal to \$5,000 ((guaranteed stock price of \$20 less the actual stock price on vesting date of \$15) × 1,000 share options).

The total compensation cost recognized during the two-year service period is:

| | |
|--|--------------------|
| Equity-classified written call option (1,000 share options × \$3) | \$ 3,000 |
| Liability-classified written put option (1,000 shares options × \$5 cash settlement) | 5,000 ¹ |
| Total compensation cost recognized | \$ 8,000 |

¹ Because the put option is liability-classified, it is remeasured throughout the period until settlement and in the aggregate, the cumulative compensation is equal to the settlement amount.

Awards Settled Partially in Cash and Partially in Shares

3.015 Some companies settle share-based payment arrangements using a combination of cash and stock. For example, a company may grant 100 share options to an employee and also commit to make an additional cash payment equal to a fixed percentage of the value of the options when exercised. Such an award is intended to cover the taxes due when the share options are exercised (i.e., a tax *gross-up* or *top-off* payment). This award can be viewed as two awards: an award of 100 equity-classified share options and an award of cash-settled share options that will be liability-classified. Despite the connection between the awards, it is appropriate to account for this arrangement as two separate awards—an equity-classified share option award and a liability-classified cash-settled award (see Q&As 3.21 and 3.22). The structure of this award differs from awards that provide for cash settlement of a portion of an award to cover more-than-permitted tax withholdings, because, in this award, the fixed rate would not be adjusted to cover changes in tax rates regardless of whether the changes are caused by changes in the executive’s personal tax position or changes in the government’s tax rates. See additional discussion beginning at Paragraph 3.031 on equity classification when there are withholdings related to an employee’s maximum individual statutory tax rate.

Exceptions to Liability Classification for *Cash-Settled Awards*

3.016 As a general rule, all awards with a cash settlement feature should be classified as liabilities. However, exceptions are made for certain *puttable shares*, features permitting tax withholding settlement up to the employee’s maximum individual statutory tax rate, features permitting cash settlement arranged through a broker, and fair value puts when

the option holder is exposed to the market value of the shares for a reasonable period of time.

PUTTABLE ARRANGEMENTS

3.017 In the context of share-based payment arrangements, *puttable shares* convey to the holder of financial instruments as part of the overall award that may require the issuer to repurchase them at a future date. Examples include, but are not limited to, fair value put options (i.e., those designed simply to provide a cash settlement facility for grantees); or put options that provide a *floor* under the value of a share-based payment award (by providing a fixed value at which shares could be put back to the entity). An entity may convey a *puttable shares* obligation in a number of ways: these features may exist within the award; separately from the main terms of the plan (but are nevertheless part of the terms of the substantive arrangement); or within the equity instruments used to settle the award (i.e., what is conventionally termed a *puttable share*). ASC paragraphs 718-10-25-9 and 25-10

EXPOSURE TO ECONOMIC RISKS AND REWARDS

3.018 Liability classification is required whenever the arrangement permits the holder of the *puttable share* award to put the shares back to the issuing entity without being exposed to the economic risks and rewards of the share for a reasonable period of time from the date the goods are delivered or the services are rendered and the shares are issued. For share options, the awards would be liability-classified if the arrangement permits the holder to put the shares obtained upon exercise without being exposed to the risks and rewards of the shares for a reasonable period of time from the date the goods are delivered or the services are rendered and the shares are issued (regardless of the length of time the share options are held from vesting until exercise). Liability classification also is required if it is likely that the entity will prevent the holder from being exposed to the economic risks and rewards of shares for a reasonable period of time. For these purposes, contingent put features (e.g., the put is exercisable in the event of a stock listing, or a change of control) do not cause liability classification unless it is probable that the contingency will be resolved within a *reasonable period of time*. ASC paragraphs 718-10-25-9 and 25-10

3.019 Liability classification for awards of *puttable shares* is not required, as long as the shares are held by a grantee for a reasonable period of time from the date the goods are delivered or the services are rendered and the shares are issued (vesting date for awards in shares; exercise date for share option awards) and the earliest date the put can be exercised and, during that time, the grantee is exposed to the economic risks and rewards of share ownership. ASC paragraphs 718-10-25-9 and 25-10

3.019a The risks and rewards considerations also may be relevant to deferred compensation arrangements in which amounts earned by an employee are invested in the stock of the employer (and must only be the stock of the employer) and the shares are later placed, at the employee's election, into a rabbi trust. In this scenario there are two separate and distinct plans, one being a share-based payment arrangement and the other

being an elective deferred compensation arrangement via a rabbi trust. The share-based payment awards are within the scope of ASC Topic 718 and equity classified, as long as the equity classification criteria are met, the shares are held by the grantee for a reasonable period of time from the vesting date to the date the shares are placed into a rabbi trust and, during that time, the grantee is exposed to the economic risks and rewards of share ownership. Once placed in the rabbi trust, the deferred compensation arrangement is accounted for under ASC Topic 710. See Paragraphs 1.042 through 1.052 for further discussions of rabbi trusts. ASC paragraphs 718-10-25-9 and 25-10

3.020 A feature that amounts to a fixed redemption amount or provides a cap or floor to the value of the award would lead to liability classification because the holder is not exposed to the gains and losses normally associated with holding the entity's equity shares (i.e., movements in the fair market value), regardless of the period of time for which the shares are required to be held. ASC paragraphs 718-20-35-7, 718-10-55-85

3.020a A repurchase feature such as a right of first refusal, call or put could lead to liability classification if the award either permits the grantee to avoid bearing the risks and rewards normally associated with holding the entity's equity shares (i.e., movements in fair market value) or it is probable that the grantor would prevent the grantee from bearing the risks and rewards normally associated with holding the entity's equity shares for a reasonable period of time (generally six months or more - see Paragraph 3.021).

REASONABLE PERIOD OF TIME

3.021 The *reasonable period of time* for which shares are required to be held after exercise of a share option and during which the grantee is exposed to the economic risks and rewards of share ownership is at least six months. (ASC paragraphs 718-10-25-9 and 25-10, Statement 123(R), par. A227) For nonpublic entities, the required holding period can be longer (see Paragraph 3.023).

3.022 Example 3.3 shows the classification of awards as a consequence of typical terms found in put features.

Example 3.3: Put Features

| Feature | Description | Award Classification |
|-----------------------|---|--|
| Fair Value Repurchase | Repurchase at fair value on the date of repurchase; a grantee would bear the risks and rewards of ownership. (A formula using a <i>floating</i> EBITDA multiple or similar measure that is expected to approximate fair value may also qualify as a fair value repurchase.) | If repurchase right is delayed until the grantee has held shares for a reasonable period of time (at least 6 months), equity-classified. If shares not required to be held for reasonable period of time, liability-classified until reasonable period of time |

| | | |
|-------------------------------|---|---|
| | | elapses, whereupon it becomes equity-classified |
| Fixed Price Repurchase | Repurchase is for a fixed dollar amount; a grantee would not bear the risks and rewards of ownership | Liability-classified for life of award |
| Fixed Premium over Fair Value | Repurchase is equal to the fair value of the shares plus a fixed premium; the grantee would bear the risks and rewards of ownership | Same as fair value (see above); however, compensation cost for the amount of the premium |
| Formula Repurchase Price | Repurchase based on something other than fair value (e.g., formula based on book value or fixed EBITDA or similar multiple) | Liability-classified, unless a nonpublic company whose shares are purchased and sold using the same formula basis as discussed in ASC paragraphs 718-10-55-131 and 55-133 |

Q&A 3.6: Effect of Put Features on Award Classification

Q. ABC Corp., a public company, issues nonvested shares to employees through a share-based payment arrangement. Upon vesting, the employees may, but are not required to, put the shares back to ABC at any time at the then-fair market value of the shares. ABC does not expect the holders of the shares to put them back to the company within the next 6 to 12 months. If an employee terminates employment after vesting, the employee has 30 days to exercise the put option. How should the award be classified?

A. Because the put is subject to continued employment, classification of the award is subject to the provisions of ASC Topic 718. This award would be liability-classified under ASC Topic 718 because the holder can put the shares immediately after the vesting date. The decision is within the holder's control, and ABC's expectations regarding the holder's intentions are not relevant to the classification of the award. After the employee holds the shares for six months after the award vests, the award becomes equity-classified because the employee would be subject to the economic risks and rewards of share ownership for a reasonable period of time. No further compensation cost would be recognized for the award once it becomes equity-classified. Note that the classification answer would be the same regardless of whether the award is an employee or nonemployee award. Refer to the discussion beginning at Paragraph 3.091 for additional classification considerations for equity-classified awards of public companies.

Q&A 3.7: Effect of Put Features on Award Classification--*Reasonable Period of Time*

Q. Assume the same facts as in Q&A 3.6, except that the employees are not able to put the shares back to the company until six months after the shares vest. How should the award be classified?

A. Because the employees are required to bear the economic risks and rewards of share ownership for a reasonable period of time (defined in ASC Topic 718 as at least six months), this put feature would not cause the award to be liability-classified. Therefore, the award would be equity-classified as of the grant date (see the discussion beginning at Paragraph 3.091 for additional classification considerations for equity-classified awards of public entities). Note that the classification answer would be the same regardless of whether the award is an employee or nonemployee award.

Q&A 3.8: Share Option with a Put Feature

Q. Assume the same facts as in Q&A 3.6, except that the award is a grant of share options rather than nonvested shares.

A. Because employees can put the shares back to ABC immediately after the exercise of the share options, the award would initially be liability-classified. The award would continue to be liability-classified until six months after the share options are exercised (assuming the employees have not exercised the put within six months after exercise). Once the employees have held the shares for six months, the award would become equity-classified because the employees would have been subject to the economic risks and rewards of share ownership for a reasonable period of time. No further compensation cost would be recognized for the award once it becomes equity-classified. Note that the classification answer would be the same regardless of whether the award is an employee or nonemployee award.

Refer to the discussion beginning at Paragraph 3.091 for additional classification considerations for equity-classified awards of public entities.

Q&A 3.9: Effect of Fixed-Price Put Features on Award Classification

Q. Assume the same facts as in Q&A 3.6, except that the award is puttable after six months at the market price of the shares on the date of vesting. How should the award be classified?

A. Because the employees can put the shares back to ABC and receive an amount equal to the market price of the shares at the vesting date, the employees are never exposed to the economic risks and rewards of share ownership (i.e., the value of their shares can go

up but the put feature establishes a floor on the value of the shares). As a consequence, regardless of any *waiting period* that exists before the put is exercisable, the award would be liability-classified. Note that the classification answer would be the same regardless of whether the award is an employee or nonemployee award.

Q&A 3.9a: Effect on Award Classification of a Noncompensatory Employee Share Purchase Plan Based on a Formula with a Repurchase Feature

Q. Company X, a privately held company, has Class B shares that are held exclusively by employees. Employees can purchase and sell Class B shares at a price equal to book value per share, which is believed to approximate fair value. Class B shares allow the employer, upon the employee retirement or termination for any cause, to repurchase the shares for cash at a price determined by using the same formula used to establish the purchase price. How should the award be classified?

A. Because the employer will repurchase the shares at the same formula price as when purchased by the employee, and the formula price approximates fair value, the transaction is not compensatory. However, the features of the award require further analysis to determine whether liability classification is required and therefore, would result in the recognition of compensation expense. Under ASC paragraph 718-10-25-9, if a repurchase feature prevents the employee from bearing the risks and rewards of equity ownership, the award is classified as a liability. In this case, because the terms of the award do not require the employee to hold the shares for a reasonable period of time (i.e., at least six months) prior to repurchase, the award is liability-classified until the six months lapse, whereon it becomes equity-classified. While liability-classified, compensation expense would be recognized as the award is marked to fair value (or the formula price in this example) each reporting period. Once the award becomes equity-classified, no additional compensation expense would be recorded as the award becomes noncompensatory at that time.

For further details related to the requirements affecting employee share purchase plans, see the discussion beginning at Paragraph 1.027 and Section 11, *Employee Share Purchase Plans*.

IMPACT OF TIMING OF APPRAISALS

Impact of Timing of Appraisals on Classification

3.023 For an award to be equity-classified, the grantee is required to be exposed to the economic risks and rewards of share ownership for a reasonable period of time that is defined in ASC Topic 718 as a period of at least six months. Share ownership begins from the date the goods are delivered or services are rendered and the shares are issued. For a public company, the fair value of the shares is readily determinable and therefore, a repurchase feature that becomes exercisable after a six-month holding period on the

shares will result in the grantee having been subject to the risks and rewards of ownership for a reasonable period of time. However, nonpublic companies will often need to have a valuation performed to determine the fair value of the shares that will be used when shares are repurchased. Because many nonpublic entities only perform these evaluations on specific dates (i.e., an annual basis) and use that value for all repurchases until the next measurement date, grantees may not be exposed to the economic risk and rewards of share ownership for at least six months, even when holding the stock for more than six months. In these situations, for grantees to have borne the risks and rewards of ownership for a reasonable period of time, grantees need to hold the stock for at least six months and the company needs to have performed a new valuation of the shares for purposes of the repurchase amounts.

Q&A 3.10: Effect of Timing of Appraisals on Classification of Awards – Part I

Q. A grantee exercises a share option award and receives shares of stock on March 31, 20X6. The grantee can put the shares back to the grantor at fair value on October 1, 20X6. The company obtains valuations as of June 30 and December 31 of each year and uses the value obtained until the next valuation date. Does the grantee bear the risks and rewards of ownership for a reasonable period of time?

A. No. In this situation, it is unlikely that one could argue that the share price does not change between valuation dates. The result is that grantees would be exposed to risks and rewards of share price movements from April 1, 20X6 to June 30, 20X6 (a period of three months) but not for subsequent changes in fair value from July 1, 20X6 to October 1, 20X6. Consequently, the award would be liability-classified until December 31. If the award is still held by the grantee, it would become equity-classified as of December 31. However, the award would be equity-classified from the grant date if: (1) a new valuation is performed six months after the shares are received or (2) the grantee is required to hold the award until the December 31 valuation is completed.

3.024 It also may be appropriate to conclude that an arrangement is equity-classified when grantees are permitted to put shares back to the company between valuation dates if the company will perform an analysis each time a put is exercised to determine whether there has been a change in fair value of the shares since the last measurement date. If the conclusion on the repurchase date is that fair value has not changed since the last measurement date, the most recent fair value may be used. However, when the next measurement occurs, the company should be able to identify the factors that occurred during the remaining period of time to the next measurement that caused the change.

Q&A 3.11: Effect of Timing of Appraisals on Classification of Awards – Part II

Q. On December 31, 20X6, a nonpublic entity grants 1,000 share options to its employees that cliff vest after two years of service. The exercise price of the share

options is the fair value of the entity's stock on December 31, 20X6. The fair value of the company's stock is determined each year as of December 31 using an external valuation. An employee exercises a share option award and receives shares of stock on January 1, 20X9. The employee can put the shares back to the entity at fair value on July 1, 20X9. On July 1, 20X9, the employee puts the shares back to the entity and it uses the external value obtained as of December 31, 20X8. Does the employee bear the risks and rewards of ownership for a reasonable period of time?

A. It depends. Equity classification may be appropriate if the entity has a policy of evaluating whether there have been significant changes in the stock value since the last valuation date. The entity would need to (1) evaluate the facts and circumstances each time an employee puts the shares back to it before agreeing to use the price of the last valuation date, and (2) make adjustments to the put price in response to changes in the business since that date to support that the holder has been subject to the risks and rewards of ownership for a reasonable period of time. If, in this situation, an entity concluded that the measurement as of December 20X8 still reflected the stock's fair value as of July 1, 20X9, then it should also identify the factors that support the conclusion that any changes in fair value that are reflected in the December 31, 20X9 appraisal (when it is obtained) occurred during the period from July 1, 20X9 to December 31, 20X9.

IMPACT OF TIMING OF APPRAISALS ON GRANT DATE

3.025 Under ASC Topic 718, the grant date is the date (1) at which a grantor and grantee reach a mutual understanding of the key terms and conditions of a share-based payment award and (2) that a grantee begins to benefit from, or be adversely affected by, subsequent changes in the price of the grantor's equity shares. For private companies, the timing of valuations performed to determine fair value of the award and a delay in a company's ability to obtain the evidence of fair value as of a certain date may represent a lack of understanding of the key terms and conditions necessary to have a grant date. We believe that a company could determine that a grant date has occurred even if the company is waiting on the valuation to be completed by an outside third party, provided that fair value is determined based on the following *objective* factors:

- The appraisal results in a single estimate of fair value from a relatively narrow range of supportable values;
- The appraisal is prepared without significant involvement from management; and
- Other knowledgeable valuation professionals would arrive at the same estimate of fair value.

Q&A 3.12: Effect of Timing of Appraisals on Grant Date – Part I

Q. A nonpublic entity is a well-established publishing enterprise. On January 15, 20X7, 1,000 share options are granted to employees. The exercise price of the share options is

the fair value of the entity's stock as of January 15, 20X7. The grant-date fair value of the stock is determined based on an external valuation that will be completed on March 31, 20X7. The valuation is based on historical EBITDA and comparable industry multiples. What is the grant date?

A. The grant date could be considered January 15, 20X7. The determination of fair value appears to be based on objective factors. The fact that the valuation is based on historical EBITDA and market-based comparables suggests that there would not be significant management involvement in the determination of fair value. Because the determination of fair value is based on comparable industry multiples that are readily available as of the valuation date, knowledgeable valuation professionals would likely arrive at a similar estimate of fair value.

Q&A 3.13: Effect of Timing of Appraisals on Grant Date – Part II

Q. A start-up entity has been in operation for less than three years and its sole operations consist of the development of a unique medical device to be used in surgical procedures. Because the development of the product has not been completed, the entity has no current revenues, although its prototype design has received a favorable response from potential customers. On January 15, 20X7, 1,000 share options are granted to employees. The exercise price is the fair value of the stock as of January 15, 20X7. The grant-date fair value of the stock is determined based on an external valuation that will be completed on March 31, 20X7. The valuation is based on future cash flow projections using the entity's internal estimates of the timing of successful completion of development of the product and internal sales estimates. What is the grant date?

A. The grant date is March 31, 20X7. The determination of fair value appears to be based on more subjective factors that would indicate a March 31 grant date. The fact that the valuation is based on future cash flow projections for a start-up entity that were developed by management would suggest that there would be significant management involvement in determining fair value. The fact that this entity operates in a unique market would suggest that knowledgeable valuation professionals could arrive at a wide range of estimates of fair value.

BROKER-ASSISTED CASHLESS EXERCISE

3.026 A cashless exercise involves the simultaneous exercise of a share option and sale of the shares through a broker (commonly referred to as a broker-assisted cashless exercise). Provisions for grantees to effect a cashless exercise of their share options through a broker that is not a related party of the entity do not result in liability classification for instruments that otherwise would be classified as equity, as long as the cashless exercise requires a valid exercise of the share options and the grantee is the legal owner of the shares subject to the share option. It is possible for the grantee to be the legal owner even though the grantee has not paid the exercise price to the entity prior to the sale of the shares subject to the stock option. ASC paragraph 718-10-25-16

3.027 The following criteria for equity classification for a broker-assisted cashless exercise are included in the definition of “broker-assisted cashless exercise” in the Master Glossary of the FASB Codification. They should be considered in determining whether an award meets the conditions for equity classification in ASC Topic 718:

- The grantee authorizes the exercise of a share option and (as legal owner thereof) the immediate sale of the shares;
- On the same day, the entity notifies the broker of the sale order;
- The broker executes the sale and notifies the entity of the sales price;
- The entity determines the statutory tax-withholding requirements;
- By the settlement day (three days later), the entity delivers the stock certificates to the broker; and
- On the settlement day, the broker pays the entity for the exercise price and the withholding taxes and remits the balance of the net sales proceeds to the grantee. For a qualifying broker-assisted cashless exercise, the grantee may tender to the grantor cash in excess of maximum tax withholding requirements because that cash is coming from the grantee’s sale of shares into the market, and not from the entity itself.

Statement 123(R), par. B123

3.028 If the grantor reacquired the shares from an unrelated broker (reacquisition from a related broker is not permitted) without the broker being exposed to the economic risks and rewards of share ownership for at least the settlement period, the arrangement is deemed to have a cash settlement feature, which would result in the award being liability-classified because such an arrangement can result in the grantor being obligated to transfer cash or other assets. Statement 123(R), par. B123

OTHER CASHLESS EXERCISES

3.029 Certain share option plans permit grantees to exercise the share option by exchange of cash or previously owned shares of the company’s stock, or through a net-share settlement, more commonly referred to as an immaculate cashless exercise. These features, in and of themselves, would not result in the awards being liability-classified. This is consistent with an illustration in ASC Topic 718 of a *liability-to-equity modification* in which cash-settled SARs are modified to be net-share-settled SARs. Statement 123(R), par. B123

Q&A 3.14: Use of Immature Shares in Stock-for-Stock Exercise

Q. A company’s share option plan permits employees to exercise share options and satisfy their related statutory tax withholding requirements by exchanging previously owned shares of the company’s stock. How should the award be classified?

A. Because the award is going to be settled through issuance of company shares, the award would be equity-classified. Even in situations where the shares previously owned by the employee and used in the exchange were obtained through share option exercises within the past six months (i.e., immature shares), the awards would be equity-classified.

Unless a provision for the settlement of tax withholding in excess of the employee's maximum individual statutory tax rate (see the discussion beginning at Paragraph 3.031) through previously owned shares of the company's stock that have been held less than six months results in liability classification, the award would otherwise be classified as equity.

Q&A 3.15: Immaculate Cashless Exercise

Q. A share option plan that permits stock-for-stock exercises also permits the company to withhold from shares that otherwise would be issued a number of shares having a market value equal to the exercise price for all share options exercised (i.e., net-share settlement). For example, if the option holder had 1,000 share options with an exercise price of \$10 and the underlying shares had a market price of \$25, the company would issue the option holder 600 shares and would withhold 400 shares in the form of the exercise price ($[1,000 \times (\$25 - \$10) / \$25] = 600$ shares). This arrangement often is referred to as a cashless exercise. How should this award be classified?

A. In substance, a cashless exercise is identical to a SAR settled net in shares. Because the award is going to be settled through issuance of company shares, the award would be equity-classified with the fair value established at the grant date and not remeasured.

ADDITIONAL REQUIREMENTS FOR RELATED BROKERS

3.030 Additional conditions are placed on a related broker used to effect a cashless exercise for an award to remain equity-classified. To qualify for equity classification, a related broker is required to sell the shares into the open market on behalf of the grantee (the legal owner of the shares). The sale of the shares has to take place within the normal settlement period, which is usually three days. If the shares are sold, the grantor is not exposed to the economic risks and rewards of equity ownership. ASC paragraph 718-10-25-17

Q&A 3.16: Use of a Broker to Effect a Cashless Exercise

Q. ABC Corp., an SEC registrant that is a foreign private issuer, has arranged for an unrelated broker to provide settlement for all of its grantee share options. Some of its grantees are residents of other countries and local laws prohibit share ownership by nonresidents. Does this affect the classification of any of ABC's share awards?

A. Yes. Paragraph 718-10-25-16(b) requires that a grantee must be the legal owner of all of the shares subject to a share option. If local law prohibits certain grantees from being the legal owners of the shares, then the award to those grantees would be liability-classified from the grant date.

Q&A 3.17: Use of a Related Broker

Q. ABC Corp. has provided its employees with the ability to effect a cashless exercise of shares through a related broker, DEF Corp. DEF normally sells the shares in the open market. However, due to the volume of employee shares coming to market as a result of an employee exercising a large number of share options, ABC and DEF agree that ABC will reacquire all shares issued as a result of share option exercises during the month. Does this affect the classification of the award?

A. Yes. These awards, to the extent not already exercised, and other share awards for which a related broker will be used should be accounted for as liability-classified awards. ASC Topic 718 requires that a related broker sell the shares into the open market within three days to avoid the cashless exercise affecting award classification. In addition, this action may have consequences for all other awards in the plan if the employer establishes a pattern of repurchasing shares from the related broker.

TAX WITHHOLDING

3.031 A provision in a share-based payment award for either direct or indirect (through a net-settlement feature) repurchase of shares issued on exercise of share options to meet the employer's statutory tax withholding requirements (related to the exercise) does not result in liability classification of the award if it otherwise would be classified as equity. This allows employers to determine one rate for each jurisdiction that applies to each individual employee. To meet this exception, two conditions must be met. First, the employer must have a statutory obligation to withhold taxes on the employee's behalf. Second, the amount that is withheld, or may be withheld at the employee's discretion, cannot exceed the **maximum** individual statutory tax rates in the employees' applicable jurisdictions. If both conditions are not met, the *entire* award would be liability classified. ASC paragraphs 718-10-25-16 through 25-18

3.031a For purposes of ASC Topic 718, the maximum individual statutory tax rates are based on the applicable rates required by the relevant taxing authorities (e.g., federal, state, and local) as provided in tax law, regulations, or the authority's administrative practices. The maximum individual statutory tax rates would include the employee's share of payroll or similar taxes, and would not exceed the highest statutory tax rate in that individual's jurisdiction. The classification of the cash payment of the tax withholding to the taxing authority (where net share settlement occurs) in the Cash Flows Statement is discussed in KPMG Handbook, Statement of Cash Flows, Section 16.5. ASC paragraph 718-10-25-19A

3.032 Not used.

Q&A 3.18: Statutory Tax Withholding – Part I

Q. Would a policy of rounding up to the nearest whole number of shares or cash settling fractional shares in a net settlement of nonvested shares to meet tax withholding requirements affect the equity classification of the awards under ASC Topic 718?

A. No. While the guidance in ASC paragraphs 718-10-25-16 through 25-18 indicates that a policy of allowing employees to withhold an amount in excess of the employee's maximum individual statutory tax rate would require the award to be liability-classified, it does not provide guidance on rounding to a whole number of shares or otherwise settling fractional shares, which is inherently part of a net settlement arrangement. Consistent with guidance related to fractional shares in other areas of the accounting literature, we do not believe that rounding of shares or cash settling for fractional shares would violate the principle of ASC paragraphs 718-10-25-16 through 25-18.

Q&A 3.19: Statutory Tax Withholding – Part II

Q. Past practice of ABC Corp. is to provide net settlement for employee share option awards based on the employee's marginal tax rate. Does this affect ABC's classification of the award?

A. No. ASC Topic 718 allows equity classification for awards that include a net-settlement feature for the maximum individual statutory tax-withholding amount. Therefore, this past practice of the employer to allow net settlement at the marginal tax rate amount would not result in liability classification of the entire award from grant date, as the marginal tax rate would be at a rate that is lower than the maximum individual statutory tax withholding amount.

Q&A 3.20: Statutory Tax Withholding – Part III

Q. Can ABC Corp. apply the tax withholding rules to awards issued to a director?

A. No. Although a qualifying director may be considered an employee under ASC Topic 718, the director is not considered an employee under the IRS statutory withholding requirements. Thus, there is no statutory obligation to withhold taxes on director awards and, accordingly, the criteria to meet the exception are not met.

Q&A 3.20a: Statutory Tax Withholding – Changes in Withholdings

Q. As a result of a statutory tax withholding overpayment, ABC Corp. receives a refund from the tax authorities at year-end for a portion of the statutory tax associated with the issuance of an employee’s restricted stock award. ABC remits the refund back to the employee. Does the refund remitted back to the employee affect the classification of the related award?

A. The classification of the restricted stock award depends on how the refund is remitted back to the employee. The entire award would be liability classified if the refund is remitted to the employee in cash, as this would represent ABC repurchasing the shares from the employee for an amount in excess of the maximum statutory tax rate. The entire award would be equity classified if the refund is remitted to the employee in shares. ABC determines the total number of shares that should have been remitted to the employee on the vesting date taking into account the revised year-end tax rate that differs from the tax rate that resulted in the statutory tax withholding overpayment. The excess number of shares between the final calculation and the initial calculation would then be remitted to the employee.

3.032a Supplemental Wage Limit Considerations An entity may pay to its employees amounts outside of the employee’s regular salary (e.g., commissions and bonuses, taxable prizes, reimbursements of nondeductible moving expenses, severance payments and taxable fringe benefits). These payments are treated as supplemental wages for tax withholding purposes. Share-based payments also are generally considered supplemental wages for tax withholding purposes. Taxes withheld for supplemental wages may be at a rate that is different from the rate derived from what is withheld from the employee’s paycheck, which is normally driven by the employee’s Form W-4. The IRS allows different alternatives for determining the withholding for supplemental wages related to share-based payments.

3.032b The table below summarizes these alternatives.

| When supplemental wages are \$1 million or less and: | Employer Option 1 | Employer Option 2 |
|---|---|---|
| Identified separately from employee salary, as <i>special</i> payroll (e.g., as a bonus identified separately from regular pay wages) | Employer withholds taxes at the supplemental (flat) tax rate of 25% | Employer combines regular pay wages with supplemental wages, and withholds taxes using ordinary withholding rates calculated using the employee’s Form W-4 and the withholding tax rate tables. |

| | | |
|--|--|-----|
| Not identified separately from regular wages | Supplemental withholding rate does not apply, and employer withholds taxes based on the information provided by the employee's Form W-4 and the withholding tax rate tables. | N/A |
|--|--|-----|

3.032c If total supplemental wages for the year are greater than \$1 million, the employer would withhold taxes on the amount above \$1 million at the highest U.S. federal income tax rate; for 2016 and 2017 this rate was 39.6% and for 2018 this rate is 37%. The applicable highest U.S. federal income tax rate is used regardless of the employee's Form W-4 information. Note that this does not reflect changes in the exceptions for performance-based compensation, as result of US Tax Reform, H.R. 1, which was enacted on December 22, 2017.

Q&A 3.20aa: Employee Cash Bonus Linked to Vesting of Nonvested Shares – Part I

Q. ABC Corp. applies the supplemental tax rate of 25% to awards issued to employees, which were provided as a bonus and are considered supplemental wages. Does the use of the 25% supplemental tax rate affect ABC's classification of the award?

A. No. As long as the taxes withheld are at a rate that is at or less than the maximum individual employee tax rate of 37, ABC's classification of the award is not affected. This answer would be the same if the employer combines regular pay wages with supplemental wages, and withholds taxes using the withholding tax rate tables, as the tax tables have a maximum individual employee tax rate of 37%.

Q&A 3.20b: Employee Cash Bonus Linked to Vesting of Nonvested Shares – Part II

Q. Can ABC Corp. decide to unilaterally use a 37% tax rate for the withholdings for each of its employee's awards, which are considered supplemental wages, and have the awards qualify for equity classification?

A. Yes. ABC can unilaterally withhold at a 37% tax rate for each of its employee's awards and not affect equity classification. Some jurisdictions, however, place restrictions on an employer's ability to unilaterally withhold more than the required amounts, which may result in implementation complexities if some employees do not authorize higher-than-required withholdings.

To qualify for equity classification, the amount withheld cannot exceed the maximum statutory tax rates in the employees' applicable jurisdictions (i.e., 37% for U.S. federal income tax rates). The maximum statutory tax rates are based on the applicable rates of the relevant tax authorities and only one maximum statutory tax rate needs to be determined for all employees, not to exceed the highest statutory rate in that jurisdiction. This is the case even if that rate exceeds the highest rate that may be applicable to specific award grantees.

Q&A 3.20c: Employee Cash Bonus Linked to Vesting of Nonvested Shares – Part III

Q. ABC LLP is a partnership, and it does not have a statutory income tax withholding obligation. ABC LLP issues awards to its employees, which are considered supplemental wages. ABC LLP withholds taxes at the maximum statutory tax rate for all employees in its jurisdiction (i.e., U.S. federal income tax rate of 37%). Can ABC LLP's awards qualify for equity classification?

A. No. Because ABC LLP is a partnership that does not have a statutory income tax withholding obligation, the awards issued by ABC LLP would be liability classified. The provisions in ASC paragraph 718-10-25-18 require the employer to have a statutory obligation to withhold taxes on the employee's behalf. Any net settlement for tax withholding by partnerships and pass-through entities that do not have a statutory income tax withholding obligation, would result in liability classification of the awards.

3.033 An entity may provide for some awards to be settled in a combination of stock and cash, where the cash payment is intended to cover the recipient's tax obligations. In this situation, the stock and cash should be accounted for as two separate components. Accordingly, the stock should be classified as equity, assuming no other feature causes liability classification, with compensation cost measured at the grant-date fair value, and the cash award would be liability-classified and remeasured until settlement.

Q&A 3.21: Employee Cash Bonus Linked to Vesting of Nonvested Shares

Q. ABC Corp. grants its CEO a nonvested share award, under which ABC must pay its CEO a cash bonus equivalent to 40% of the stock's market price, to be paid at the time of vesting of the nonvested shares. This bonus is intended to provide the CEO an amount of cash sufficient to meet the personal tax liability that results from the vesting of the nonvested shares. However, the rate is fixed and would not be changed if the government changes the tax rates or the CEO's personal tax situation changes. Does this affect the classification of the nonvested share award?

A. No. This bonus feature constitutes a separate award and, therefore, is not a cash settlement feature on the nonvested share award. In this situation, the nonvested share

award would be accounted for as an equity-classified award and the bonus plan would be accounted for as a separate, liability-classified award in a manner similar to a cash-settled SAR (i.e., the fair value of the bonus award constitutes 40% of a cash-settled SAR).

Q&A 3.22: Employee Cash Bonus Linked to Exercise of a Share Option

Q. ABC Corp. grants its CEO a share option award, under which ABC must pay its CEO a cash bonus equivalent to 40% of the *share* option's exercise date intrinsic value, to be paid at the time of exercise of the share options. This bonus is intended to provide the CEO an amount of cash sufficient to meet the personal tax liability that results from the exercise of the share options. However, the rate is fixed and would not be changed if the government changes the tax rates or the CEO's personal tax situation changes. Does this affect the classification of the share option award?

A. No. Similar to the conclusions for a bonus feature linked to vesting of a nonvested share award, this bonus feature constitutes a separate award rather than a cash settlement feature on the share option award. As a consequence, the share option award would be an equity-classified award (if it otherwise meets the requirements for equity classification) and the bonus award would be accounted for as a separate, liability-classified award in a manner similar to 40% of a cash-settled SAR.

3.034 An entity may have tax withholding arrangements under its tax equalization program for expatriate employees. Under the arrangement, a hypothetical withholding rate is based on the employee's statutory tax rate that *would have been in effect* if the employee had remained in the United States. This withholding occurs irrespective of the statutory withholding rate (if any) in the foreign country. Consequently, the amount withheld from the expatriate could be greater or less than the withholding that is the equivalent of the employee's maximum statutory tax rate in the applicable jurisdictions. For share-based payment arrangements, such a tax strategy would result in the award being liability-classified for employees working in jurisdictions where the hypothetical withholdings exceed the withholdings at the employee's maximum individual statutory tax rates in the jurisdictions. In many situations, the entity may be unable to determine, as of the grant date, whether the hypothetical withholding will be an amount greater than the equivalent of the employee's maximum individual statutory rate, because it is uncertain where a particular expatriate employee will be living at the time the share option is exercised. When the entity is unable to make a determination that the hypothetical withholding will not exceed the withholding at the employee's maximum individual statutory rate, the entire award would be liability-classified. However, a tax equalization program that is based on all elements of an expatriate employee's compensation may be structured so that the award remains equity-classified, although incremental payments made would be liability-classified.

Q&A 3.23: Payments Made Pursuant to Expatriates' Tax Equalization Program

Q. ABC Corp. is a multinational company that issues share options to employees. As such, U.S. employees who receive share option grants may exercise those awards while living outside of the United States, and therefore, may be subject to the statutory withholding rate in the foreign country. ABC has established a broad-based expatriate tax equalization program whereby the company pays to, or on behalf of the employee, amounts needed to *equalize* the employee's tax to the tax amount the employee would pay if he or she lived in the United States considering all elements of compensation. Therefore, in the period the share option award is exercised, pursuant to the expatriate tax equalization program, the company pays a bonus to the employee for the incremental tax the employee incurs at the time of exercise because he or she is living outside the United States. Does the potential payment of a tax bonus pursuant to an expatriate tax equalization program that is applied broadly to all components of compensation cause the entire award to be a liability-classified share based payment award within the scope of ASC Topic 718?

A. No. Because the potential tax payment is part of an expatriate tax equalization program based on all elements of compensation, whereby an individual employee may or may not be eligible for a tax bonus at the time of exercise, depending on that employee's individual facts and circumstances at the time of exercise (including where the employee lives at the time of exercise), the tax bonus feature is not probable of being paid during the employee service period and, therefore, is not treated as a separate liability-classified award under ASC Topic 718. When an amount becomes probable of being paid, which is when the tax occurs, it would be recognized in the same manner as other payments to be made under the company's tax equalization program where the share options and the tax bonus would be treated as two separate components. The share options would be classified as equity assuming no other features caused liability accounting, while the tax bonus would be accounted for as a cash-settled stock appreciation right (a liability).

3.035 If an employee uses a broker-assisted exercise program to direct withholdings of more than the withholdings at the employee's maximum individual statutory tax rates, equity classification is not precluded as long as the broker-assisted exercise complies with the provisions of ASC Topic 718 (see Paragraphs 3.026 through 3.030). While both broker-assisted exercises and tax withholding are addressed in ASC paragraphs 718-10-25-16 through 25-18, there are separate requirements for each. As a consequence, a broker-assisted exercise can result in withholdings in excess of the employee's maximum individual statutory tax rates being remitted to the company because the company is not directly involved in the share repurchase. Rather, when a broker-assisted exercise is effected in accordance with the provisions of ASC paragraphs 718-10-25-16 through 25-18, the share repurchase is effected through the market place with the assistance of the broker using the employee's cash, rather than the employer's cash.

Q&A 3.24: Not used.

Q&A 3.25: Payment of Brokerage Commissions on Exercise of a Share Option

Q. ABC Corp. grants its CEO a share option award, under which ABC must pay the CEO a cash bonus equivalent to the amount of brokerage fees that are incurred in completing a broker-assisted cashless exercise. This bonus is intended to provide the CEO an amount of cash sufficient to offset the cost incurred to sell the shares through a broker on exercise of the share options. Does this affect the classification of the share option award?

A. No. Similar to the conclusions for a bonus feature linked to vesting of a nonvested share award (see Q&As 3.21 and 3.22), this bonus feature constitutes a separate award rather than a cash settlement feature on the share option award. As a consequence, the share option award would be an equity-classified award (if it otherwise meets the requirements for equity classification) and the bonus award would be accounted for as a separate, liability-classified award in a manner similar to a cash-settled SAR.

CALLABLE ARRANGEMENTS

3.036 A grantor (or principal shareholder) may have the right to repurchase share options or share awards from grantees. These are referred to as *callable* awards. In some cases, the repurchase feature is part of the share options or nonvested stock awards. In other situations, the repurchase feature is contained in a separate shareholders' agreement between the company and its significant shareholders or its management and employees. The agreement also could be between management and nonemployees. An award that includes a feature that gives the grantor the ability to repurchase shares from the grantee instead of the grantee selling them to a third party (i.e., a right of first refusal) is also a type of repurchase right.

3.036a Liability classification is required for share-based payment awards with call features if it is probable that the grantor would prevent the grantee from bearing the risks and rewards of ownership for a reasonable period of time (six months) from the date the share is issued. We believe that Issue 23(a) of EITF 00-23, which was nullified when Statement 123R became effective and, therefore, was not codified in ASC Topic 718, is relevant by analogy in determining whether it is probable that the grantor will prevent the grantee from bearing the risks and rewards of ownership for a reasonable period of time. Issue 23(a) of EITF 00-23 indicates that all factors, including but not limited to the following, should be considered in that determination (note that while EITF 00-23 refers to “employer”, we believe the guidance could be applied to nonemployee awards in which the employer is instead the “grantor”):

- The frequency with which the employer has called immature shares in the past;

- The circumstances under which the employer has called immature shares in the past;
- The existence of any legal, regulatory, or contractual limitations on the employer's ability to repurchase shares; and
- Whether the employer is a closely held, private company (i.e., a closely held private company may have a stated or implicit policy that shares cannot be widely held, thus indicating that the repurchase of immature shares may be expected to occur).

3.036b For call features with repurchase amounts at less than the fair value of the underlying shares (or potentially at less than fair value), Issue 23(d) of EITF 00-23 also states that there is an expectation that the repurchase feature will be exercised and variable accounting, or liability classification, is required. However, if the call feature is at an amount that is greater than the fair value of the underlying shares, an assessment should be made as to whether the call is expected to be exercised under an approach similar to the assessment under Issue 23(a).

3.037 Each reporting period, entities should assess their call arrangements to determine if there is a change in the circumstances related to the call feature. If the reassessment results in reclassifying the award from equity to liability, the reclassification should be accounted for as a modification that changes an equity-classified award to a liability-classified award as discussed in Paragraph 5.023.

3.038 The scope of Issue 23(a) of EITF 00-23 excludes repurchase features that are essentially forfeiture provisions in the form of a repurchase feature. This situation would exist when the company is required to reacquire shares for an amount equal to a share option's original exercise price if the employee terminates employment within a specified period of time. This situation would, in effect, modify the employee's requisite service period or, if a nonemployee award, the nonemployee's vesting period. For example, an employee may purchase a share of stock for \$10 (fair value) at the grant date for a combination of cash and recourse notes. The employer will repurchase the share for \$10 if the employee ceases to be an employee any time within three years of the grant date. The purpose of this repurchase feature is to permit the employee's holding period for tax purposes to begin at the grant date rather than at a later date. However, in this situation the repurchase feature functions as a forfeiture (vesting) provision. Consequently, this award would be treated as a grant of a share option that was exercised early with a three-year service period rather than as a grant of a fully vested share subject to a repurchase feature as discussed in Paragraph 3.041. See also the discussion beginning at Paragraph 3.042 for early exercise of share options.

Contingent call arrangements

3.039 In other situations, companies may grant share-based payment awards containing a repurchase feature that becomes exercisable only on the occurrence of specified future events. For example, a company's call right may become exercisable only on the employee's death or disability or employees who depart as *bad leavers*. The evaluation of

contingent events should be made on an individual grantee-by-grantee basis and reassessed each reporting period throughout the contingency period.

The below flowcharts summarize the applicable accounting guidance when the repurchase feature does not function as a forfeiture (vesting) provision (see Paragraph 3.038).

Repurchase price at fair value:

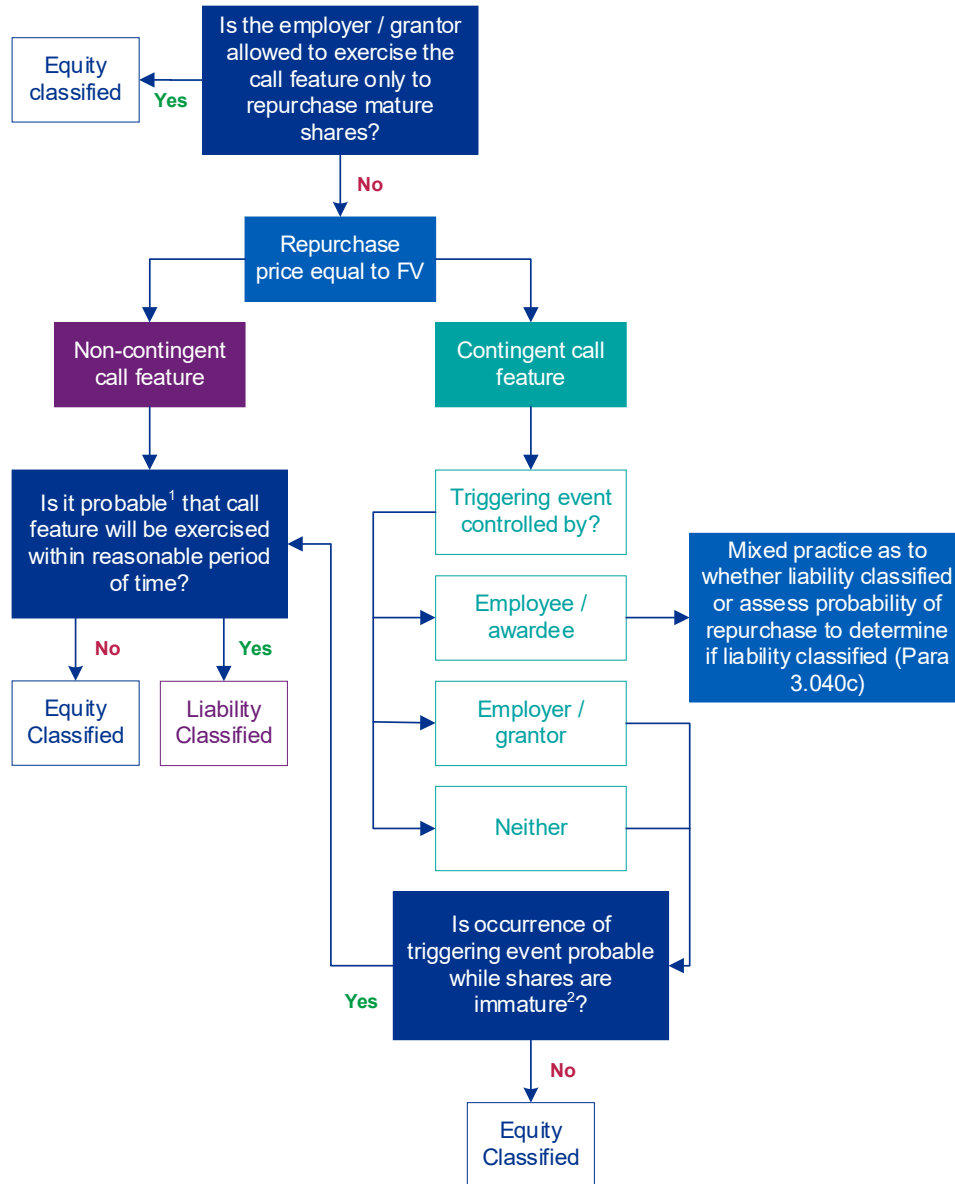

¹ Probability assessed using factors from EITF 00-23 Issue 23(a), see para 3.036.

² Probability assessment should cover the period during which the shares are immature (i.e., within six months of vesting).

Repurchase price at other than fair value:

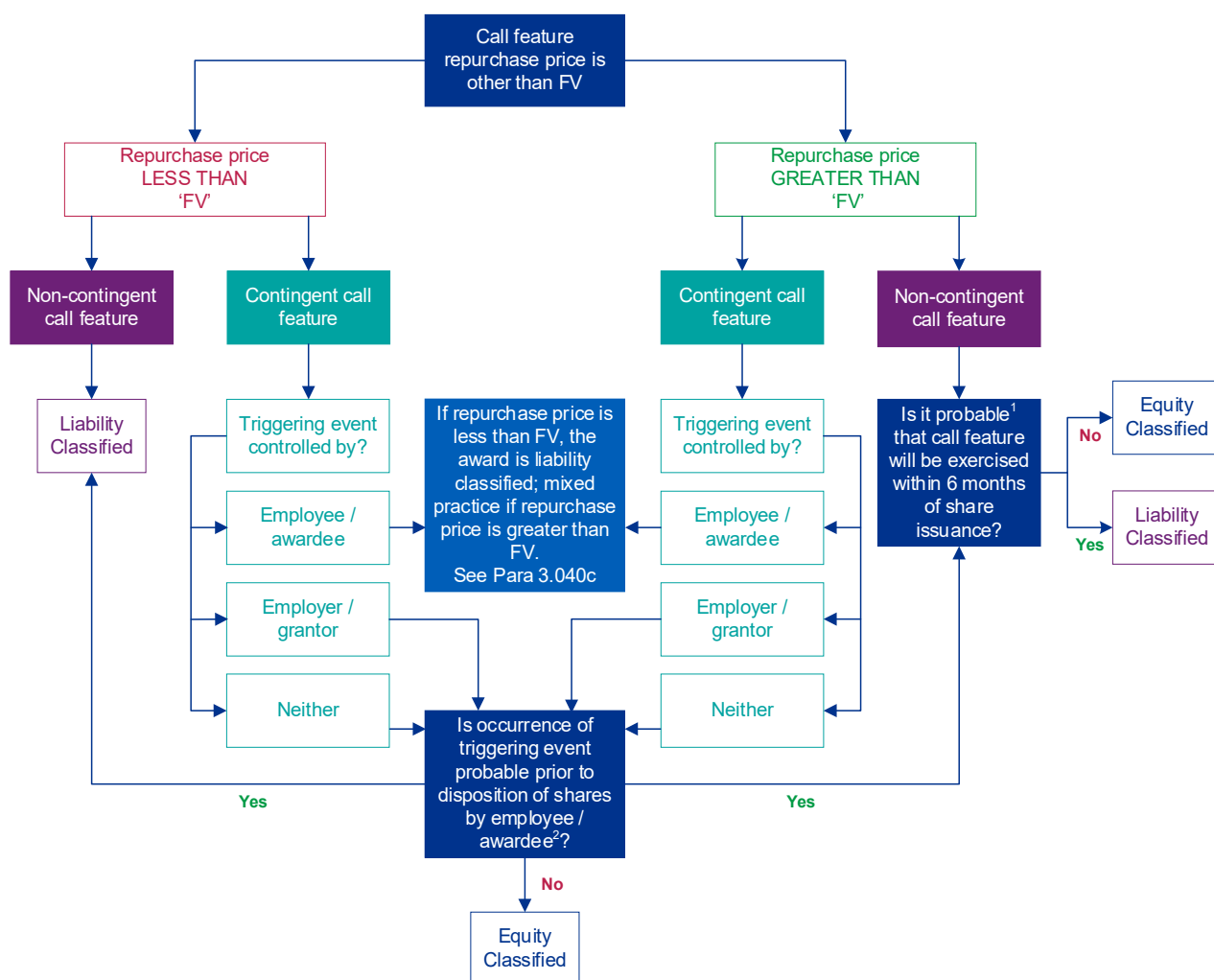

¹ Probability assessed using factors from EITF 00-23 Issue 23(a), see para 3.036a and 3.036b.

² Probability assessment should generally cover the period during which the repurchase feature is outstanding (i.e., not restricted to the 6 month maturity period).

3.040 Determining control - If the events on which a repurchase right is contingent are outside of the control of both the company and the employee (Ex. 3.4, Column A), or is within the company's control but not the employee's (Ex. 3.4, Column B), the employer should consider whether the contingent event is probable of occurring. If the occurrence of the contingent event is not probable, the award would be equity-classified, assuming it otherwise qualifies for equity classification. For the awards with contingent events outside the control of the employer and the employee (Ex. 3.4, Column A) that are issued by SEC registrants, mezzanine classification may be required on the balance sheet, as described in the discussion beginning at Paragraph 3.091.

3.040a Within the employer's control (Ex. 3.4, Column B) - In assessing the likelihood of whether a repurchase feature will be exercised by the employer (or, when the awards are granted to nonemployees, the grantor), the company should consider whether it controls the events or actions that would cause the repurchase feature to become exercisable and assess if the occurrence of such events or actions being taken is probable or not. In many of these situations, the repurchase feature may never be exercisable. A repurchase right that is within the control of the company and contingent on an event in the future, that is not currently probable will not cause an award to be liability-classified. However:

- If the repurchase is for greater than fair value: In the case when the repurchase feature within the control of the company is exercisable for an amount that is greater than fair value, the repurchase feature is not considered currently probable of being exercised and, therefore, will not cause the award to be liability-classified.
- If the repurchase is for less than fair value: If the repurchase amount is less than fair value and the occurrence of the contingent event is probable, the repurchase feature is expected to be exercised and therefore the award would be liability-classified. EITF 00-23 par. 95
- If the repurchase is at fair value: A fair value contingent call feature where the contingency is currently probable of occurring should be evaluated to determine if it is probable the company will exercise its rights before the shares are mature (i.e. held for six months).

3.040b Outside of employer and employee control (Ex. 3.4, Column A) - If the contingent event is outside the control of both the company and the employee (Ex. 3.4, Column A) and the occurrence of the contingent event is probable, the employer should evaluate whether the repurchase price is less than or greater than the fair value of the underlying shares:

- If the repurchase is for less than fair value: If the repurchase price is less than the fair value and the contingent event is probable, the repurchase is considered probable and the award will be liability-classified.
- If the repurchase is for greater than fair value: If the repurchase price is greater than the fair value, an assessment should be made as to whether the call is expected to be exercised under an approach similar to the assessment under Issue 23(a), as discussed in Paragraph 3.036a.
- If the repurchase is at fair value: A fair value contingent call feature where the contingency is currently probable should be evaluated to determine if it is probable the company will exercise its rights before the shares are mature (i.e., held for less than six months).

3.040c Within the employee's control but outside of employer control (Ex. 3.4, Column C) - There is mixed practice for events within the employee's control but outside the employer's control (Ex. 3.4, Column C) when the repurchase price is at fair

value or for greater than fair value. Some believe those awards should always be liability-classified because the employer cannot prevent the employee from taking actions within its control (e.g., terminating), and others believe the assessment should be based on a probability assessment for the repurchase. In the Exposure Draft for the simplification initiative that was ultimately finalized as part of ASU 2016-09, *Improvements to Employee Share-Based Payment Accounting*, the Board acknowledged the mixed practice and proposed a change so that events in Ex. 3.4, Column C, when the repurchase price is at fair value or for greater than fair value, should not require the awards to be liability-classified if the events were not currently probable. Comment responses were mixed on this point. The Board decided to remove this from the final ASU and decided it should be addressed as part of a larger project on distinguishing liabilities from equity. However, we believe that when the event is within the employee's control, but outside the employer's control and the repurchase price is for less than fair value, the award generally will be liability-classified as the employee is not exposed to the risks and rewards of the award. EITF 00-23 par. 96

Example 3.4: Examples of Events That Affect Repurchase Feature

| Event Outside the Control of Employer and Employee (Column A) | Event Within Employer's Control but Outside Employee's (Column B) | Event Within Employee's Control but Outside Employer's (Column C) |
|---|---|---|
| Death | Termination without cause | Voluntary termination |
| Disability | Change in control (depending on facts and circumstances) | Retirement (unless mandatory) |
| IPO | | |
| FDA Approval | | |

Example 3.5: Repurchase Feature

On January 1, 20X5, ABC Corp. grants 10,000 share options with an exercise price of \$10 that cliff vest after two years to its vice president of sales. The plan provisions provide that on departure for any reason other than for cause (voluntary, involuntary, death, disability, or retirement), the employer has the right to call outstanding shares at fair value (regardless of when they were obtained in prior exercises) and to call any remaining outstanding share options at intrinsic value. The call right exists only for a period of 30 days after termination, and if it is not exercised by ABC, the employee is permitted to retain any outstanding awards and shares, subject to the other provisions of the plan (expiration dates, vesting, etc.).

On December 31, 20X6, the share options are fully vested and on June 15, 20X7, the vice president exercises 7,500 share options. On September 1, 20X7, the vice president announces the intent to voluntarily terminate employment at the end of the month.

In this example, at the time of grant, the employee's voluntary termination or retirement are events that are within the employee's control and the call right is structured such that it could be exercised before the shares have been subject to the risks and rewards of ownership for a reasonable period of time. Under the first view described in Paragraph 3.040c, ABC would classify these instruments as a liability from the date of grant through the date they have been exercised and the shares issued are held for a reasonable period of time (i.e., six months; see Paragraph 3.023 for discussion of reasonable period of time). Under the second view described in Paragraph 3.040c, ABC would classify these instruments as equity from the date of grant through the date it becomes probable that the executive would terminate before holding the shares for six months. This would be no later than September 1, 20X7 when the vice president announced the intent to terminate. At that time, the award would be reclassified from equity to liability and a cumulative charge to earnings would be recognized for the change in fair value since the grant date.

If the employer's repurchase right instead provided that it would expire 30 days after the employee's termination subject to extension, if applicable for a particular share award, to a date after the shares had been subject to the risk and rewards of ownership for a reasonable period of time (generally six months), the award would be equity-classified, assuming that there are no other conditions that require liability classification.

Q&A 3.26: Effect of Call Features on Award Classification

Q. ABC Corp., a nonpublic company, has issued share options with a call feature that allows ABC to repurchase shares from an employee at fair value within 90 days of the employee's termination. The plan defines termination as any circumstance that qualifies as the cessation of employment with the company (e.g., voluntary or involuntary termination, death/disability or retirement). ABC has a history of repurchasing immature shares (i.e., shares owned for less than six months) from recently terminated employees. ABC is a closely held nonpublic company and does not want its equity to be widely held. How should the award be classified?

A. Some of the events on which the repurchase right is contingent are within the control of ABC, some are within the control of the employee, and some are not in the control of either party. In addition, ABC has a history of repurchasing shares of former employees at fair value, even when the shares are immature (that is, the share options are unexercised and/or the underlying shares received on exercise have not been held for a reasonable period of time (generally six months) after exercise). Further, the plan is structured so that ABC has only 90 days after termination of employment to exercise its call option.

ABC determines it is not probable it would trigger a contingency in its control (e.g., involuntary termination) and therefore ABC's accounting will depend on its policy election as described in Paragraph 3.040c. If ABC's policy is based on the first view, the combination of the historical frequency with which ABC has called immature shares and the fact that some of the termination scenarios are entirely in the employee's control suggest it is probable that ABC will repurchase the immature shares. Under that view, the outstanding share options should be liability-classified from inception until six months after the share options have been exercised. This is because it is probable that ABC would repurchase immature shares if the employee were to terminate and ABC cannot prevent the employee from terminating. If ABC's policy is based on the second view, equity classification would be permitted from the grant date. If at some future date it becomes probable that the employee will terminate, ABC would re-evaluate the classification. If at that time, the share options remain unexercised or were exercised within six months, the awards would be reclassified to liability. This would require a cumulative charge to earnings for the change in fair value since the grant date. (See also Paragraph 3.023 for further discussion of circumstances that could result in liability classification even if the awards have been held for more than six months.)

Q&A 3.27: Effect of Buy-Back Program on Award Classification

Q. Does the cash settlement of share options under a company's share buy-back program on an employee's exercise of share options cause the entire share option plan to become liability-classified?

A. If the company establishes a pattern or has an intention of cash settling share-based payment awards, a substantive liability is created for the entire plan. In evaluating a company's past practice or intentions, consideration should be given to the existence or potential creation of an active buy-back program during the period covered by the plan. Establishment of a buy-back program that results in direct settlement of the awards, generally would provide evidence of an intention to cash settle share options that previously were equity-classified, and would result in a modification of the award that changes its classification from equity to liability (see discussion beginning at Paragraph 5.021).

A provision of a buy-back program that permits a broker-assisted cashless exercise does not result in liability classification for instruments that otherwise would be classified as equity, as long as the terms of the buy-back program or broker-assisted cashless exercise do not result in liability classification (see discussion beginning at Paragraph 3.026).

Q&A 3.27a: Buy-Back of Vested Shares from Former Employees and Founders by a Nonpublic Company

Q. If a nonpublic company buys back vested shares from former employees and / or founders, is the transaction within the scope of Topic 718?

A. It depends. The entity first determines whether the vested shares being bought back were originally granted at issuance as share-based payment awards in the scope of Topic 718 or other GAAP.

To the extent vested shares bought back relate to a previously granted share-based payment award in the scope of Topic 718, the transaction is in the scope of Topic 718 and the nonpublic company determines if the buy-back involves a compensatory element by applying the secondary offering guidance (see discussion beginning at Paragraph 1.026). However, to the extent vested shares bought back do not relate to a previously granted share-based payment award, the nonpublic company considers the facts and circumstances to determine if the transaction is for the purchase of treasury shares in the scope of Subtopic 505-30.

Q&A 3.28: Effect of Call Features

Background

ABC Corp., a nonpublic company, has issued share awards to its employees with a call feature that allows ABC to repurchase shares from employees within 90 days of the respective employee's involuntary termination (i.e., termination without cause) date at an amount that is less than the fair value of the shares. ABC has no history of repurchasing immature shares (i.e., shares owned for less than six months) from employees who were terminated involuntarily. Although ABC is a nonpublic company, it is not closely held and its equity is held by different private equity investors.

Q. How should the award be classified?

A. The repurchase right is contingent on an event (involuntary termination of employees) that is within the control of ABC Corp. (Column B in Example 3.4). In addition, the repurchase right is structured such that ABC has 90 days after terminating employees to exercise its call option at a price that will be less than the fair value of the shares. As the repurchase right is within ABC's control, ABC's accounting will depend on whether involuntary terminations are probable resulting in ABC exercising its call option. Since ABC can repurchase the shares for an amount that is less than the fair value of the shares, there is an expectation that the repurchase feature will be exercised (see Paragraph 3.040a) if the likelihood of involuntary terminations is assessed as probable. Therefore, the share awards are liability-classified at the grant date.

EARLY EXERCISE OF A SHARE OPTION AWARD

3.041 Most share option plans require the option holder to vest in the share option before it can be exercised by the holder. An early exercise plan allows the option holder to exercise the share option immediately, which may give rise to a favorable tax treatment for the employee. However, plans that permit early exercise typically specify that in the event that the employee terminates service prior to the completion of a service period, the stock received from the early exercise of the share option is subject to repurchase (i.e., an employer call option). The call option typically has a strike price of the lesser of the fair value of the stock at the call date or the original exercise price. The call option is exercisable by the employer only if the employee voluntarily or involuntarily terminates employment before the end of the vesting period. On completion of the employee's requisite service period, the call option lapses.

3.042 In these arrangements, the repurchase feature essentially functions as a forfeiture provision as discussed in Paragraph 3.038. Accordingly, the early exercise of share options is not considered to be a substantive exercise for accounting purposes and the repurchase feature (i.e., contingent call option) held by the employer creates a substantive employee requisite service period for the share option award. The cash paid for the exercise price is considered to be a deposit or prepayment of the exercise price that should be recognized by the employer as a deposit liability. Because the share options are not deemed exercised for accounting purposes, the related shares are not considered outstanding shares for accounting purposes until the employee provides the requisite service. If the employee terminates employment and the employer exercises its repurchase right, the share option is deemed to have been forfeited. The employer recognizes the repayment as a repayment of the deposit liability. If the employer does not exercise its call upon the employee's termination during the employee requisite service period, the failure to exercise the employer call represents a modification of the award to accelerate its vesting. The employer would account for the modification as a *Type III* modification, and would recognize compensation cost for the modified awards based on its fair value on the modification date (and reclassify the deposit liability into additional paid-in capital (APIC)). This would be the case even if the fair value of the award on the modification date is less than the grant-date fair value. A Type III modification is discussed at Paragraph 5.015. Note that the treatment of such repurchase features would be the same regardless of whether the awards are to employees or nonemployees. This guidance is consistent with Issue 33 of EITF 00-23. Therefore, for accounting purposes:

- (1) The contingent repurchase feature provision (i.e., the call option) held by the employer functions as a forfeiture provision that preserves the original vesting schedule with respect to an employee's ability to benefit from the rewards of share ownership if the call option (a) expires at the end of the original vesting period for the share option award, (b) becomes exercisable only if a termination event occurs that would have caused the share option award to be forfeited, and (c) has a strike price of the lower of the employee's exercise price or the fair value of the underlying stock at the date the call is exercised. In other words, the early exercise causes the share option award to have characteristics in common with a nonvested stock award.

- (2) A modification of a fixed share option award to permit early exercise concurrent with the establishment of a call option does not represent the acceleration of vesting because the employee is not entitled to the rewards of ownership prior to the satisfaction of the requisite service.
- (3) Shares issued upon early exercise are not considered outstanding until the call option expires (i.e., requisite service has been provided) for purposes of computing basic EPS, because the employee is not entitled to the rewards of ownership. An entity should consider the early exercised awards as outstanding options for purposes of its ASC Topic 718 disclosures. However, if the shares are legally outstanding, they should still be included in total outstanding share disclosures as required by SEC Regulation S-X. This will result in a difference between the number of shares outstanding for accounting purposes and those disclosed on the face of the balance sheet.

Example 3.6: Share Awards Subject to a Repurchase Feature

Background

ABC Corp. is a privately held company that sells shares to certain employees at fair value. Holders of these shares are subject to a Shareholder Agreement, which provides certain call and put features on termination of employment. The terms of the Shareholder Agreement are:

| Nature of Termination | Call Price | Put Price |
|---------------------------|---|------------|
| Death or disability | Fair value | Fair value |
| Termination without cause | Fair value | Fair value |
| Termination for cause | Lesser of cost or fair value | N/A |
| Voluntary resignation | Within 2 years of grant date: Lesser of cost or fair value | N/A |
| | 2 years or more after grant date: Fair value | N/A |

ABC has a history of repurchasing the shares of employees who terminate employment, regardless of the nature of the termination and without regard to whether the shares are *mature* at the time of repurchase.

Evaluation

Even though the employee pays fair value for the shares upon grant, the terms of the award are, in substance, a share option that may be exercised prior to vesting.

The two-year call feature associated with the voluntary resignation is effectively the service period over which the awards vest (i.e., cliff vesting at the end of the two-year period). The restrictions placed on the employee limit the employee's upside potential of

owning the shares such that if the employee is terminated for cause or voluntarily resigns during the two-year period, the employee will not be entitled to increases in the value of the shares acquired (i.e., returning of the prepaid exercise price). Similar to other equity-based awards, the employee's exposure to downside risk during the service period would be captured in the valuation of the award through the volatility estimate.

The compensation cost associated with the award is measured based on the fair value of the award calculated as an employee share option, taking into consideration the effect of the interest forgone by the employee due to the prepayment of the exercise price (see discussion at Paragraph 11.007), and would be recognized over the service period.

The call feature functions as a forfeiture provision during the two-year service period, and therefore, does not affect the classification of the award. However, ABC's history of repurchasing shares during the six-month period after vesting such that the shares are not always *mature* upon repurchase may result in liability classification for these awards. See Q&A 3.26 and Q&A 3.27 for explanations of policy choices ABC could make, which could affect when and if these awards would be liability classified.

To avoid liability classification for these awards, the repurchase feature could be changed to require ABC to delay its repurchase of shares on termination of employment until the shares have been exposed to the risks and rewards of ownership for a reasonable period of time (six months as required in ASC paragraph 718-10-25-9).

BREACH OF EXEMPTION REQUIREMENTS

3.043 Failing to comply with requirements for an exemption from liability classification for an award with a cash settlement feature may have accounting consequences for awards beyond those directly affected. If a grantor fails to comply with the statutory tax withholding or broker-assisted cashless exercise requirements, the effect for financial reporting purposes depends on whether the failure is with respect to an individual award or awards, or is part of a systematic failure to follow the requirements for equity-classified awards. There are no *bright line* tests, and all relevant facts and circumstances should be considered. If a pattern of *failures* develops, we believe entities should review their equity-classified awards to determine whether other awards that are equity-classified only by virtue of such an exemption should be reclassified as liabilities.

3.044 In the event that an award or awards needs to be reclassified from equity to liability because the violations created a substantive liability, the accounting should follow the treatment for equity-to-liability modifications that are discussed beginning at Paragraph 5.021.

Awards Settleable in a Foreign Currency

3.045 An award that is payable to grantees of a foreign jurisdiction and denominated either in the functional currency of that entity or in the currency that is used for employee payroll purposes (i.e., it matches one of the two currencies) will be equity-classified if it

otherwise meets the requirements for equity classification. We believe this also applies when the employees reside in a foreign *jurisdiction*, but the parent company does not have established foreign *operations* in that foreign jurisdiction, e.g., Canadian-based parent entity grants awards to employees that reside in the United States, but the Canadian-based parent entity does not have US (therefore, foreign) operations. Equity classification is not precluded in this scenario if the awards are granted in either the functional currency of the Canadian-based parent entity, or the employee payroll currency, and the other criteria for equity classification are met. This guidance is brought forward from concepts originally established in EITF 00-23. The award would be originally valued in the currency in which it is denominated and translated to the local currency, with the difference considered a foreign currency translation adjustment. ASC paragraph 718-10-25-14 and Statement 123(R), B129; EITF 00-23, Issue No. 31

3.046 An award with an exercise price denominated in the currency of a market in which a substantial portion (which could be less than the majority) of the entity's equity securities trades does not contain a condition that is not a market, performance, or service condition. Therefore, the share-based payment award is not liability-classified if it otherwise qualifies for equity classification. For example, a parent entity whose functional and payroll currency is the Canadian dollar grants share options with an exercise price denominated in the U.S. dollar to employees of a Canadian entity. If a substantial portion of the parent entity's equity securities trades on a U.S. dollar denominated exchange, the options are not precluded from being equity-classified. Similarly, if an entity's shares are not publicly traded, we believe that an award is not precluded from being equity-classified if its exercise price is denominated in the currency in which all equity transactions are denominated. ASC paragraph 718-10-25-14A

Assessment of Substantive Terms of an Award to Determine Classification

3.047 The accounting for share-based payment plans as equity or liability awards should reflect the terms as mutually understood by the grantor and the grantee. That mutual understanding is fundamental and may depend on past practices or actions of the grantor or grantees that indicate the presence of substantive terms that are different from the written terms. The evaluation should also consider the ability of a grantor to meet its commitment to settle in shares and whether it is probable that the grantor would prevent the grantee from being exposed to the economic risks and rewards of share ownership for the reasonable period of time required for puttable share accounting. See the discussion of the accounting for puttable shares beginning at Paragraph 3.017. ASC paragraph 718-10-25-15; Statement 123(R), par. A227

Example 3.7: Classification of an Employee Award with a Potential Cash Refund on Termination Prior to Vesting

Background

ABC Corp. permits certain employees to elect to receive nonvested stock awards in lieu of a portion (up to 100%) of their annual incentive cash bonus. Employees who elect to receive nonvested stock awards in lieu of the cash bonus will receive nonvested stock with a value equal to 150% of the cash bonus amount based on ABC's stock price at that date). The awards cliff vest after three years of service. If employment is terminated (either voluntarily or involuntarily) prior to vesting, a cash payment equal to the lesser of the cash bonus amount plus interest or the fair market value of ABC's stock at the date of termination is made to the employee. Upon vesting of the nonvested shares, the cash settlement feature lapses.

Evaluation

In substance, the award has two separate components: (1) a cash bonus award that on termination of employment before the vesting of the nonvested stock award, ABC is obligated to settle the cash bonus award and (2) a nonvested stock award equal to 50% (150% - 100%) of the cash bonus amount to be settled by issuing equity instruments.

The original bonus amount is accrued as a liability during the year in which it is earned, and is subsequently treated as a *deposit liability* during the vesting period of the nonvested stock award. This portion of the award is earned due to the cash settlement provision on termination. The liability is *capped* at the original bonus amount plus accrued interest. On vesting, the bonus liability would be reclassified into equity because the cash settlement feature has lapsed and the cash bonus constitutes, in effect, a prepayment of the exercise price on 66.67% (100% / 150%) of the shares.

The nonvested stock award, equal to 50% of the cash bonus amount, is recognized as compensation cost over the three-year requisite service period.

EXAMINING PAST PRACTICE

3.048 The grantor's past practice of settling awards with multiple settlement alternatives may affect the classification of the awards, such as in a grantor's past practice of settling tandem awards. A tandem award is "an award with two (or more) components in which exercise of one part cancels the other(s)." For example, a tandem award would be one in which a grantor might achieve settlement either through the issuance of an equity instrument or through the payment of cash, but the use of either settlement method negates the other. The repeated choice of cash settlement by the grantor may establish a past practice by the grantor that affects the substantive terms of the award when determining the classification for accounting purposes.

3.049 Another example of a tandem award is one consisting of either a share option or a cash-settled SAR in which the grantor is obligated to pay cash on demand by the grantee. In this situation, the entity incurs a liability to the grantee, and the award would be liability-classified because the grantee can require the grantor to cash-settle the award. However, if the choice of settlement is the entity's, it can avoid transferring its assets by choosing to settle in stock. Therefore, the award may qualify as equity-classified. When the choice of settlement is the entity's and the entity usually settles in cash, its past practice would result in a liability classification for the award.

The following illustrative example describes employee awards, but the guidance may be applied to nonemployee awards, except that the cost attribution difference for nonemployee awards would need to be considered. An entity is required to recognize compensation cost for nonemployee awards in the same manner as if the entity had paid cash in accordance with ASC paragraph 718-10-25-2C. Additionally, there are valuation differences if an entity issues share options or similar instruments - see Section 2.007.

Excerpt from ASC 718-10-55-120 through 55-130

Case B: Phantom Shares of Share Options

55-120 This case illustrates a tandem award in which the components have different values after the grant date, depending on movements in the price of the entity's stock. The employee's choice of which component to exercise will depend on the relative values of the components when the award is exercised.

55-121 Entity T grants to its chief executive officer an immediately vested award consisting of the following two parts:

- a. 1,000 phantom share units (units) whose value is always equal to the value of 1,000 shares of Entity T's common stock
- b. Share options on 3,000 shares of Entity T's stock with an exercise price of \$30 per share.

55-122 At the grant date, Entity T's share price is \$30 per share. The chief executive officer may choose whether to exercise the share options or to cash in the units at any time during the next five years. Exercise of all of the share options cancels all of the units, and cashing in all of the units cancels all of the share options. The cash value of the units will be paid to the chief executive officer at the end of five years if the share option component of the tandem award is not exercised before then.

55-123 With a 3-to-1 ratio of share options to units, exercise of 3 share options will produce a higher gain than receipt of cash equal to the value of 1 share of stock if the share price appreciates from the grant date by more than 50 percent. Below that point, one unit is more valuable than the gain on 3 share options. To illustrate that relationship, the results if the share price increases 50 percent to \$45 are as follows.

| | Units | Exercise of options |
|----------------|--------------------------|----------------------------|
| Market value | \$ 45,000 (\$45 × 1,000) | \$ 135,000 (\$45 × 3,000) |
| Purchase price | 0 | 90,000 (\$30 × 3,000) |
| Net cash value | \$ 45,000 | \$ 45,000 |

55-124 If the price of Entity T's common stock increases to \$45 per share from its price of \$30 at the grant date, each part of the tandem grant will produce the same net cash payment (ignoring transaction costs) to the chief executive officer. If the price increases to \$44, the value of 1 share of stock exceeds the gain on exercising 3 share options, which would be \$42 [$3 \times (\$44 - \$30)$]. But if the price increases to \$46, the gain on exercising 3 share options, \$48 [$3 \times (\$46 - \$30)$], exceeds the value of 1 share of stock.

55-125 At the grant date, the chief executive officer could take \$30,000 cash for the units and forfeit the share options. Therefore, the total value of the award at the grant date must exceed \$30,000 because at share prices above \$45, the chief executive officer receives a higher amount than would the holder of 1 share of stock. To exercise the 3,000 options, the chief executive officer must forfeit the equivalent of 1,000 shares of stock, in addition to paying the total exercise price of \$90,000 ($3,000 \times \30). In effect, the chief executive officer receives only 2,000 shares of Entity T stock upon exercise. That is the same as if the share option component of the tandem award consisted of share options to purchase 2,000 shares of stock for \$45 per share.

55-126 The cash payment obligation associated with the units qualifies the award as a liability of Entity T. The maximum amount of that liability, which is indexed to the price of Entity T's common stock, is \$45,000 because at share prices above \$45, the chief executive officer will exercise the share options.

55-127 In measuring compensation cost, the award may be thought of as a combination — not tandem — grant of both of the following:

- a. 1,000 units with a value at grant of \$30,000
- b. 2,000 options with a strike price of \$45 per share.

55-128 Compensation cost is measured based on the combined value of the two parts.

55-129 The fair value per share option with an exercise price of \$45 is assumed to be \$10. Therefore, the total value of the award at the grant date is as follows.

| | | |
|---------------------------------------|----|--------|
| Units ($1,000 \times \$30$) | \$ | 30,000 |
| Share options ($2,000 \times \$10$) | | 20,000 |
| Value of award | \$ | 50,000 |

55-130 Therefore, compensation cost recognized at the date of grant (the award is immediately vested) would be \$30,000 with a corresponding credit to a share-based compensation liability of \$30,000. However, because the share option component is the substantive equivalent of 2,000 deep out-of-the-money options, it contains a derived service period (assumed to be 2 years). Hence, compensation cost for the share option

component of \$20,000 would be recognized over the requisite service period. The share option component would not be remeasured because it is not a liability. That total amount of both components (or \$50,000) is more than either of the components by itself, but less than the total amount if both components (1,000 units and 3,000 share options with an exercise price of \$30) were exercisable. Because granting the units creates a liability, changes in the liability that result from increases or decreases in the price of Entity T's share price would be recognized each period until exercise, except that the amount of the liability would not exceed \$45,000.

Entity's Ability to Exercise Its Choice

3.050 If the entity has the choice of settling the award in equity shares and has determined that it does not have either a past practice or an implied promise that would create a substantive liability, the entity also should evaluate whether it can, in fact, exercise its equity settlement option. For example, the entity may not be able to issue the shares because there may be legal or market-related constraints to the issuance of the requisite number of shares. However, there is a key difference when analyzing this point compared with instruments in the scope of other ASC Topics. For instruments in the scope of ASC Topic 718, a requirement to deliver registered shares does not in-and-of itself mean that the entity does not have the ability to deliver shares. ASC paragraph 718-10-25-15

Other Considerations

3.051 Any other considerations that might affect the substantive terms of the award should be taken into consideration in determining the classification of the award. The FASB did consider the possible effect of the doctrine of promissory estoppel,¹ which has been considered in liability recognition in other FASB pronouncements, on the classification of an award. However, the FASB decided not to explicitly incorporate that concept into ASC Topic 718 because its legal applicability to share-based payment arrangements is unclear. Statement 123(R), par. B120

Black-Out Periods

3.052 In certain circumstances, employees are not permitted to exercise awards due to regulatory or legal restrictions (e.g., failure to timely file financial information with the SEC). In cases of such black-out periods, a legal analysis of the employee's rights during the black-out period, as well as an analysis of the company's historical practice or intentions in dealing with affected employees is necessary, particularly if the awards are scheduled to expire during the black-out period. In some jurisdictions, the company may be legally obligated or may intend to cash settle the award or provide other fair value protection for awards whose exercise is precluded by the black-out. If so, the award may have been modified so that it is liability-classified. In other situations, the employer may be permitted to extend the contractual term of the share option to prevent it from expiring during the black-out period. The extension of the contractual terms of the share options

should be accounted for as a modification (see Section 5, *Modification of Awards*). In addition, in either case, a tax advisor should be consulted to determine if the modification has tax consequences to the individual holders and/or to the company. The following table discusses various scenarios that may arise in response to an extended black-out period and the consequences to the classification of the award.

Example 3.8: Effect of Blackout Periods on Award Classification

Scenario

Award Classification

Awards expiring (or scheduled to expire) during the blackout period; legal analysis concludes that company must cash settle awards.

Awards become liability-classified during the blackout period and remain so until settled or black-out is lifted.

Employees terminate and are subject to the customary period of post-employment exercise (black-out may or may not be expected to be lifted before remaining term expires).

Triggering event is termination of the employee. Need to evaluate facts and circumstances to understand employees' rights and employer's obligations. For example, if employer is obligated to extend the term of the share option until after the black-out is lifted and it is expected that the black-out will extend beyond the original expiration date, an equity-classified award has been modified.

Black-out expected to be lifted prior to expiration of share option.

No change to classification and accounting for award.

Black-out is expected to go beyond expiration of share option and the company extends the share option term prior to expiration.

Award remains equity-classified. However, it is likely that compensation cost will result because the expected term of the share option is increased by the modification to extend the share option's term. There also may be tax consequences to the company and to the employee.

Employee terminates, black-out is expected to go beyond expiration of share option and the company extends the share option term after employee termination.

Modification of the award (extending term of the award) to an award holder who is no longer an employee makes the award subject to *other GAAP* to determine its classification (see Paragraph 3.088).

INTERACTION BETWEEN ASC TOPICS 480 AND 718

3.053 Other GAAP guidance may sometimes be relevant in classifying or accounting for share-based payment arrangements. Share-based payments are not in the scope of ASC

Topic 480; nevertheless, unless Topic 718 indicates otherwise, an entity applies the classification criteria in ASC paragraphs 480-10-15-3 through 15-4 in determining whether to classify as a liability a freestanding financial instrument granted in a share-based payment transaction.

3.054 Drawing on the concepts of ASC Topic 480, the following characteristics may result in liability classification of share-based payment arrangements:

- *Certain* mandatory redemption features;
- Conditional or unconditional obligations to repurchase shares through the transfer of cash or other assets; and
- *Certain* obligations to issue a variable number of shares, under which the holder does not have the same economic interests as a holder of the issued shares of the entity. ASC paragraph 718-10-25-7, Statement 123(R), par. A225 – 227

3.055 ASC Topic 480 requires all freestanding financial instruments that require settlement by transferring assets, including those issued in the form of mandatorily redeemable shares, to be classified as liabilities. Additionally, ASC Topic 480 requires liability classification for some freestanding financial instruments that may be settled in a variable number of shares (either unconditionally or at the election of the holder). However, certain provisions of ASC Topic 480 provide for a scope exception (see Paragraph 3.063).

3.056 As a general rule, when determining the classification of an award under ASC Topic 718, options written on an instrument follow the same classification as the instrument itself. Accordingly, share options (i.e., call options) generally would be classified as equity if they are written on instruments that are classified as equity (even if only equity-classified because of the scope exception within ASC Topic 480 (see Paragraph 3.063)), unless the instruments would fail to be equity-classified under other provisions of ASC Topic 718. See also Paragraph 3.068. ASC paragraphs 718-10-25-9 through 25-12, 55-131; Statement 123(R), par. A226

3.057 Some companies' share-based payment awards entitle grantees to receive dividends paid on the underlying equity shares or dividend equivalents during the vesting period for liability-classified awards. ASC paragraph 718-10-55-45 does not address share-based payment awards that are liability-classified awards, therefore guidance in ASC Topic 480 should be used. Paragraph B62 of FASB Statement No. 150, Accounting for Certain Financial Instruments with Characteristics of both Liabilities and Equity (which was codified as ASC Topic 480), indicates that dividends paid on instruments classified as liabilities should be reflected as interest cost to be consistent with reporting those awards as liabilities. Therefore, all dividend equivalents paid on share-based payment awards that are liability-classified should be recognized as compensation cost, which is consistent with the treatment of the other changes in the value of the instrument. In this situation, there will be an offsetting change in the fair value of the award that will neutralize the effect on income from the recognition of the dividend.

Mandatorily Redeemable Financial Instruments

3.058 Mandatorily redeemable financial instruments may be used as the basis for share awards, particularly by nonpublic entities. Examples would include stock purchase plans of the type previously accounted for under EITF Issue No. 87-23, “Book Value Stock Purchase Plans,” which was nullified by ASC Topic 718, forward purchase contracts which represent an agreement to repurchase shares at a specified future date, or shares which an employer is obligated to repurchase on the death, retirement, or termination of an employee.

3.059 Under ASC Topic 480, a financial instrument issued in the form of shares is mandatorily redeemable if it embodies an unconditional obligation (i.e., an obligation that is required to be executed) requiring the issuer to redeem the instrument by transferring its assets at a specified or determinable date (or dates) or on an event certain to occur. A mandatorily redeemable financial instrument is classified as a liability unless redemption is required to occur only on the liquidation or termination of the reporting entity or the scope exception under ASC Topic 480 applies (see Paragraph 3.063). ASC paragraphs 480-10-25-4 and 25-6

3.060 Regardless of their legal form as shares, mandatorily redeemable instruments embody obligations that meet the definition of liabilities. Specifically, as a result of past transactions, the instruments contain a requirement to transfer assets of the entity at a future date, and the issuing entity does not have the discretion to avoid that transfer.

3.061 In determining if an instrument is mandatorily redeemable, all substantive terms within the instrument should be considered. A term extension option, a provision that defers redemption until a specified liquidity level is reached but does not eliminate the unconditional requirement for the issuer to redeem the instrument, or a similar provision that may delay or accelerate the timing of a mandatory redemption does not affect the classification of a mandatorily redeemable financial instrument as a liability. Redemption will still occur. ASC paragraph 480-10-25-1

3.062 Under ASC Topic 718, share awards are classified as liabilities if the underlying shares are classified as liabilities. Prior to the ASC Topic 480 scope exception (see Paragraph 3.063), all mandatorily redeemable financial instruments would have been classified as liabilities if the issuer had an unconditional obligation to redeem the instruments in exchange for cash or other assets on an event certain to occur. Originally, the only exception in ASC Topic 480 available to the general classification rule for mandatorily redeemable financial instruments applied to a redemption that was designed to arise only on the liquidation of the issuer. However, with the scope exception under ASC Topic 480, certain mandatorily redeemable instruments are classified as equity and, as a result, awards related to those instruments are classified as equity unless they fail to meet other requirements for equity classification under ASC Topic 718. ASC paragraph 718-10-25-8

CLASSIFICATION CONSIDERING THE TOPIC 480 SCOPE EXCEPTION

3.063 Difficulties with the practical application of ASC Topic 480 to some mandatorily redeemable shares, particularly for nonpublic entities that are not SEC registrants (as defined by the ASC Topic 480 scope exception; see Paragraph 3.064), led to a scope exception from the classification provisions of ASC Topic 480 for certain types of mandatorily redeemable shares. The effect of the requirements of ASC Topic 480, and the scope exception, for certain instruments issued by both SEC registrants and non-SEC nonpublic entities, are presented in Example 3.9. See also KPMG Handbook, Debt and equity financing, Section 6.2.40. Other types of financial instruments within the scope of ASC Topic 480 are unaffected by the scope exception.

3.064 Under the scope exception, SEC registrants are defined as “entities, or entities that are controlled by entities, (a) that have issued or will issue debt or equity securities that are traded in a public market (a domestic or foreign stock exchange or an over-the-counter market, including local or regional markets), (b) that are required to file financial statements with the SEC, or (c) that provide financial statements for the purpose of issuing any class of securities in a public market.” Accordingly, the provisions of ASC paragraphs 480-10-25-4 and 25-6, which are not deferred for U.S.-based SEC registrants, also apply to U.S. subsidiaries of entities with debt or equity listed in overseas public markets. The distinction between SEC registrants and nonregistrants differs from the distinction between public and nonpublic entities in ASC Topic 718. SEC registrants that only have debt securities traded in public markets are deemed nonpublic entities for the purposes of ASC Topic 718. Additionally, an entity that does not meet the definition of a public entity under ASC Topic 718 because its equity securities or those of its parent entity do not trade on a public market, nor has it made a regulatory filing in preparation for doing so, may still be an SEC registrant under the scope exception if the entity is otherwise required to file financial statements with the SEC. Example 3.9 shows the effect of the scope exception for SEC registrants, both public and nonpublic, and for nonpublic private entities.

Example 3.9: Redemption of Securities

| Circumstances Requiring Redemption | Non-SEC Registrant² Nonpublic | SEC Registrant² Public or Nonpublic |
|---|---|---|
| Liquidation – issuer | Not a liability under ASC Topic 480 | Not a liability under ASC Topic 480 |
| Liquidation – issuer is a subsidiary | Not a liability under the scope exception | Not a liability under the scope exception |

| | | |
|--|---|-----------|
| Redemption on a fixed date, for a fixed amount, or with respect to an external index | Liability under the scope exception | Liability |
| Redemption on employee retirement, death, termination, or departure ¹ | Not a liability under the scope exception | Liability |
| All other types of mandatorily redeemable instruments | Not a liability under the scope exception | Liability |

¹ For share options, a cash settlement feature in a share option award that can be exercised only on the occurrence of a contingent event that is outside the grantee's control, and is not probable of occurring, would not result in liability classification for that award. See Paragraph 3.069.

² SEC registrant as defined by the ASC Topic 480 exception. See Paragraph 3.064.

3.065 These exceptions also apply to other types of ownership interests, such as partnership interests.

Q&A 3.29: Shares in a Partnership

Q. ABC Corp. is a partnership that has issued financial instruments in the form of partnership interests that must be redeemed for cash when ABC is liquidated. Some of the partnership interests have been granted to employees under a share-based payment arrangement. The documents governing the operations of ABC (its partnership agreement, charter, etc.) do not specify a future dissolution or liquidation date or event. Is the share-based payment arrangement classified as equity or a liability?

A. The partnership interests issued by ABC are redeemable on liquidation or dissolution of the partnership. ASC paragraphs 480-10-25-4 and 25-6 indicate that a mandatorily redeemable financial instrument is classified as a liability unless the redemption is required to occur only on the liquidation or termination of the reporting entity. Therefore, under ASC Topic 480, the partnership interests are not deemed to be mandatorily redeemable. Equity classification would be appropriate even if a liquidation date had been specified. Accordingly, the award is equity-classified unless it fails to meet other requirements for equity classification under ASC Topic 718.

Example 3.10: Mandatorily Redeemable Shares

Background

ABC Corp., a nonpublic entity that is not an SEC registrant, issues shares to its employees that will be redeemed based on a formula designed to represent fair value of the shares, in the absence of a public market for its equity. Redemption of the shares would occur if the employee leaves, dies, or is involuntarily laid off or terminated by the company—an event certain to occur.

Evaluation

Under ASC paragraphs 480-10-25-4 and 25-6, the shares would ordinarily be mandatorily redeemable shares classified as liabilities, because they are redeemable upon an event certain to occur. However, although the shares are mandatorily redeemable, they are not classified as liabilities for purposes of ASC Topic 480 due to the scope exception for non-SEC registrants. Accordingly, the share award is equity-classified unless it fails to meet other requirements for equity classification under ASC Topic 718.

Had ABC been an SEC registrant, the award *would* have been classified as a liability, because the scope exception does not apply to SEC registrants without regard to whether they are public or nonpublic entities under the definition of ASC Topic 718.

Example 3.11: Employee Call Option over Mandatorily Redeemable Shares

Nonpublic ABC Corp. is not an SEC registrant. ABC issues a share option award to an employee on shares that are redeemable on events certain to occur. If the share option is exercised and the shares are issued, the shares would be classified as equity, due to the scope exception. Accordingly, equity classification is appropriate for the share options from the grant date, unless the award fails to meet other requirements for equity classification under ASC Topic 718.

Example 3.12: Employee Call Option – Redeemable Shares of a Subsidiary

Public ABC Corp.'s subsidiary issues a share option award on its shares that become redeemable only on liquidation of the subsidiary. If the share option is exercised and the shares are issued, the shares would be classified as equity because they are not liability-classified under ASC Topic 480 due to the scope exception. Accordingly, equity classification is appropriate for the share options from the grant date unless the award fails to meet other requirements for equity classification under ASC Topic 718.

3.066 Many nonpublic entities have share purchase plans that allow employees to acquire shares in the entity at book value or a formula price based on book value or earnings. These arrangements frequently require the entity to repurchase the shares at a price determined in the same manner as the purchase price when the employee terminates or retires (i.e., the shares are redeemable on an event certain to occur). Under the Topic 480 scope exception, equity classification is usually appropriate for non-SEC registrants (see Paragraph 3.064) if the awards also meet the other criteria for equity classification. However, these awards could still be liability-classified if they permit immediate repurchase on termination because the employee could avoid bearing the risks and rewards of ownership for a reasonable period of time (see Paragraph 3.021) or because of the entity's policy election for contingent repurchases (see Paragraph 3.040c).

Q&A 3.30: Book Value Share Purchase Plans

Q. ABC Corp., a nonpublic entity, offers management the ability to purchase common shares of ABC stock based on the company's current book value. After five years of employment, the employee has a put right for these shares based on the initial investment by the employee plus or minus their share of changes in retained earnings (book value formula). Other transactions in ABC's shares are not based on the book value formula. Is the share-based payment arrangement classified as equity or a liability?

A. Liability-classified, because these shares have a put based on other than fair value or the same formula amount available to other shareholders of the same class of stock. If the formula for repurchase included all changes in book value since the date of the employee's initial investment, was the same formula available to other shareholders of the same class of stock and had a requirement for the employee to bear risks and rewards of ownership for a reasonable period of time (see Paragraph 3.021), the awards would be equity-classified, assuming there were no other provisions that would require liability classification.

CONTINGENTLY REDEEMABLE SHARES

3.067 If the financial instrument embodies a conditional obligation to redeem the instrument (i.e., it requires the transfer of assets based on an event not certain to occur), it is only considered mandatorily redeemable and, therefore, a liability, once that event occurs, the condition is resolved, or the event becomes certain to occur. Until then, the instruments would be equity-classified under ASC Topic 480. Share awards related to such instruments also would be equity-classified while the underlying instruments are equity-classified unless the awards fail to meet other requirements for equity classification under ASC Topic 718. ASC paragraph 480-10-25-5

3.068 ASC Topic 718 provides that call options over mandatorily redeemable shares that are themselves equity due to the scope exception provided by ASC Topic 480 should also be classified as equity (unless they are liability-classified for another reason). See Paragraph 3.056. ASC paragraphs 718-10-25-9 through 25-11, 55-131; Statement 123(R), par. A226

Classification of Contingently Cash-Settleable Awards

3.069 ASC paragraph 718-10-25-11 states that a cash settlement feature in a share option award that can be exercised only on the occurrence of a contingent event that is outside the grantee's control, and is not probable of occurring, would not result in liability classification for that award. Examples of contingent events that may require or permit cash settlement include a change in control of the company, the employee's death or disability, a change in ownership that meets or exceeds a specified threshold (e.g., 20%), or a defined liquidity event. Consistent with related guidance in ASC Topic 480, a share-based payment award with a contingent cash-settlement feature that requires redemption of the share-based payment award only in the event that *all* equity holders' interests are redeemed would not result in the share-based payment award being classified as a liability on the event becoming probable of occurring. An event that involves the redemption of all equity holders would include the sale of a company in an all-cash transaction or a liquidation of the company.

3.070 ASC paragraph 718-10-35-15 requires companies to make an ongoing assessment of the probability of a contingent event's occurrence as long as the instrument is outstanding. If the contingent event becomes probable of occurring, the share option would become liability-classified at that date. The reclassification would be accounted for in the same way as a modification that changes an award from equity- to liability-classified (see Paragraphs 5.021 through 5.022 and Examples 5.13 and 5.14, for a discussion of the accounting when an equity-classified award becomes liability-classified). Additional compensation cost would be recognized at the modification date if the fair value of the award at that date exceeds its grant-date fair value amount. Compensation cost would be recorded to reflect subsequent increases and decreases in the fair value of the award for as long as the award remains liability-classified. However, the cumulative compensation cost recognized would never be less than the grant-date fair value of the award. If the contingent event subsequently is no longer probable of occurring, the award would be reclassified to equity at that time (see Paragraph 5.023 and Examples 5.15 and 5.16 for additional discussion of the accounting when a liability-classified award becomes equity-classified). ASC paragraph 718-10-35-15

3.071 The guidance in ASC paragraph 718-10-35-15 applies only to employee or nonemployee share options or similar instruments issued as part of share-based compensation arrangements within the scope of Topic 718, and cannot be applied, even by analogy, to other instruments outside the scope of share-based payment arrangements.

Obligations Settled by Issuing a Variable Number of Shares

3.072 ASC paragraph 480-10-25-14 requires that some arrangements that are required or may be variable-share-settled, be liability-classified. The FASB concluded that not all share-settled obligations establish the type of relationship that exists between an entity and its owners (i.e., they do not expose the holder to gains and losses in the fair value of an equity share in the same way as outright share ownership). Consequently, an award that is share-settleable based solely or predominantly on a fixed monetary amount is a liability-classified award and therefore is re-measured each reporting period until

settlement. However, the amount is not subject to discounting during the service period, and as such the re-measurement of the award will be to the same fixed amount each period. For example, an employee share purchase plan (ESPP) with a fixed discount amount (e.g., 15%), no look-back feature, and a fixed amount of employee contributions during the enrollment period (e.g., through payroll withholding during the enrollment period) would be liability-classified under ASC Topic 718 until settlement (i.e., when the shares are purchased). On settlement, the liability amount would be reclassified as equity. See also KPMG Handbook, Debt and equity financing, Section 6.6.

3.072a As noted in Paragraph 3.072, an award that is share-settleable for a fixed monetary amount is liability-classified because the award does not expose the holder to gains and losses in the fair value of an equity share in the same way as outright share ownership. This is due to applying the Topic 480 considerations around liability classification. However, the Topic 718 guidance in ASC paragraphs 718-10-55-108 and 55-109 on determining the service inception date and the grant date does not distinguish between an equity-classified and a liability-classified award. See Paragraphs 4.025 and 4.028 for further considerations on liability-classified awards and when those awards are able to meet the grant date criteria.

Example 3.13: Employee Share Awards to Be Paid in Shares

Background

An employee is granted an award that will vest over a four-year period. If the employee completes that service period, he will receive \$100,000 worth of company shares. The award will be settled in shares of common stock, and the number of shares will be calculated by dividing the \$100,000 by the fair value of the shares on the vesting date.

Evaluation

The award would be classified as a liability because it is for a fixed monetary amount settleable in a variable number of shares. The value of the award does not depend on movements in the share price of the employer; the employee will receive \$100,000 of value at vesting and is insulated from movements in the fair value of the shares.

This example describes employee awards; however, the conclusion that the awards are liability-classified would be the same if the awards were nonemployee awards.

Example 3.13a: Employee Share Awards to Be Paid in Shares Based on Earnings That Exceed a Specified Threshold

Background

An employee is granted an award on January 1, where the number of options that cliff-vest is based on ABC Corp.'s earnings. The award will be settled in shares of common

stock, and the number of shares will be calculated as follows: 10,000 options will vest for each \$1,000,000 increase in ABC Corp.'s EBITDA above \$5,000,000, with a maximum of 30,000 options.

Evaluation

For awards not within the scope of ASC 718, evaluation under ASC 480 or ASC 815 would generally result in liability classification due to variability in the settlement of the award based upon ABC's earnings. However, because the award is within the scope of ASC Topic 718, the variability in the number of options granted based on ABC Corp.'s EBITDA represents a performance condition that does not require the award to be classified as a liability. If all other criteria for equity classification are met, the award would be classified as equity.

Example 3.14: Employee Share Purchase Plan for a Fixed Monetary Amount

Background

ABC Corp. has an employee share purchase plan that permits employees to purchase shares at a discount of 15% off the market price of the shares at the purchase date (which is the end of the enrollment period). Employees enroll at the beginning of the enrollment period and specify a fixed amount of withholding during the enrollment period. The amount withheld during the enrollment period is used to purchase shares at the 15% discount at the end of the enrollment period. Assume that Employee A will have \$8,500 withheld during the enrollment period.

Evaluation

The award would be classified as a liability because it is for a fixed monetary amount settleable in a variable number of shares. The monetary value of the award is \$1,500 because Employee A will be able to purchase \$10,000 worth of stock ($\$10,000 \times 15\% + \$8,500$ withholding amount) resulting in a \$1,500 benefit to Employee A. The value of the award does not depend on movements in the share price of the employer; the employee will receive \$10,000 of value at the end of the enrollment period settleable in a variable number of shares.

3.073 Some companies have ESPPs that contain *look-back* features. Look-back features may take several forms including, but not limited to (a) applying the discount to the lower of the beginning or end-of-the-period share price, (b) multiple purchase periods with a reset mechanism, (c) multiple purchase periods with a rollover mechanism, or (d) single purchase period with variable withholdings. Look-back features serve to increase the value of the arrangement to the employee. For example, a look-back arrangement that provides for a 15% discount from the market price based on the lower of the enrollment date or purchase date market price is more valuable to the employee than an ESPP (or

share option) to purchase shares at 85% of the market price at the beginning of the period because the holder of the look-back feature is assured a benefit. If the price rises, the holder benefits to the same extent he or she would have if the exercise price was fixed at the grant date. Conversely, if the price declines during the period, the holder still receives the benefit of purchasing the shares at a 15% discount from their price at the date of exercise. An ESPP with a look-back feature would be compensatory under ASC Topic 718 because the look-back feature constitutes a share option arrangement. See additional discussion regarding the determination of whether an ESPP plan is compensatory in Paragraphs 1.027 through 1.034 and Paragraphs starting at 11.001 for discussion on the accounting for look-back options. ASC paragraphs 718-50-25-1, 55-10 and 55-11

3.074 ASC Section 718-50-55 provides guidance on methodologies that may be employed to value more complex look-back arrangements. The examples given in ASC Section 718-50-55 are characterized as Type A through Type I arrangements and valuation considerations are described beginning in Paragraph 2.165. For an ESPP that enables employees to purchase shares at a 15% discount and contains a look-back feature, the monetary value of the consideration realized by the employee at settlement depends on the company's share price. If the company's share price increased during the withholding period, the employee would benefit from the look-back feature and receive a fixed number of shares with a monetary value that varies directly with changes in the fair value of the company's shares. That is, the employee's payoff would be substantially equivalent to the payoff received by the holder of an equity-classified share option with an exercise price equal to the purchase price under the look-back feature. If the company's share price declines during the withholding period, the employee's payoff at settlement depends on the terms of the ESPP. For a plan with a 15% discount that does not limit the number of shares that may be purchased (i.e., a Type B plan), a decline in the company's share price during the withholding period would cause the employee to receive a variable number of shares at settlement with a monetary value equal to the amount of the employee's withholdings divided by 85%. For ESPPs with a 15% discount that contain a look-back feature and provide no limit on the number of shares that may be purchased, there are two mutually exclusive payoffs to the holder at settlement:

- If the company's share price on the settlement date is greater than the share price at the grant date, the holder's payoff is a fixed number of shares the value of which varies directly with changes in the fair value of the issuer's equity shares (i.e., the monetary value for each award equals the company's share price at the settlement date less 85% of the company's share price at the grant date); or
- If the share price on the settlement date is less than the share price at the grant date, the holder's payoff is a variable number of shares with a fixed monetary amount equal to the employee's withholdings divided by 85%.

3.075 At the enrollment date, it is unknown whether the company's share price will increase or decrease during the withholding period. Accordingly, it would be inappropriate to conclude that the monetary value of such an award is *predominantly* based on a fixed monetary amount known at inception (as discussed in Paragraph 3.072).

As such, the awards granted under ESPPs with a purchase price equal to the lesser of (a) 85% of the stock's market price when the share option is granted or (b) 85% of the price at exercise, should be classified as equity awards under ASC Topics 718 and 480. Additionally, determining whether an award that may be settled in a variable number of shares is predominantly based on a fixed monetary amount should be made at inception, and would not be reassessed in future periods, based on subsequent changes in the company's share price. The employee withholdings under ESPPs, however, would be classified as deposit liabilities until the company's shares are issued to its employees on settlement.

Example 3.15: Type B Employee Share Purchase Plan with a Look-Back Feature

Background

ABC Corp. administers an ESPP plan for its employees. On January 1, 20X6, when its share price is \$30, ABC offers its employees the opportunity to sign up for a payroll deduction to purchase its shares at either 85% of the stock's current price or 85% of the price at the end of the one-year period, whichever is lower. There is no limit on the number of shares that may be purchased at settlement, so this is considered a Type B plan, as defined in ASC paragraph 718-50-55-2.

For valuation purposes, the look-back share option in this example would be treated as a combination position with the following components:

- a. 0.15 of a share of nonvested stock
- b. One-year call option on 0.85 of a share of stock with an exercise price of \$30
- c. One-year put option on 0.15 of a share of stock with an exercise price of \$30

Evaluation

The look-back feature of the ESPP in this example should be equity-classified under ASC Topic 718. Although it is possible that the employees will receive a variable number of shares with a fixed monetary value equal to their withholdings divided by 85% at settlement, this will only occur if ABC's share price declines during the withholding period. If ABC's share price increases during the withholding period, employees will receive a fixed number of shares with a monetary value that varies directly with changes in the fair value of ABC's shares. At the grant date, it is unknown whether ABC's share price will increase or decrease during the withholding period. However, because equity securities have a positive long-term rate of return, it would *not* be appropriate to conclude at the enrollment date that the monetary value of the award is *predominantly* based on a fixed monetary amount known at inception. This determination is made at inception and would not be reassessed throughout the withholding period. ABC would classify the employee withholdings as deposit liabilities until its shares are issued to the employees on settlement.

MODIFICATIONS TO AWARDS

3.076 During the life of an award, an entity may cause the classification of its share-based payment awards to change from equity to liability or vice versa due to revisions to the terms of an award or changes in circumstances relevant to the classification of the award, for example a change in the likelihood of an event occurring that would require redemption of an award. When the classification of an award is changed from an equity instrument to a liability, the minimum amount of compensation cost to be recognized is the grant-date fair value of the instrument at the date it was granted, unless at the modification date the original vesting conditions are not expected to be satisfied. ASC paragraphs 718-20-35-3 and 55-126

Example 3.16: Equity to Liability Modification

Background

For several years, ABC Corp. has issued employee and nonemployee share options. To provide a low-cost settlement opportunity, ABC modifies vested options to enable the grantees to elect cash settlement at the intrinsic value of the share options at the exercise date.

Information for the awards affected

| | | |
|------------------------------------|----|-----------|
| Grant-date fair value | \$ | 1,000,000 |
| Fair value at time of modification | | 900,000 |

(Tax effects are ignored to simplify the example.)

Evaluation

The arrangement will now be classified as a liability because ABC can be required to pay cash if a grantee elects cash settlement.

Accounting

Prior to Modification

As the awards have already vested, ABC would have recognized, on a cumulative basis, \$1,000,000 of compensation cost with a corresponding increase in additional paid-in capital.

Upon Modification

No reduction in compensation cost is recognized at the modification date because the total recognized compensation cannot be less than the grant-date fair value for an award that was originally classified as equity (unless, at the date of the modification, the service

or performance conditions are not expected to be met). The previously recognized grant-date fair value of the award (\$1,000,000) is the minimum compensation cost.

The fair value of the liability at the modification date (\$900,000) is reclassified from paid-in capital to the liability resulting from the modification. Therefore, of the original \$1,000,000 recognized in additional paid-in capital, \$100,000 remains at the date of modification.

Subsequent Accounting

If the liability is ultimately settled for less than \$1,000,000, no reduction in compensation cost is recognized because compensation cost is at least equal to the grant-date fair value of the original equity-classified award with the difference included in additional paid-in capital. If the fair value (and ultimate settlement value) of the award is greater than \$1,000,000, the excess amount is recognized as compensation cost.

See the discussion on modifications that change the classification of an award from equity to liability beginning at Paragraph 5.021 for additional guidance on accounting subsequent to such a modification.

3.077 If an award is reclassified from liability to equity, the fair value of the award at the modification date plus additional incremental value of the modified award over the fair value of the liability-classified award at the date of the modification, if any is the total recognized compensation for the award. ASC paragraph 718-20-55-137

CLASSIFYING SHARE-BASED PAYMENT ARRANGEMENTS ONCE OUTSIDE THE SCOPE OF ASC TOPIC 718

3.078 ASC Topic 718 addresses classifying, measuring, and recognizing financial instruments issued as part of share-based payment arrangements in exchange for employees or nonemployees providing goods or services. The scope exclusions in other GAAP for share-based payment arrangements, such as ASC Topics 480 and 815, result from the different requirements needed to reflect compensation cost related to share-based payment arrangements during the employee requisite service period or nonemployee vesting period. ASC Topic 718 governs the classification of share-based payment arrangements after vesting and once the grantee is no longer an employee or providing goods or services, or is no longer a customer, as long as the awards were originally within the scope of ASC Topic 718 and are not modified after vesting (see further discussion in Paragraph 3.083b about a conflict in ASC Topic 718 regarding its ongoing applicability to employee awards that are modified after employment but before vesting). ASC paragraphs 718-10-25-7 and 35-9 through 35-11

3.079 A convertible instrument award granted to a nonemployee in exchange for goods or services to be used or consumed in a grantor's own operations is subject to recognition and measurement under Topic 718 throughout the life of the instrument unless the terms of the award are modified after a grantee vests in the award and is no longer providing

goods or services. ASC paragraph 718-10-35-10 and Paragraph 3.084 provides additional discussion on the classification of awards subject to other GAAP.

3.080 ASC paragraph 718-20-35-6 defines changes in a share option award in conjunction with or otherwise related to equity restructuring, that result in a change to the fair value, vesting conditions or classification of the award pre- and post- equity restructuring, to be modifications of the award. Because ASC paragraphs 718-10-35-9 through 35-11 provide the exemption from applying other literature to awards granted to employees or nonemployees under ASC Topic 718 unless the award is modified, questions were raised as to whether the modification of an award in response to an equity restructuring would cause the awards of recipients who were no longer providing goods or services or no longer employees at the time of the equity restructuring (such as retirees) to become subject to other GAAP for classification purposes.

3.081 As described in Paragraphs 5.040 through 5.046, there are three potential types of modifications related to an equity restructuring: (1) a modification to add an anti-dilution provision not made in contemplation of an equity restructuring, (2) a modification to the award that is required by the terms of the award in response to an equity restructuring, and (3) a modification to an award to add an anti-dilution provision made in contemplation of an equity restructuring. As described in Paragraphs 5.040 through 5.046, the first two modifications will generally not result in incremental compensation cost when the modification results in an equitable adjustment to the award holders, as the fair value pre- and post- equity restructuring is not changed (however, the vesting conditions and classification changes also would need to be considered to determine if modification accounting is applied). Conversely, the third type of modification will typically result in incremental compensation, as the fair value pre- and post-equity restructuring is changed.

3.082 In response to the questions about whether the modification of an award as a result of an equity restructuring would cause awards of recipients that were no longer providing goods or services (e.g. no longer an employee, nonemployee service provider or customer) at the time of the equity restructuring to become subject to other GAAP, ASC paragraph 718-10-35-10A states that

Only for purposes of paragraph 718-10-35-10, a modification does not include a change in the terms of an award if that change is made solely to reflect an equity restructuring provided that both of the following conditions are met:

- a. There is no increase in fair value of the award (or the ratio of intrinsic value to the exercise price of the award is preserved, that is, the holder is made whole) or the antidilution provision is not added to the terms of the award in contemplation of an equity restructuring.
- b. All holders of the same class of equity instruments (for example, stock options) are treated in the same manner.

3.083 In other words, under ASC paragraph 718-10-35-10A, the first two types of modifications described in Paragraph 3.081 would not cause (unvested and vested) awards held by employees or nonemployees (e.g., retirees) to become subject to other GAAP for classification purposes as long as there is no incremental value conveyed to the award holders (i.e., the award holders receive only an equitable adjustment). However, the third type of modification (addition of an anti-dilution provision in contemplation of an equity restructuring) would cause vested awards held by grantees who were no longer providing goods or services to become subject to other GAAP for classification purposes. Unvested awards subject to the third type of modification, regardless of whether employee or nonemployee awards, would be accounted for under Topic 718 (see further discussion in Paragraph 3.083b about a conflict in Topic 718 regarding its ongoing applicability to employee awards that are modified after employment but before vesting).

3.083a Once in the scope of Topic 718, the classification, measurement, attribution and modification guidance of Topic 718 is applied throughout the life of the instrument (for both employee and non-employee share-based payment awards) up until a post-vesting award modification occurs when the awardee / grantee is either:

- No longer providing goods / services as a nonemployee;
- No longer a customer; or
- No longer an employee (see further discussion in Paragraph 3.083b about a conflict in Topic 718 regarding its ongoing applicability to employee awards that are modified after employment but before vesting).

3.083b We have observed a conflict between ASC paragraphs 718-10-35-10 and 35-11 about whether a modification of a nonvested employee award that takes place after employment ceases and the former employee is no longer providing any nonemployee services would cause the award to become subject to other GAAP. ASC paragraph 718-10-35-11 indicates the modified award needs to be both vested and the grantee no longer employed for the modification to cause the award to become subject to other GAAP. In contrast, ASC paragraph 718-10-35-10 indicates that any modification of an employee award after employment (assuming the employee is not providing goods/services as a nonemployee) would cause the award to become subject to other GAAP, even if the award is not vested. However, both paragraphs state that a modification to a nonemployee award would need to take place after vesting for the award to become subject to other GAAP. Consistent with ASC paragraph 718-10-35-11, we believe a modification of an employee award after employment (see Example 4.28) but before vesting would not cause the award to become subject to other GAAP. This is because the FASB intended to align the accounting for employee and nonemployee awards, as described in the Basis for Conclusions to ASU 2018-07, *Improvements to Nonemployee Share-Based Payment Accounting*. However, given the conflict in Topic 718 there may be diversity in practice, with some entities concluding that post-employment modifications of nonvested employee awards cause those awards to become subject to other GAAP. In the absence of further authoritative guidance to resolve this conflict, we believe this view is also acceptable. ASC paragraphs 35-9 through 35-11 and BC 20

through 21 of ASU 2018-07, *Improvements to Nonemployee Share-Based Payment Accounting*

The following flowchart summarizes the applicable guidance on post-vesting modifications.

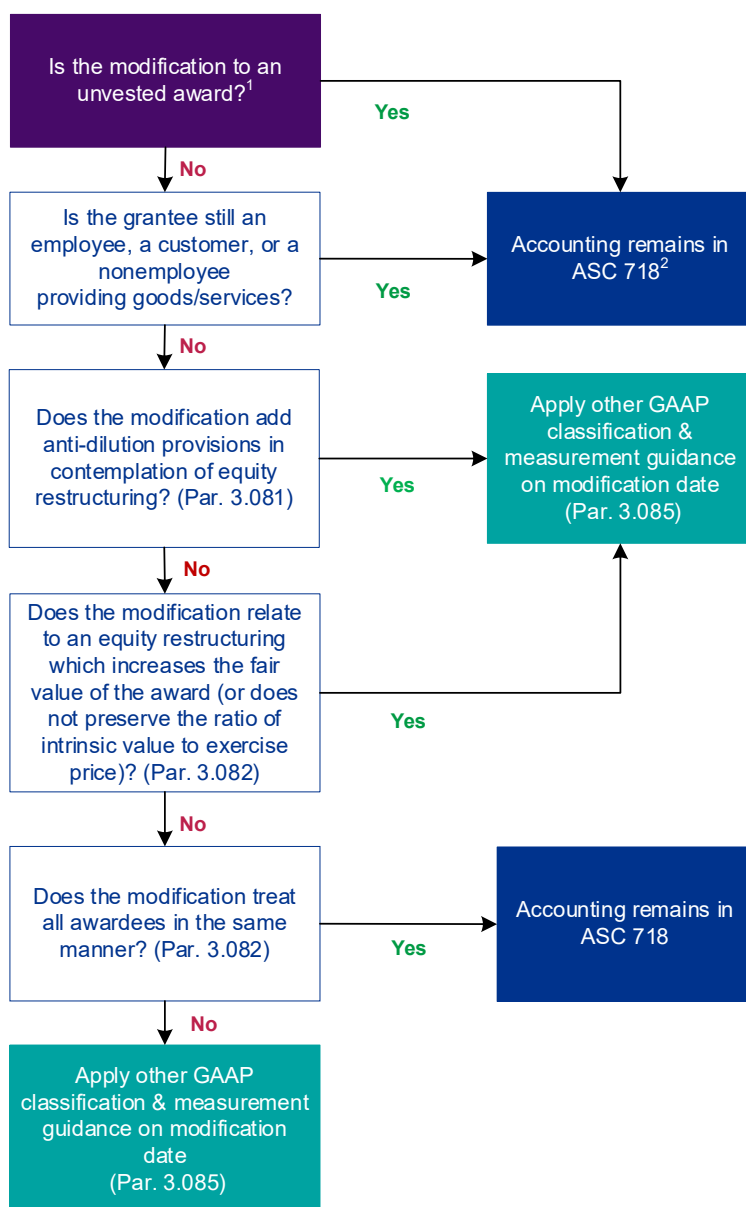

Notes:

1. Includes:

- Shares
- Stock Options
- Freestanding instruments issued as compensation
- Convertible instrument awards

2. Given the conflict in Topic 718 described in Paragraph 3.083b, there may be diversity in practice, with some entities concluding that post-employment modifications of nonvested employee awards cause those awards to become subject to other GAAP. In the absence of further authoritative guidance to resolve this conflict, we believe this view is also acceptable.

Q&A 3.31: Classification of Instrument When Retiree Can Retain Share Options for More Than a Short Period of Time

Q. ABC Corp. has granted share options to employees that vest after three years of service and have a contractual term of 10 years. When employees are eligible for retirement, they may retire with full benefits and for vested share options they have up to three years to exercise those share options. Are the share options accounted for under ASC Topic 718 or under other GAAP?

A. The share options will continue to be accounted for under ASC Topic 718 during the requisite service period and after the employees retire, unless the terms of the award are modified after the employees have retired (see Paragraph 3.084). If modified, the share options would be subject to other GAAP at different points through the contractual term of the share options.

Q&A 3.32: Effect of Put Features on Award Classification After Employee Termination

Q. ABC Corp., a public company, has issued share options to employees through a share-based payment arrangement. On exercise of the share options, the employees may, but are not required to, put the shares back to ABC at any time at the then-fair market value of the shares. If an employee terminates employment after vesting, the employee continues to have the remaining contractual term to exercise the share options. Additionally, the put option does not expire if employment terminates. How should the award be classified?

A. The award is within the scope of ASC Topic 718 and will remain so even after vesting, and even if employment terminates, as long as the award is not modified. If the employee is required to hold the shares for six months or more before they can be put back to the employer, the award could be equity-classified if it meets all other conditions for equity classification. See the discussion at Paragraph 3.040 if the employee could exercise the put option during the period before the shares have been held for six months or more.

Classification of Awards if They Become Subject to Other GAAP

3.084 In general, instruments that are equity-classified under ASC Topic 718 are either shares (e.g., nonvested shares) or share options settleable in shares. However, following the issuance of ASC paragraphs 718-10-35-9 through 35-11, a freestanding financial instrument or a convertible instrument originally issued to a grantee as a form of compensation in exchange for goods or services received (or to be received) will most likely continue to be subject to the classification, recognition, and measurement provisions of ASC Topic 718 throughout the life of instrument, unless its terms are

modified after vesting and the grantee is no longer providing goods or services, is no longer a customer, or no longer an employee (see also Paragraphs 3.083a-3.083b).

3.085 If a vested share option becomes subject to other GAAP, the instrument would be evaluated to determine whether it is within the scope of ASC Topic 815. In particular, the entity would evaluate whether the instrument is classified as equity or a liability based on the provisions of ASC Subtopic 815-40, which requires an entity to consider different factors that could result in liability classification. See chapters 8 or 8A (before and after adoption of ASU 2020-06, respectively) of KPMG Handbook, Debt and equity financing for a discussion of the requirements in ASC Subtopic 815-40.

3.086 Not used.

3.087 Under the provisions of ASC paragraphs 718-10-35-9 through 35-11, the classification of a vested share option originally granted to an employee or nonemployee would continue to be classified under ASC Topic 718. However, if the vested award is modified after a grantee is no longer providing goods or services, is no longer a customer, or is no longer an employee (e.g., a modification of the award after the holder retired from active employment), its classification and measurement become subject to the provisions of other GAAP at the date of the modification, unless the modification is related to an equity restructuring (in which the holder is made whole) that meets the conditions of ASC paragraph 718-10-35-10A (see Paragraph 3.082). If that modification causes the award to be reclassified from equity to liability at the date the vested share options are reclassified, a liability will be recognized for the then-fair value of the share option. Subsequent changes in the fair value of the instrument after it has been reclassified to liability would be included in income. ASC paragraphs 815-40-35-8 through 35-10

MODIFICATIONS TO AWARD INSTRUMENTS AFTER BECOMING SUBJECT TO OTHER GAAP

3.088 The guidance in ASC Topic 718 for modifications to share-based payment arrangements (see section 5) also applies to modifications of share-based payment awards that result from the grantee/grantor relationship after the awards are no longer subject to ASC Topic 718 for classification and measurement (i.e., grantees are no longer providing goods or services). With regard to classification and measurement after modification, as discussed in Paragraph 3.087, employee and nonemployee awards that are modified after vesting may no longer be subject to ASC paragraphs 718-10-35-9 through 35-11. Consequently, at the time the award is modified, the facts and circumstances should be considered to determine whether other GAAP applies to the award. If the modified award does not require continued service (as a nonemployee) to retain an award, then the classification and measurement of other GAAP would apply at the time the award is modified. If the modified award requires continued service (as a nonemployee) to retain an award, there is mixed practice as to when other GAAP applies. For such awards, continued classification following the guidance in ASC Topic 718 is acceptable given entities typically continue to apply the exception of ASC paragraphs 718-10-35-9 through 35-12 due to a lack of other guidance. If the award becomes liability-classified at the date

it is modified and, therefore, becomes subject to other GAAP, the modification would be accounted for in a manner similar to a modification of an award that changes its classification from equity to liability (see Paragraphs 5.021 and 5.022). ASC paragraphs 718-10-35-14, 35-10 and 35-11.

The following decision tree summarizes the guidance.

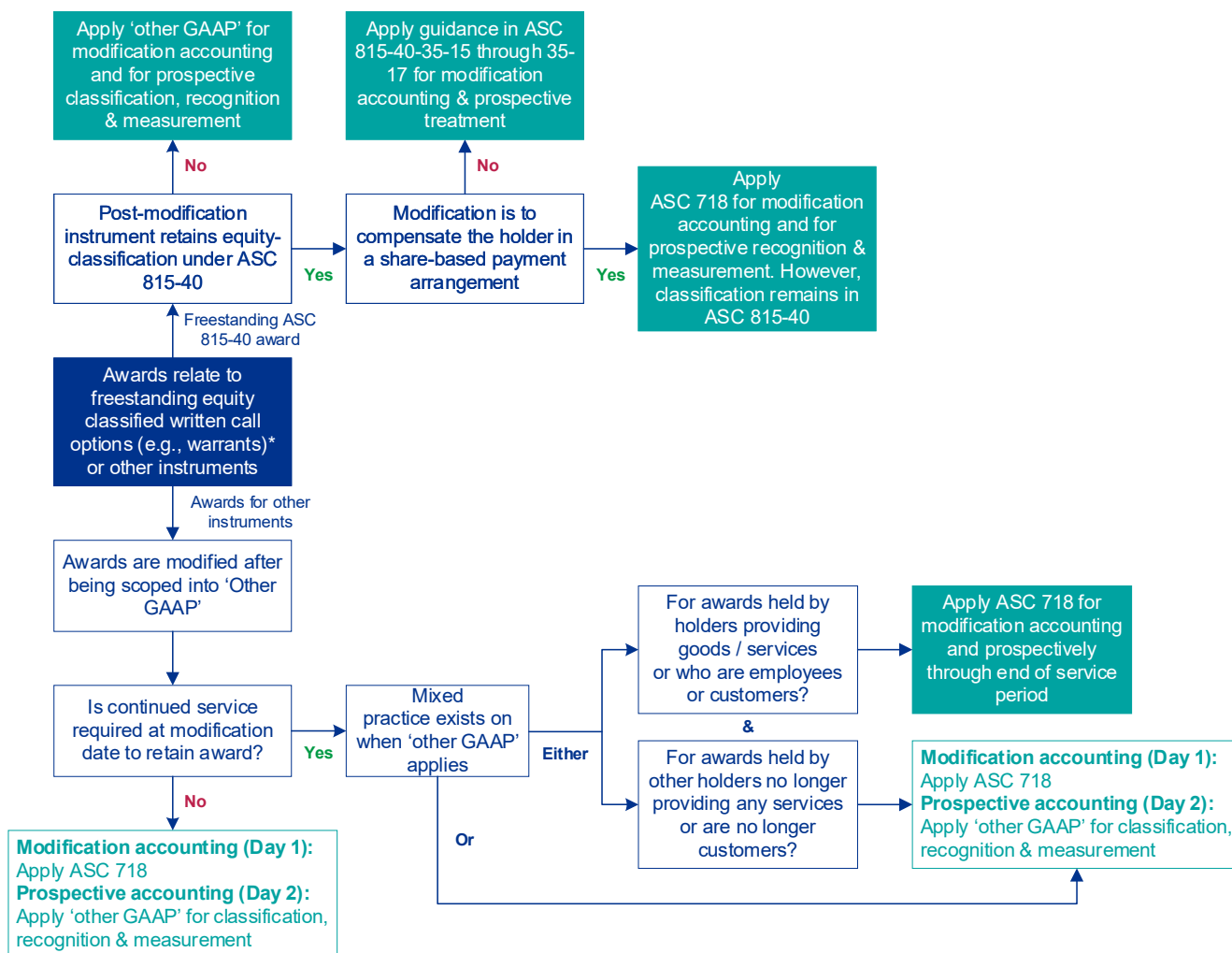

* ASC 815-40-35-14, as amended by ASU 2021-04.

3.089 A modification that does not apply equally to all financial instruments of the same class, also is treated as a share-based payment transaction to be accounted for under the requirements of ASC Topic 718. After the modification is accounted for under the guidance in ASC Topic 718, the modified instrument again reverts to the accounting under other GAAP for holders who are no longer providing goods or services or are no longer employees. ASC paragraph 718-10-35-14

3.090 If financial instruments of a particular class are held only by grantees or their beneficiaries, modifications or settlements of such financial instruments potentially stem from the employment or vendor relationship, depending on the terms of the transactions,

and thus may need to be accounted for as share-based compensation. This may occur when the common shares of an entity are wholly owned by its grantees. It also may occur if the shares underlying a share-based payment arrangement are a separate class of shares held only by grantees. ASC paragraph 718-10-35-14

3.090a In addition, while Topic 710 is considered a compensation topic (i.e., not necessarily “other GAAP”), for situations in which share-based payment arrangements accounted for under Topic 718 are replaced with awards under the scope of Topic 710, or vice versa, an entity would first apply modification accounting under Topic 718 (see Paragraphs 5.035b and c).

INTERACTION OF ASC TOPIC 718 AND SEC LITERATURE

3.091 ASC paragraph 210-10-S99-1, along with the guidance in ASC paragraph 480-10-S99-3A, requires that instruments that are classified in equity but where the issuer can be required to settle the instrument by paying cash or transferring other assets be classified outside of permanent equity. SEC registrants with instruments subject to these requirements typically present the instruments as *temporary* equity. ASC paragraphs 210-10-S99-1 and 480-10-S99-3A

3.092 When applying ASC Topic 718, equity-classified instruments that are presented as temporary equity in accordance with the SEC rules are accounted for as equity-classified awards under ASC Topic 718. ASC paragraph 718-10-S99-1 clarifies that for SEC registrants, instruments that are equity-classified under ASC Topic 718 also are subject to the presentation requirements of ASC paragraphs 210-10-S99-1 and 480-10-S99-3A. ASC paragraph 718-10-S99-1 specifies that the amount reported in temporary equity for awards that are unvested would be the redemption amount adjusted for the proportion of the employee services provided to date. ASC paragraph 718-10-S99-1

3.092a A repurchase or cash settlement feature may result in equity classification of an award under ASC Topic 718, but SEC registrants still consider the requirements of ASC paragraph 480-10-S99-1 and 480-10-S99-3A for whether the awards should be classified in temporary equity. For example:

- A grantee may have the right to require the grantor to repurchase for fair value the shares acquired on exercise of the option, beginning six months after option exercise. See Paragraphs 3.093 through 3.098.
- A share-based payment award may provide for cash settlement on an event (e.g., death, disability, or a change in control) that is not probable. See Paragraphs 3.099 through 3.103.
- An award of nonvested stock may have a contingent cash settlement feature. See Paragraph 3.104.

Application of ASC paragraph 480-10-S99-3A To Equity-Classified Share-Based Payment Arrangements That Contain Redemption Provisions

3.093 SEC registrants should apply the guidance in ASC paragraph 210-10-S99-1, which requires that redeemable preferred stock be classified outside of permanent equity. Additionally, in ASC paragraph 480-10-S99-3A, the SEC staff has stated that it believes that ASC paragraph 210-10-S99-1 should be applied to equity-classified instruments that are redeemable or will become redeemable at the election of the holder, or on the occurrence of an event that is beyond the control of the company. However, ASC paragraph 480-10-S99-3A states that ordinary liquidation events that involve the redemption and liquidation of all equity securities would not result in a security being classified outside permanent equity.

3.094 ASC paragraph 480-10-S99-3A also incorporates the guidance of ASC paragraph 718-10-S99-1 and requires that entities apply ASC paragraph 480-10-S99-3A to share-based payment arrangements concurrently with the adoption of ASC Topic 718. As such, SEC registrants need to evaluate whether the terms of instruments granted to employees as share-based payments that are not classified as liabilities under ASC Topic 718 result in the need to present certain amounts outside of permanent equity.

3.095 The amount to be classified outside of permanent equity is referred to as the *redemption amount* in ASC paragraph 480-10-S99-3A. As it applies to share-based payments, determining the redemption amount depends on whether the redemption features are:

- (1) Currently redeemable or will become redeemable based on the passage of time (see Paragraphs 3.096 through 3.098); or
- (2) Contingent on future events that are outside the control of the company (see Paragraphs 3.099 through 3.104).

Impact of ASC paragraph 480-10-S99-3A on Awards That Are Redeemable or Expected to Become Redeemable

3.096 ASC paragraph 480-10-S99-3A specifies that for equity-classified share-based payment arrangements that are currently redeemable or expected to become redeemable, the current redemption amount should be classified outside of permanent equity. Because the instrument is either currently redeemable or can become redeemable, the amount classified outside of permanent equity would be adjusted to its redemption amount at each balance sheet date.

3.097 For example, a share option award with a provision that would allow the shares underlying the share option to be redeemed for cash at fair value at the holder's option, but only after six months from the date of share issuance, would qualify for equity-classification under ASC Topic 718, provided the award would otherwise be equity-classified. However, ASC paragraph 480-10-S99-3A requires that an award with this

provision be classified outside of permanent equity because the award redemption can occur at the option of the employee (i.e., once the employee exercises the share options, the underlying shares become redeemable based on the passage of time).

3.098 Because the award is expected to become redeemable (as it is only based on passage of time), ASC paragraph 480-10-S99-3A requires that for this type of award, the amount classified outside of permanent equity be adjusted to its redemption amount at each balance sheet date. ASC paragraph 718-10-S99-1 provides additional guidance for such awards and clarifies that the amount classified outside of permanent equity is the current redemption amount, multiplied by the proportionate amount of the requisite service that has been provided by the employee as of the balance sheet date. Amounts classified outside of permanent equity for these equity-classified awards do not affect earnings available to common shareholders in EPS calculations as long as the redeemable instruments are common shares and the redemption amount is not greater than fair value.

Example 3.17: Amounts Classified in Temporary Equity¹

| Type of Instrument | Amount Classified in Temporary Equity Calculated as the Proportion of Goods Delivered or Services Rendered ² to Date Applied to: | Does the Change in Redemption Value Adjust Earnings Available to Common Shareholders ³ ? |
|---|---|---|
| Share option redeemable at intrinsic value | Intrinsic value (which may be zero) | No |
| Share option redeemable at fair value | Fair value | Yes |
| Share option for which underlying share is redeemable at fair value | Intrinsic value of share option or, after exercise, fair value of share | No |
| Share “conditionally” redeemable at fair value: | | |
| 1) Upon contingency not currently probable | Grant-date fair value | No |
| 2) Upon contingency that is probable | Fair value | No |

¹ Example 3.17 is applied when determining the amount for initial classification and does not reflect that in some instances the awards are subsequently remeasured – see Paragraph 3.099

² The amounts classified in temporary equity would apply regardless of whether the grantees were employees or nonemployees.

³ See Question 3.3.20 in KPMG Handbook, Earnings per share.

Q&A 3.33: Presentation in Temporary Equity of Equity-Classified Award Subject to Redemption

Q. ABC Corp., a public company, has issued nonvested shares to its employees through a share-based payment arrangement. Beginning six months after vesting, the employees may, but are not required to, put the shares back to ABC at any time at the then-fair value of the shares. How should the award be classified and presented in ABC's balance sheet?

A. Because the put option is not exercisable until six months after the awards vest, employees are subject to economic risks and rewards of ownership for a reasonable period of time. In addition, the puttable shares are not liability-classified under ASC Topic 480. Consequently, the awards are classified as equity pursuant to the provisions of ASC Topic 718.

However, because the shares can be put to the company, ABC would be required to report the award in temporary equity. The classification of the awards would be the same even if the awards were nonemployee awards instead of employee awards; however, the compensation cost attribution may be different. See Q&A 3.34 for an illustration of how the amount outside permanent equity would be determined each period for the employee awards.

Q&A 3.34: Determining the Amount of Temporary Equity of Equity-Classified Award Subject to Redemption

Q. Assume the same facts as in Q&A 3.33. At the grant date, the shares have a fair value of \$100,000 and cliff vest at the end of four years of service. At the end of Year 1, the shares have a fair value of \$120,000. At the end of Year 2, the shares have a fair value of \$140,000. At the end of Year 3, the shares have a fair value of \$90,000. At the end of Year 4, the shares have a fair value of \$110,000.

What amount would be reported as temporary equity at the end of each year?

A. The amount reported in temporary equity under the guidance in ASC paragraph 718-10-S99-1 would be determined as the redemption amount at each balance sheet date multiplied by the proportion of the requisite service that has been provided to date:

| | | |
|--------|------------------|-----------|
| Year 1 | \$ 120,000 × 1/4 | \$ 30,000 |
| Year 2 | \$ 140,000 × 2/4 | \$ 70,000 |

| | | |
|--------|------------------|------------|
| Year 3 | \$ 90,000 × 3/4 | \$ 67,500 |
| Year 4 | \$ 110,000 × 4/4 | \$ 110,000 |

At each balance sheet date after the awards vest, the amount reported in temporary equity would be equal to the fair value of the shares at the reporting date.

The presentation of the award in temporary equity does not affect the compensation cost. In Years 1 – 4, ABC would recognize compensation cost of \$25,000 (\$100,000 / 4 years), with a corresponding entry to additional paid-in capital.

Q&A 3.35: Profits Interest Units with Contingent Put Feature

Background

Company ABC issues equity-classified profits interest units (PIUs). If employment is terminated due to death or disability, the employees of ABC can put the vested units (which is different from awards vesting *upon* death or disability) to ABC for cash at the intrinsic value of the award at the redemption date (i.e., the awards include a contingent put feature). The contingency, i.e., death or disability, are events that are considered outside of the control of ABC and the employee and are also events not deemed to be probable of occurring prior to their occurrence.

ABC has determined that the PIUs are more akin to stock options granted “at the money” that only participate in increases in the fair value of ABC from the grant date. See Paragraph 4.134 for considerations around PIUs and determining whether they are more akin to stock options or shares.

Q. Should any amount related to the PIUs, akin to stock options granted at the money be presented outside of permanent equity because of the contingent put feature?

A. Share option awards initially granted at the money would have no initial redemption amount. Since the grant-date redemption value is zero (the awards are granted at the money; therefore the exercise price is equal to the fair value), there is no amount to be presented outside of permanent equity. If the contingent event is not probable of occurring, subsequent remeasurement of the initial amount classified outside of permanent equity is not made until the contingent event becomes probable at a future date, which is not achieved until the event occurs. If the event occurs, the compensation cost recorded at that point will be based on the fair value of the awards at that date. Note that if the awards are modified before the event occurs, and there is intrinsic value in the awards at the time of the modification (therefore, there is a probable-to-probable modification), the portion related to the intrinsic value on remeasurement of the award would be recognized outside of permanent equity at the time of the modification.

Example 3.18: Share-Based Payment Award That Is Expected to Become Redeemable

On January 1, 20X6, ABC Corp., an SEC registrant, grants 10,000 share options to employees. The share options have an exercise price of \$20 per share (which equals the stock's market price on the grant date), a grant-date fair value of \$10 per share option, and vest after four years of service. Once the share options are exercised, the employee can put the shares back to ABC after six months at the then-current market price of the shares. The share options are equity-classified under ASC Topic 718. All the share options vest on December 31, 20X9 and all share options are exercised on December 1, 20Y0. The market price of the underlying shares is:

| | |
|-------------------|------|
| December 31, 20X6 | \$32 |
| December 31, 20X7 | \$24 |
| December 31, 20X8 | \$16 |
| December 31, 20X9 | \$40 |
| December 31, 20Y0 | \$70 |

The repurchase feature will not result in liability classification of the stock awards under Topic 718 since the employee will bear the risks and rewards of share ownership for a period of more than six months after the stock awards have vested. However, as an SEC registrant, ABC Corp. must apply ASC paragraphs 480-10-S99-1 and 480-10-S99-3A. As the redemption feature is available six months after the stock awards vest, changes in the value of the redemption feature are recognized in temporary equity. The amount reported as compensation cost, assuming forfeitures are not expected to occur, as well as the amount classified outside of permanent equity at each balance sheet date would be:

| Date | Compensation Cost for the Year | Cumulative Amount Recorded in Permanent Equity ⁶ | Redemption Amount Recorded Outside of Permanent Equity |
|----------|--------------------------------|---|--|
| 12/31/X6 | \$ 25,000 | \$ (5,000) | \$ 30,000 ¹ |
| 12/31/X7 | 25,000 | 30,000 | 20,000 ² |
| 12/31/X8 | 25,000 | 75,000 | 0 ³ |
| 12/31/X9 | 25,000 | (100,000) | 200,000 ⁴ |
| 12/31/Y0 | 0 | (100,000) ⁷ | 700,000 ⁵ |

¹ $(\$32 - \$20) \times 1 \text{ year} / 4 \text{ years} \times 10,000 \text{ share options}$

² $(\$24 - \$20) \times 2 \text{ years} / 4 \text{ years} \times 10,000 \text{ share options}$

³ $(\$16 - \$20) \times 3 \text{ years} / 4 \text{ years} \times 10,000 \text{ share options}$; however, redemption amount cannot be less than \$0

⁴ $(\$40 - \$20) \times 4 \text{ years} / 4 \text{ years} \times 10,000 \text{ share options}$

⁵ $\$70 \times 10,000 \text{ shares}$, because the share options have been exercised by the employees

⁶ Amount is recorded to permanent equity based on the equity-classified Topic 718 compensation expense; therefore, it is $(10,000 \text{ options} \times \$10) / 4 = \$25,000$ recorded to permanent equity each year adjusted for the amount reclassified to temporary equity.

⁷ No additional compensation cost is recognized in 12/31/Y0.

Journal entries for 12/31/X6 and 12/31/X7 are as follows.

12/31/X6

| | Debit | Credit |
|-------------------|--------|--------|
| Compensation cost | 25,000 | |
| APIC | | 25,000 |

To recognize compensation cost based on grant-date fair value.

| | | |
|------------------|--------|--------|
| APIC | 30,000 | |
| Temporary equity | | 30,000 |

To recognize the redemption feature value in temporary equity.

12/31/X7

| | | |
|-------------------|--------|--------|
| Compensation cost | 25,000 | |
| APIC | | 25,000 |

To recognize compensation cost based on grant-date fair value.

| | | |
|------------------|--------|--------|
| Temporary equity | 10,000 | |
| APIC | | 10,000 |

To reduce temporary equity to recognize the change in the 12/31/X7 redemption feature value (\$30,000 - \$20,000).

Amounts classified outside of permanent equity do not affect earnings available to common shareholders in the EPS calculations because the shares involved are common shares and the redemption amount is not greater than fair value.

Impact of ASC paragraph 480-10-S99-3A on Contingently Cash Settleable Awards

3.099 For equity-classified share-based payment awards with repurchase features that are triggered by contingent events beyond the company's control that are not probable of occurrence, the redemption amount is measured on the grant date of the award. This redemption amount will not be remeasured as long as the event does not become probable of occurrence. As noted above, if the contingent event were to become probable of occurrence, the award would become liability-classified and additional compensation cost may need to be recorded under ASC Topic 718. Compensation cost for an award reclassified from equity to liability cannot be less than the grant-date fair value of the equity award. Therefore, if the fair value of the liability-classified award is less than the grant-date fair value of the equity award, the amount of compensation cost recognized is

not adjusted. However, any excess of the fair value of the liability-classified award over the equity classified grant date fair value of the award would be recognized as compensation cost. Because the award would become liability-classified, ASC paragraph 480-10-S99-3A would no longer apply.

3.100 Contingent cash settlement features that are within the control of the company would not cause an equity-classified award to be classified as temporary equity. There are two key differences between ASC Topic 718 and ASC paragraph 480-10-S99-3A that are considered in evaluating contingent redemption features. First, ASC Topic 718 focuses on events that are outside the *grantee's* control in determining whether the instrument is equity-classified. ASC paragraph 480-10-S99-3A focuses on events that are outside the control of the *company* in determining whether some amount may need to be classified outside of permanent equity. As a result, in only limited circumstances, certain instruments with contingent redemption features that are equity-classified based on the guidance of ASC Topic 718 will *not* be a redeemable security under ASC paragraph 480-10-S99-3A. Determining whether a share-based payment award is redeemable at the option of the grantee or on the occurrence of an event that is outside the control of the company can be complex. All of the individual facts and circumstances are evaluated in determining how the award should be classified. For example, a cash repurchase feature based on the occurrence of an IPO may be an event that is outside the grantee's control but is within the control of the company. Conversely, other liquidity events, such as a sale of a significant investor's interest in the company may be outside the control of both the grantee and the company.

3.101 ASC Topic 718 uses a grant-date fair value measurement attribute for equity-classified awards to determine the amount to be recorded as compensation cost, whereas ASC paragraph 480-10-S99-3A uses a grant-date redemption value measurement to determine the amount to be classified outside of permanent equity. As a result, the amount classified outside of permanent equity may not be the same as the amount recorded in paid-in capital for the instrument. The amount classified outside of permanent equity may be equal to, less than, or more than the amount recorded in equity from the recognition of compensation cost. For equity-classified share-based payment instruments in which the contingent cash settlement feature is beyond the control of the company, the amount that initially should be classified outside of permanent equity is based on the grant-date redemption value of the award and the proportion of goods and services provided to date. For most awards, the written terms of the plan provide for the redemption at the intrinsic value of the award at the redemption date. In these situations, such share-option awards initially granted *at-the-money* would have no initial redemption amount. If the contingent event is not probable of occurring, subsequent adjustment to the initial amount classified outside of permanent equity is *not* made. See Example 3.17.

3.102 Amounts classified outside of permanent equity for equity-classified awards that have contingent cash-settlement features do not affect earnings available to common shareholders in EPS calculations as long as the shares are common shares and the redemption amount is not greater than fair value.

3.103 Consistent with related guidance in ASC Topic 480 and ASC paragraph 480-10-S99-3A, a share-based payment award with a contingent cash-settlement feature that requires redemption of the share-based payment award only in the event that *all* equity holders' interests are redeemed, would not result in the share-based payment award being classified as a liability on the event becoming probable of occurring nor in an amount being classified outside of permanent equity. An event that involves the redemption of *all* equity holders would include the sale of a company in an all-cash transaction or a liquidation of the company.

Example 3.19: Awards Containing a Contingent Repurchase Feature – Part I

On January 1, 20X4, ABC Corp., an SEC registrant, grants 10,000 share options to employees. The share options have an exercise price of \$10 per share (which equals the stock's market price on the grant date), a grant-date fair value of \$5, and cliff vest after four years of service. The award contains a contingent cash repurchase feature at the intrinsic value of the share option upon a change in control. However, throughout the service period, it is not probable that a change in control will occur. ABC initially applied ASC paragraph 718-10-35-15 to account for the award and the award is considered an equity-classified award. However, ABC also considers the guidance in ASC paragraph 480-10-S99-3A. All the share options vest on December 31, 20X7 (i.e., there are no forfeitures) and the redemption feature never became probable. The market price of the underlying shares is:

| | |
|-------------------|------|
| December 31, 20X4 | \$12 |
| December 31, 20X5 | \$20 |
| December 31, 20X6 | \$16 |
| December 31, 20X7 | \$30 |

The amount reported as compensation cost as well as the amount classified outside of permanent equity at each balance sheet date would be:

| Date | Compensation Cost for the Year | Cumulative Amount Recorded in Permanent Equity | Redemption Amount Recorded Outside of Permanent Equity ³ |
|----------|--------------------------------|--|---|
| 12/31/X4 | \$ 12,500 ¹ | \$ 12,500 | \$ 0 ² |
| 12/31/X5 | 12,500 | 25,000 | 0 |
| 12/31/X6 | 12,500 | 37,500 | 0 |
| 12/31/X7 | 12,500 | 50,000 | 0 |

¹ Compensation cost was recognized ($\$5$ grant-date fair value \times 1 year / 4 years \times 10,000 share options)

² Grant-date intrinsic value is zero, thus no amount is classified outside of permanent equity in applying ASC paragraph 480-10-S99-3A

³ The amount recorded to permanent equity is not remeasured unless the contingent event becomes probable. If there is intrinsic value on the grant date, there would be an amount recorded to temporary equity (see Example 3.21).

Note that the classification answer would be the same regardless of whether the award is an employee or nonemployee award.

Example 3.20: Not used.

Example 3.21: Awards Containing a Contingent Repurchase Feature – Part II

Assume the same facts as in Example 3.19, except the market price of the stock on the date of grant was \$12, thus the award contained a grant-date intrinsic value of \$2 (\$12 market price - \$10 exercise price). The amount reported as compensation cost as well as the amount classified outside of permanent equity at each balance sheet date would be:

| Date | Compensation Cost for the Year | Cumulative Amount Recorded in Permanent Equity | Redemption Amount Recorded Outside of Permanent Equity ³ |
|----------|--------------------------------|--|---|
| 12/31/X4 | \$ 12,500 ¹ | \$ 7,500 | \$ 5,000 ² |
| 12/31/X5 | 12,500 | 15,000 | 10,000 |
| 12/31/X6 | 12,500 | 22,500 | 15,000 |
| 12/31/X7 | 12,500 | 30,000 | 20,000 |

¹ Compensation cost was recognized based on grant-date fair value (\$5 grant-date fair value × 1 year / 4 years × 10,000 share options)

² The amount classified outside of permanent equity is based on the grant-date intrinsic value and the proportionate amount of the requisite service that has been provided as of the balance sheet date (e.g., as of 12/31/X4 this would be \$2 grant-date intrinsic value × 1 year / 4 years × 10,000 share options)

³ The amount recorded to permanent equity is not remeasured unless the contingent event becomes probable.

Journal entries for 12/31/X4 through 12/31/X7 are as follows.

| | Debit | Credit |
|-------------------|--------|--------|
| Compensation cost | 12,500 | |
| APIC | | 12,500 |

To recognize compensation cost based on grant date fair value.

| | | |
|------------------|-------|-------|
| APIC | 5,000 | |
| Temporary equity | | 5,000 |

To reclassify the grant-date intrinsic value to temporary equity, for the redemption feature.

Assume that all the awards are exercised on December 31, 20X8. Following the exercise the holder owns a share of common stock for which there is no contingent or mandatory cash settlement feature. On exercise, ABC would transfer the amount classified as temporary equity back to permanent equity.

Example 3.22: Awards Containing a Contingent Repurchase Feature – Part III

Assume the same facts as in Example 3.19, except the redemption value provided to the grantee on a change in control is based on the fair value of the award using an option pricing model (\$5 at the grant-date). The amount reported as compensation cost as well as the amount classified outside of permanent equity at each balance sheet date would be:

| Date | Compensation Cost for the Year | Cumulative Amount Recorded in Permanent Equity ³ | Redemption Amount Recorded Outside of Permanent Equity |
|----------|--------------------------------|---|--|
| 12/31/X4 | \$ 12,500 ¹ | \$ 0 | \$ 12,500 ² |
| 12/31/X5 | 12,500 | 0 | 25,000 |
| 12/31/X6 | 12,500 | 0 | 37,500 |
| 12/31/X7 | 12,500 | 0 | 50,000 |

¹ Compensation cost is recognized based on grant-date fair value for the remaining portion of the employee's requisite service period ($\$5 \text{ grant-date fair value} \times 1 \text{ year} / 4 \text{ years} \times 10,000 \text{ share options}$)

² Because the grant date redemption value is not based on the intrinsic value of the award, but rather is based on the fair value of the award, the entire grant-date fair value of the award is recognized outside of permanent equity, adjusted to take into consideration the proportionate amount of the requisite service that has been provided as of the balance sheet date (e.g., as of 12/31/X4 this would be $\$5 \text{ grant-date fair value} \times 1 \text{ year} / 4 \text{ years} \times 10,000 \text{ share options}$).

³ There is \$0 in cumulative amount recorded for permanent equity, as the redemption value outside of permanent equity is the total fair value of the option. This is because the redemption value is not based on intrinsic value, but rather is based on the fair value of the award. This is similar to when there is a nonvested share with a contingent cash settlement feature (instead of an option) with no initial cash investment; the amount to be classified outside of permanent equity will be based on the grant-date fair value of the shares (see Example 3.23). However, if the redemption value was based on intrinsic value (see Example 3.21), the amount outside of permanent equity would be limited to the intrinsic value, with the

difference between the grant date fair value and the intrinsic value of the award remaining in permanent equity.

Example 3.22.1: Awards Containing a Contingent Repurchase Feature – Part IV

On January 1, 20X8, ABC, an SEC registrant, grants 10,000 share options to employees. The share options have an exercise price of \$10 per share when ABC's share price is \$15. Therefore, the options have an intrinsic value of \$5 per share on the grant date. The grant-date fair value is \$7, and the share options cliff vest after two years of service. The award contains a contingent cash put feature at the intrinsic value of the share options, which gives the employee the right to require ABC to net cash settle the options on a change of control.

A change in control is not probable on the issuance date. Therefore, ABC initially classifies the share options as equity. Because it is an SEC registrant, ABC records a portion of this equity in temporary equity following the guidance in ASC paragraph 480-10-S99-3A.

During 20X8 and 20X9, ABC recognizes the following compensation cost related to the share options:

| Date | Compensation Cost for the Year | Cumulative Amount Recorded in Permanent Equity | Redemption Amount Recorded Outside of Permanent Equity |
|----------|--------------------------------|--|--|
| 12/31/X8 | \$ 35,000 ¹ | \$ 10,000 | \$ 25,000 ² |
| 12/31/X9 | 35,000 | 20,000 ³ | 50,000 ⁴ |

¹ Compensation cost is recognized based on grant-date fair value of the employee's requisite service period (\$7 grant-date fair value × 1 year / 2 years × 10,000 share options)

² The grant-date intrinsic value recognized outside of permanent equity is based on the grant-date intrinsic value and the proportionate amount of the employee's requisite service that has been provided as of the balance sheet date (e.g., as of 12/31/X8 this would be \$5 grant-date intrinsic value × 1 year / 2 years × 10,000 share options).

³ The cumulative amount in permanent equity is \$35,000 compensation cost for 12/31/X9 + \$10,000 (previous balance) – \$25,000 redemption amount recorded outside of permanent equity in 12/31/X9.

⁴ The grant-date intrinsic value recognized outside of permanent equity is based on the grant-date intrinsic value and the proportionate amount of the employee's requisite service that has been provided as of the balance sheet date [(e.g., as of 12/31/X9 this would be \$5 grant-date intrinsic value × 2 years / 2 years × 10,000 share options).

Change in control becomes probable

On March 1, 20Y0, a change in control becomes probable and the fair value of the options is \$13. As a result, ABC reclassifies the options as a share-based liability. The amount of this liability is based on the portion of the options related to prior service, multiplied by the options' \$13 fair value on the date a change in control becomes probable (March 1,

20Y0). The difference between this initial amount of the share-based liability and the balance in temporary equity as of February 28, 20Y0 is accounted for as follows:

- Any excess of the temporary equity balance over the share-based liability is recorded to APIC
- Any excess of the share-based liability over the temporary equity balance is recognized as compensation cost either immediately (for vested options) or over the remaining service (vesting) period (for unvested options, see Paragraph 3.104)
- Once the options are classified as a liability, they are remeasured at fair value in each reporting period until settlement.

On March 1, 20Y0, ABC records the following entries to reclassify the options from temporary equity to a liability:

| | Debit | Credit |
|------------------|--------|--------|
| Temporary equity | 50,000 | |
| APIC | | 50,000 |

To reverse the amount previously recognized in temporary equity once the change in control becomes probable.

| | | |
|-----------------------|--------|----------------------|
| APIC | 70,000 | |
| Compensation cost | 60,000 | |
| Share-based liability | | 130,000 ⁵ |

⁵ Share-based liability calculated based on the fair value of the options on the date a change in control becomes probable ($\$13 \times 10,000$ share options).

To recognize (1) a share-based liability on the basis of the fair-value-based measure of the options on the date the change in control becomes probable and (2) compensation cost for the excess of the share-based liability over the amount of compensation cost previously recognized ($\$130,000 - \$70,000 = \$60,000$ of additional compensation cost).

Nonvested Shares with a Contingent Cash Settlement Feature

3.104 Nonvested shares generally have grant-date redemption value equal to the fair value of the shares at issuance, because the grantees usually are not required to pay consideration (beyond providing goods or services) to receive the shares. As a result, for nonvested shares with a contingent cash redemption feature that is outside the control of the company, but not probable of occurrence, and redeemable at the fair value of the shares and for which the grantee made no initial cash investment, the amount to be classified outside of permanent equity will be based on the grant-date fair value of the shares. During the service or vesting period, the amount reflected outside of permanent equity will be based on the grant-date redemption value, and the proportion of the service

provided to date, but the redemption amount would not be remeasured because the contingent event is not currently probable.

Example 3.23: Nonvested Shares Containing a Contingent Repurchase Feature

On January 1, 20X6, ABC Corp. grants 10,000 nonvested shares to employees. The nonvested shares have a fair value of \$10 per share (the market price of the stock on the grant date) and cliff vest after three years of service. The award contains a contingent cash repurchase feature at the stock's then-current market price on a change in control. However, throughout the service period, it is not probable that a change in control will occur. All of the nonvested shares vest on December 31, 20X8 (i.e., there are no forfeitures). The amount reported outside of permanent equity at each balance sheet date would be:

| Date | Compensation Cost for the Year | Cumulative Amount Recorded in Permanent Equity | Redemption Amount Recognized Outside of Permanent Equity |
|----------|--------------------------------|--|--|
| 12/31/X6 | \$ 33,333 | \$ 0 | \$ 33,333 |
| 12/31/X7 | 33,333 | 0 | 66,666 |
| 12/31/X8 | 33,334 | 0 | 100,000 |

There is \$0 in recognized in permanent equity, as the redemption value outside of permanent equity is the total fair value of the nonvested shares; there is no initial investment by the grantee to exercise the redemption feature. Refer to Example 4.20 for an extension of this example that considers the effect of forfeitures on the redemption amount classified outside of permanent equity.

Interaction of ASC Topic 718, SEC Literature, and ASC Subtopic 810-10

3.105 A subsidiary of a public company may issue to its employees a share-based payment award that is required to be presented outside of permanent equity in accordance with ASC paragraphs 210-10-S99-1 or 480-10-S99-3A. In addition to being classified outside of permanent equity, this award may have an impact on the presentation of noncontrolling interests under ASC Subtopic 810-10, *Consolidation – Overall*.

3.106 During the employee requisite service period and nonemployee vesting period of the award, compensation cost is recognized under ASC Topic 718. Q&A 1.13 describes a policy election related to whether the compensation cost is recognized by an increase to noncontrolling interest or the parent's additional paid-in capital. Whichever policy is selected, no earnings or losses are attributed to the noncontrolling interest while the share

options remain outstanding (this assumes the holder of the award does not participate in dividends. If so, there may be an allocation of earnings to the awards as part of applying the two-class method of earnings per share. Refer to KPMG Handbook, Earnings Per Share, Chapter 5, for further discussion). The noncontrolling interest associated with the unvested awards would be classified outside of permanent equity pursuant to the classification guidance in ASC paragraphs 718-10-S99-1 and 480-10-S99-3A. If there are other noncontrolling interests in the same subsidiary that are not contingently redeemable, this would result in the noncontrolling interests appearing on two different line items on the parent's balance sheet.

3.107 If classified outside of permanent equity based on the guidance in ASC paragraphs 718-10-S99-1 and 480-10-S99-3A, the noncontrolling interest associated with the unvested award should be measured at the greater of (a) the cumulative compensation cost recognized under ASC Topic 718 or (b) the product of (1) the redemption amount of the award (i.e., based on the current share price) multiplied by (2) the percentage of the requisite service that has been completed. As neither ASC paragraph 480-10-S99-3A nor ASC paragraph 718-10-S99-1 specifies whether the adjustment should be recorded to retained earnings or additional paid-in capital, an accounting policy should be made as to where those adjustments are recorded.

3.108 On vesting, the adjustments recorded during the vesting period under ASC paragraph 480-10-S99-3A should be reversed within permanent equity. The noncontrolling interest should initially be adjusted to the amount representing the decrease in the parent's interest in the book value of the subsidiary, with an offsetting adjustment to additional paid-in capital. This adjustment may require either an increase or decrease to the carrying amount of the noncontrolling interests previously recorded from the recognized compensation cost during the vesting period as that was based on the award's grant-date fair value.

3.109 In periods after vesting, the redeemable noncontrolling interest should be measured at the greater of the amount that reflects the attribution of comprehensive income or loss for each period or the amount determined under ASC paragraph 480-10-S99-3A.

3.110 If the award expires unexercised, and the entity elected to initially recognize noncontrolling interest, then the amount recognized in noncontrolling interest should be reclassified from the noncontrolling interest to the controlling interest based on ASC paragraph 810-10-45-17A. No adjustment is required if the entity elected to initially recognize the amount in additional paid-in capital.

Example 3.24: Interaction of ASC Topic 718, SEC Guidance, and ASC Subtopic 810-10

On January 1, 20X0, a subsidiary (Subsidiary) of a public company (Parent) grants 1,000 equity-classified restricted stock units (RSUs) that cliff vest in three years. The RSUs do not participate in dividends and the grant-date fair value is \$100,000. The shares issuable under the award become redeemable at fair value six months and one day after vesting.

The fair value, vesting percentage, and ASC paragraph 480-10-S99-3A measurement of 1,000 shares are as follows at the end of each reporting period:

| Reporting Period | Fair Value | Vesting Percentage | ASC paragraph 480-10-S99-3A Measurement |
|-------------------------|-------------------|---------------------------|--|
| 20X0 | \$120,000 | 33% | \$40,000 |
| 20X1 | 150,000 | 67% | 100,000 |
| 20X2 | 140,000 | 100% | 140,000 |
| 20X3 | 135,000 | 100% | 135,000 |

Other assumptions used in the example:

- Subsidiary's book value in Parent's consolidated financial statements on vesting = \$1 million.
- Subsidiary's comprehensive income in 20X3 is \$300,000.
- Subsidiary has 100,000 outstanding shares immediately prior to vesting; all held by Parent.
- Parent's policy is to record adjustments to the carrying amount of redeemable noncontrolling interests under ASC paragraph 480-10-S99-3A to additional paid-in capital when the adjustment does not affect the numerator of earnings per share calculations.
- The estimated and actual forfeitures were zero for purposes of recognizing compensation costs.
- All RSUs vest in 20X2

On December 31, 20X0, Parent would record the following in its consolidated financial statements:

| | Debit | Credit |
|--------------------------|--------------|---------------|
| Compensation cost | 33,333 | |
| Noncontrolling interests | | 33,333 |

To record compensation cost based on grant-date fair value.

| | | |
|-------------------------------------|--------|--------|
| Noncontrolling interests | 33,333 | |
| Additional paid-in capital | 6,667 | |
| Redeemable noncontrolling interests | | 40,000 |

To apply the ASC paragraph 480-10-S99-3A measurement guidance to the unvested awards.

3. Classification of Awards as Either Liabilities or Equity

On December 31, 20X1, Parent would record the following in its consolidated financial statements:

| | Debit | Credit |
|--------------------------|--------|--------|
| Compensation cost | 33,333 | |
| Noncontrolling interests | | 33,333 |

To record compensation cost based on grant-date fair value.

| | | |
|-------------------------------------|--------|--------|
| Noncontrolling interests | 33,333 | |
| Additional paid-in capital | 26,667 | |
| Redeemable noncontrolling interests | | 60,000 |

To apply the ASC paragraph 480-10-S99-3A measurement guidance to the unvested awards.

On December 31, 20X2 (vesting date), Parent would record the following in its consolidated financial statements:

| | | |
|--------------------------|--------|--------|
| Compensation cost | 33,334 | |
| Noncontrolling interests | | 33,334 |

To record compensation cost based on grant-date fair value.

| | | |
|-------------------------------------|--------|--------|
| Noncontrolling interests | 33,334 | |
| Additional paid-in capital | 6,666 | |
| Redeemable noncontrolling interests | | 40,000 |

To reverse the cumulative adjustments as required by the ASC paragraph 480-10-S99-3A measurement guidance for unvested awards, adjust for the reduction in the ownership interest of Parent as required under ASC Subtopic 810-10, and apply the ASC paragraph 480-10-S99-3A measurement guidance to the redeemable noncontrolling interest.

On December 31, 20X3, Parent would record the following in its consolidated financial statements:

| | | |
|--|---------|---------|
| Comprehensive income | 300,000 | |
| Redeemable noncontrolling interests ⁽¹⁾ | | 2,970 |
| Retained earnings | | 297,030 |

To record the allocation of the comprehensive income.

| | | |
|--|-------|-------|
| Redeemable noncontrolling interests ⁽²⁾ | 7,970 | |
| Additional paid-in capital | | 7,970 |

To record an adjustment to apply the ASC paragraph 480-10-S99-3A measurement guidance to the redeemable noncontrolling interest.

⁽¹⁾ $\$300,000 \times 0.99\%$ (ownership interest) = \$2,970

⁽²⁾ $(\$135,000 - \{\$9,900 \text{ recognized in } 20X2 + \$2,970 \text{ recognized in } 20X3\}) - \$130,100$ excess recognized in 20X2

NOTE: The amount recorded in 20X3 (after allocating comprehensive income for the period between the controlling interest and the redeemable noncontrolling interest) to measure the redeemable noncontrolling interest at \$135,000, should be the excess of the amount measured under ASC paragraph 480-10-S99-3A and the amount measured under ASC Topic 810 adjusted for the excess recorded in 20X2.

¹ Promissory estoppel is a legal principle that states that a promise made without consideration may nonetheless be enforced to prevent an injustice if the promisor should have reasonably expected the promisee to rely on the promise and the promisee did actually rely on the promise to his or her detriment.

Section 4 - Recognition of Compensation Costs

Detailed Contents

Overview

Equity-Classified Awards

Service Inception Date

Evaluating Whether Service Inception Date Precedes Grant Date for Employee Awards

Application of ASC paragraphs 718-10-55-108 and 55-109 to Liability- and Equity-Classified Awards

Awards Settled in Cash and Equity at the Grantee's Election

Grant Date

Q&A 4.1: Determining the Grant Date – Approval Process Part I

Q&A 4.2: Determining the Grant Date – Approval Process Part II

Q&A 4.2a: Determining the Grant Date – Approval Process Part III

Q&A 4.2b: Determining the Grant Date – Approval Process Part IV

Example 4.0: Grant Date for Employee Awards with Board Approval

Q&A 4.3: Determining the Grant Date – Performance Condition

Q&A 4.4: Determining the Service Inception Date and Grant Date for Employee Awards

Q&A 4.4a: Stock Option Repricing and Whether the Service Inception Date precedes the Grant Date for Employee Awards

Example 4.1: Service Inception Date and Grant Date for Employee Awards – Part I

Example 4.1a: Service Inception Date and Grant Date for Employee Awards – Part II

Q&A 4.5: Accounting for Shares Authorized In A Share-Based Payment Plan When All Shares Must Be Paid Out

Example 4.2: Option Offer before the Service Inception and Grant Date

Example 4.3: Award Does Not Include a Substantive Future Service Condition at the Grant Date

Example 4.4: Award Contains a Performance Condition That if Not Satisfied before the Grant Date Results in Forfeiture of the Award

Example 4.5: Service Inception Date Precedes the Grant Date – Award with Multiple Service Periods

Example 4.6: Grant Date Precedes the Service Inception Date – Performance Award with Multiple Service Periods

- Example 4.7: Service Inception Date Precedes the Grant Date – Performance Award Based on Future Net Income
- Example 4.8: Grant Date Is Service Inception Date – Performance Award with Multiple Service Periods – Part I
- Example 4.9: Grant Date Is Service Inception Date – Performance Award with Multiple Service Periods – Part II
- Effect of Compensation Committee Discretion Clauses on Determining Grant Date
- Q&A 4.5a: Effect of Discretionary Clause on Clawback Feature
- Discretionary Clawback Provisions (Including Effect of Dodd-Frank Wall Street Reform and Consumer Protection Act)
- Requisite Service or Nonemployee Vesting Period
- Service Condition
- Q&A 4.6: Grant for Past Service with Future Vesting Period
- Example 4.10: Award Granted to a Retirement-Eligible Employee Does Not Include a Substantive Future Service Condition at the Grant Date – Part I
- Example 4.10a: Award Granted to a Retirement-Eligible Employee Does Not Include a Substantive Future Service Condition at the Grant Date – Part II
- Q&A 4.7: Grant When Continued Employment Is Not Required but Exercisability Is Deferred
- Q&A 4.8: Grant When Continued Employment Is Required
- Q&A 4.9: Grant of a Performance-Based Award to Retirement Eligible Employees Service Condition in a Grant of Deep Out-of-the-Money, Fully Vested Share Options
- Q&A 4.10: Grant of Fully Vested, Deep Out-of-the-Money Share Options Service Condition with Employee Grants Containing a Noncompete Provision
- Nonsubstantive Service Period
- Example 4.11: Effect of Nonsubstantive Service on an Employee Requisite Service Period
- Example 4.11a: Share Option Awards Granted to Retirement-Eligible Employees with a Service and Performance Condition that Can Be Achieved after Retirement
- Implicit Service Condition from Escrowed Share Arrangements
- Q&A 4.10a: Buyback Provision Amendment Creates Implicit Service Condition
- Performance Condition
- Q&A 4.11: Vesting Based on EPS Growth – Part I
- Q&A 4.12: Vesting Based on EPS Growth – Part II
- Q&A 4.13: Vesting Based on EPS Growth – Part III
- Q&A 4.13b: Vesting is Conditioned Upon Occurrence of an Exit Event at a Significant Stakeholder Level

Q&A 4.14: Interaction of Nonsubstantive Service Period with a Performance Condition

Market Condition

Q&A 4.15: Vesting Based on the Share Price Outperforming the S&P 500 Index
Summary of Conditions

Example 4.12: Conditions and Related Employee Service Period of an Award
Multiple Conditions

Attribution Period for Employee Awards with a Service Condition

Cliff-Vesting Awards

Example 4.13: Recognition of Compensation Cost for a Cliff-Vesting Award

Graded-Vesting Employee Awards

Example 4.14: Attribution of Compensation Cost for a Graded-Vesting Award –
Straight-Line Basis

Q&A 4.15aa: Attribution of Compensation Cost for an Award with a Service
Condition and Accelerated Vesting on an IPO or Change of Control

Example 4.15: Applying a *Broad-Broad* Policy Election in Accordance with ASC
Subparagraph 718-10-55-108(c)(2) to an Award with Graded Vesting

Example 4.16: Attributing Compensation Cost for a Graded-Vesting Award –
Tranche by Tranche

Attribution for Nonemployee Awards

Example 4.16a: Attribution of Compensation Cost for Stock Options Provided to a
Supplier

Example 4.16b: Attribution of Compensation Cost for Stock Options Provided to a
Service Provider

Estimating Forfeitures – for both Employee and Nonemployee Awards

Q&A 4.15a: Separate Entity-Wide Policy Election on Estimating Forfeitures for
Employee and Nonemployee Awards

Example 4.16c: Cliff-Vesting Awards with Accounting for Forfeitures When They
Occur

Example 4.16d: Award with both a Service and Performance Condition when
Large-Scale Forfeitures Are Known

Example 4.17: Graded-Vesting Employee Award with Estimated Forfeitures

Example 4.18: Attribution of Compensation Cost for a Graded-Vesting Employee
Award Adjusted for Actual Forfeitures

Example 4.19: Cliff-Vesting Awards with Estimated Forfeitures

Example 4.20: Applying Estimate of Forfeitures to Nonvested Share Awards
Containing a Contingent Repurchase Feature

Q&A 4.15b: Effect of Chapter 11 Reorganization on Assumed Forfeiture Rates

Example 4.21: Change in Estimated Number of Forfeitures

Example 4.22: Change in Estimated Number of Forfeitures—Revision in More Than One Period

Example 4.22a: Record Forfeitures as They Occur

Attribution Period for Employee Awards with Performance Conditions

Example 4.23: Award Containing a Performance Condition with an Explicit Service Period

Example 4.23a: Award Containing a Performance Condition with an Explicit Service Period and a Change in Estimated Forfeitures

Example 4.23b: Award Containing a Performance Condition with an Implicit Service Period Which Becomes an Explicit Service Period upon IPO

Example 4.24: Performance Award That Contains Annual Performance Targets That Include Carryback and Carryforward Provisions

Q&A 4.16: Employee Requisite Service Period for a Performance-Based Award

Example 4.25: Performance Award with Multiple Implicit Service Periods – Part I

Example 4.26: Performance Award with Multiple Implicit Service Periods – Part II

Example 4.27: Reflecting Changes in Estimates

Q&A 4.17: Vesting Dependent on a Performance Condition - Scenario 1

Q&A 4.18: Vesting Dependent on a Performance Condition - Scenario 2

Example 4.28: Award Includes a Performance Condition Based on Occurrence of an IPO After Employment

Example 4.29: Award Includes a Performance Condition Based on EBIDTA Targets

Example 4.30: Changes in the Likelihood of Achieving a Performance Condition

Attribution for Nonemployee Awards with Performance Conditions

Attribution Period for Employee Awards with Market Conditions

Example 4.31: Award Containing a Market Condition

Example 4.31a: Recognition of Awards with Different Market Conditions at Different Dates

Example 4.31b: Award Containing a Market Condition with an Explicit Service Period and a Change in Estimated Forfeitures

Attribution for Nonemployee Awards with Market Conditions

Attribution Period for Employee Awards Requiring Satisfaction of Service *or* Performance Conditions

Q&A 4.19: Employee's Requisite Service Period for an Award with a Performance-Based Acceleration Clause and a Service Condition

Example 4.32: Change in Employee's Requisite Service Period Based on Accelerated Vesting—Grant of Nonvested Shares

Example 4.33: Change in Employee's Requisite Service Period Based on Accelerated Vesting—Grant of Nonvested Shares

Q&A 4.20: Vesting Based on an IPO or Change of Control

Attribution Period for Employee Awards Requiring Satisfaction of Service *and* Performance Conditions

Q&A 4.21: Requisite Service Period for an Award with Both a Service and Performance Condition (Implicit Service Period Longer)

Q&A 4.22: Requisite Service Period for an Award with Both a Service and Performance Condition (Explicit Service Period Longer)

Q&A 4.23: Requisite Service Period for an Award with Both a Service and Performance Condition (Performance Condition Not Probable of Achievement)

Attribution Period for Awards Requiring Satisfaction of Service or Performance Conditions and Market Conditions

Example 4.34: Exercisability or Vesting Dependent on Achievement of *Either* a Market or Service Condition

Example 4.35: Exercisability or Vesting Dependent on Both a Market Condition and a Service Condition—Derived Service Period Is Shorter Than Explicit Service Period

Example 4.35a: Vesting or Exercisability Dependent on a Service Condition AND either a Market Condition OR a Performance Condition

Example 4.36: Vesting or Exercisability Dependent on Both a Market Condition and a Service Condition (Derived Service Period Is Longer Than Explicit Service Period)

Example 4.37: Vesting or Exercisability Dependent on Both a Market Condition and a Performance Condition for a Private Equity Investment

Attribution Period for Awards Requiring Satisfaction of a Combination of a Performance and a Market Condition

Example 4.38: Vesting and Exercisability Depending on a Combination of a Performance Condition and a Market Condition (One Award)

Example 4.38a: Vesting Depending on a Combination of a Performance Condition and a Market Condition (Two Awards)

Example 4.38b: Vesting and Exercisability of Awards with a Market Condition and an Implied Performance Condition

Service, Performance, and Market Conditions That Affect Factors Other Than Vesting or Exercisability

Example 4.39: Performance Condition That Affects the Number of Awards

Example 4.40: Performance Condition That Affects Grant-Date Fair Value

Dividends on Awards

Liability-Classified Awards

Example 4.41: Liability-Classified Award with No Forfeitures

Example 4.42: Liability-Classified Award with Forfeitures

Q&A 4.24: Bonus Plan

Q&A 4.25: Bonus Plan with a Subsequent Service Period

Example 4.43: Bonus Plan with a Look-Back Feature

Classification of Compensation Cost

Q&A 4.25.1: Capitalization of Compensation Cost

Employer Loan Features

Nonrecourse Loan to Employees

Q&A 4.29: Consideration of Interest on a Nonrecourse Note in the Measurement of Grant-Date Fair Value of a Share-Based Payment Award

Q&A 4.29a: Subsequent Issuance of Nonrecourse Loan for Cash

Recourse Loan to Employees

Combination Recourse and Nonrecourse Loan to Employees

Awards Granted to Customers

OVERVIEW

4.000 One of the first steps in determining the appropriate accounting for share-based payments is to determine whether the award is classified as either equity or liability. Classification of awards as liability or equity is discussed in Section 3, *Classification of Awards as Either Liabilities or Equity*. For an equity-classified award, compensation cost is based on an award's grant-date fair value and is recognized over the employee's requisite service period or nonemployee's vesting period of the award. For a liability-classified award, the fair value of the award is remeasured at each financial statement date until the award is settled or expired. During the employee's requisite service period, compensation cost is recognized using the proportionate amount of the award's fair value that has been earned through service to date. For nonemployee awards, compensation cost is recognized over the vesting period, in the same manner as if the entity issuing equity had paid cash for the goods and/or services. For an equity-classified award, no additional compensation cost is recognized after the goods have been delivered or services have been rendered unless for some reason the award later becomes liability-classified. However, for a liability-classified award, in periods after the goods have been delivered or services have been rendered, the entire change in the fair value of a liability-classified award is recognized as compensation cost each period until the award is settled, expired or becomes equity-classified.

4.001 The employee's requisite service period and nonemployee's vesting period for both equity- and liability-classified awards is the period during which a grantee is required to provide goods or render services in exchange for the award. The service the employee is required to render during that period is referred to as the *requisite service*. The grant date for both employee and nonemployee awards occurs when there is a mutual understanding of the key terms and conditions of the award and all necessary approvals have been obtained.

4.001a Transactions with nonemployees in which share-based payment awards are granted in exchange for the receipt of goods or services may involve (1) one exchange at the point in time of the share-based payment awards for goods or services or (2) an exchange that spans multiple reporting periods. Furthermore, the terms of the exchange will dictate whether or not the quantity and terms of the share-based payment awards are known when the arrangement is established because of specific conditions, such as performance conditions, that may be stated in the agreement. Judgment is required in determining the period over which to recognize cost for nonemployee awards, or the nonemployee's vesting period. In addition, Topic 718 does not address the measurement period and attribution method for awards granted to nonemployees, except that it requires that an asset or expense be recognized (or reversed if previously recognized) in the same period, and attribution as if the grantor paid cash for the goods or services instead of paying with share-based payment awards. Topic 718 also does not address when employee or nonemployee awards should be capitalized versus expensed.

4.002 The employee's requisite service period and nonemployee's vesting period is determined by evaluating the conditions of the award. The award may have one or more of the following types of conditions: service, performance, market, or *other* conditions.

Awards with *other* conditions are liability-classified awards as discussed in Paragraphs 3.007 through 3.013.

4.003 To determine the amount of compensation cost to be recognized in each period, an entity makes an entity-wide accounting policy election for its employee and nonemployee share-based payment awards to either estimate the number of awards that are expected to vest or recognize the effect of awards for which the goods are not delivered or services are not rendered when the award is forfeited (that is, recognize the effect of forfeitures in compensation cost when they occur). The policy election applies to both equity-classified and liability-classified awards. If an entity elects to estimate the number of awards that are expected to vest, the estimate is adjusted up or down each period to reflect the current estimate of forfeitures and, finally, the actual number of awards for which the goods are delivered and services are rendered. Under both methods, compensation cost ultimately is recognized based on the number of awards for which the goods are delivered or services are rendered. We believe that an entity is permitted to make two entity-wide accounting policy elections for forfeitures (one for nonemployee awards and one for employee awards). See Q&A 4.15a.

4.004 Compensation cost recognized for equity-classified awards for which the grantee delivers the goods or renders services or purchases goods or services as a customer is not subsequently reversed, regardless of whether the award is exercised or becomes exercisable by the grantee. Conversely, compensation cost previously recognized is reversed if an award is forfeited prior to the completion of the employee's requisite service period or nonemployee's vesting period. For liability-classified awards, because they are remeasured to fair value until the award is settled, compensation cost may be reversed in periods subsequent to the completion of the employee's requisite service period and nonemployee's vesting period as a result of reductions in the fair value of the awards.

EQUITY-CLASSIFIED AWARDS

4.005 For equity-classified awards, compensation cost is measured based on the fair value of an award at the date of grant (referred to as *grant-date fair value*). The grant-date fair value of an equity-classified award is not adjusted for subsequent changes in the fair value of the underlying shares or other inputs used to estimate fair value of the award (see Section 2, *Measurement of Awards*, for a discussion of fair-value considerations). ASC paragraph 718-10-30-6

4.006 For employee equity-classified awards, compensation cost is recognized over the employee's requisite service period with a corresponding credit to equity (additional paid-in capital). The employee's requisite service period (see Paragraph 4.001) begins at the service inception date and ends when the requisite service has been provided. ASC paragraph 718-10-35-2

4.006a For nonemployee equity-classified awards, a grantor recognizes compensation cost for the goods acquired or services received in the same manner as if the company had paid cash for the goods or services. See Paragraph 4.086a for further discussion.

Service Inception Date

4.007 ASC Topic 718, *Compensation--Stock Compensation*, defines the service inception date as the date at which the employee's requisite service or nonemployee's vesting period begins. The service inception date usually is the grant date, but the service inception date may differ from the grant date. In certain situations, the service inception date may be prior to the grant date. This may occur when a grantee delivers goods or provides services needed to earn the award, but there has not been a mutual understanding of the terms of the award. The service inception date may be after the grant date in certain situations. ASC Section 718-10-20 and ASC paragraph 718-10-35-6

4.008 The service inception date can precede the grant date when all of the following conditions are met: (a) an award is authorized in accordance with the company's governance requirements, (b) service begins before a mutual understanding of the key terms and conditions of the award is reached and (c) either: (1) there is no future substantive service requirement at the grant date or (2) the award contains a market or performance condition that if not satisfied during the portion of the service period that precedes the grant date would cause the award to be forfeited. These conditions are illustrated in Q&A 4.4 and the subsequent examples. ASC paragraphs 718-10-55-108 and 55-109

4.009 As part of a year-end bonus, some entities provide compensation to employees in the form of both cash and equity awards. In some cases, the equity awards may contain a future service period whereas in other cases, there is no additional service requirement (i.e., the equity awards are immediately vested at the date of the grant). In these situations, the final amount of the cash bonus and the equity awards is determined after the end of the fiscal year (e.g., on February 1, 20X6 the amount of the cash and equity bonuses for the 20X5 year are determined and communicated). The cash bonus component of the award is subject to the recognition and measurement provisions of ASC paragraphs 710-10-25-9 through 25-11, and is accrued during the year preceding the ultimate determination of the cash bonus.

4.010 For employee awards, there will likely be varying degrees of specificity regarding the nature and amount of awards, the level of communication that has occurred with employees, and their understanding of the company's compensation program. At one end of the spectrum, the compensation strategy may have been formally approved by the compensation committee, be widely communicated to the employees, and publicly disclosed to the company's investors. This might be the result of a well-established compensation strategy to provide for total compensation to the employees based on a percentage of revenues, operating income, net income, or other performance measure that specifies within a relatively narrow range the portions of an employee's year-end bonus that are paid in cash and equity, and that plan may be well understood by the employees. At the other end of the spectrum, however, are companies whose annual compensation practices are not consistent in terms of a formula (or performance target) for determining the year-end bonus amount and/or the portions of the award settled in cash and equity. Between those ends of the spectrum are companies for which the compensation strategy

is well understood as a result of consistent past practice even though it is not formally documented.

4.011 In many of these situations, companies are not legally obligated to pay the cash bonus and/or grant the equity awards until the awards are finalized by the compensation committee the following year. Additionally, compensation committees may have varying degrees of discretion over the total monetary amount or number of equity awards to be given, for example, over the amount or percentage to be paid (i.e., the percentage of the operating income target to be paid in year-end bonuses) or over the portions of the award to be paid in cash and equity. However, these compensation arrangements are typically designed so that a specified monetary amount is settled in a combination of cash and equity. Because a portion of the award will be settled in equity, that portion is within the scope of ASC Topic 718.

4.011a For nonemployee awards that involve goods being delivered or services being rendered, there can be a vesting period that begins prior to the grant date, when (a) the award is authorized in accordance with the company's governance requirements, (b) the related services begin or the goods are provided before a mutual understanding of the key terms and conditions of the award is reached, and (c) either: (1) there is no future substantive service requirement at the grant date or (2) the award contains a market or performance condition that if not satisfied during the portion of the vesting period that precedes the grant date would cause the award to be forfeited. While it is possible for nonemployee awards to have a service inception date that begins prior to the grant date, in our experience, this scenario is less common for nonemployee awards than for employee awards.

Evaluating Whether Service Inception Date Precedes Grant Date for Employee Awards

4.012 In the situations described above, there would be no grant date for the equity portion of the award until the award is finalized by the compensation committee and the other conditions of a grant are met (see discussion of grant date beginning at Paragraph 4.027). However, there may be a service inception date for these awards. Determining whether a service inception date has been established is discussed in the following paragraphs. In many companies with compensation strategies that meet the criteria discussed above, service begins before a mutual understanding of the key terms and conditions is reached and, therefore, criterion (b) of ASC paragraphs 718-10-55-108 and 55-109 has been met (see Paragraph 4.008). However, criteria (a) and (c) require further analysis. ASC paragraphs 718-10-55-108 and 55-109

4.013 Criterion (A) - The Award Is Authorized. To determine that an award is authorized, it may be necessary for companies to establish an accounting policy based on its interpretation of conditions to be met. The interpretation should be consistently applied with appropriate disclosures about its application.

4.014 Under a *narrow* interpretation of authorization, consistent with ASC subparagraph 718-10-55-108(a), authorization is the date that all approval requirements are completed

(e.g., action by the compensation committee approving the award and determining the number of equity instruments to be issued). Under such a narrow interpretation, the service inception date may be the grant date and, in that case, no compensation cost would be recognized for the equity awards during the period preceding the grant date.

4.015 Under a *broad* interpretation of authorization, companies would consider the following factors in determining whether the award is authorized:

- Whether the board of directors or compensation committee has approved an overall compensation plan or strategy that includes the share-based-compensation awards; and
- Whether employees have a general understanding of the compensation plan or strategy, including an awareness that the employees are working towards certain goals and an expectation that awards will be granted (i.e., granting of the awards is dependent on the company achieving performance metrics and the employees understanding those performance metrics).

4.016 These factors are not intended to be all-inclusive and all relevant factors surrounding the company's policies and processes for granting awards should be considered in determining whether the award is authorized. Other information that may be appropriate to consider when evaluating the factors listed above include:

- Whether the compensation plan or strategy summarizes the process of how awards will be allocated to employees and how the number of awards or monetary amount of the awards will be determined (e.g., based on certain performance metrics that are defined or understood by the compensation committee either through formally authorized policy or established practice);
- Whether the compensation committee and the employees understand, based on written policy or established practice, the portion of the award to be settled in cash and in equity and the substance of the approval process to finalize the award, including the amount of discretion that the compensation committee uses to deviate from the compensation strategy previously approved and understood.

4.017 Criterion (C) – No Service Period Subsequent to Grant Date or Forfeiture if Performance Conditions Not Met. If it is determined that the authorization requirement has been met, it is necessary to assess whether either condition in criterion (c) of ASC paragraphs 718-10-55-108 and 55-109 has been met.

4.018 Retirement-Eligible Employees. The first condition of criterion (c) states that the award's terms do not include a substantive future requisite service condition that exists at the grant date. Many grants have a stated service requirement. However, if some of the recipients are retirement-eligible at the date of the grant, the service period is nonsubstantive (see discussion of the requisite service period for grants to retirement-eligible employees at Paragraph 4.058 and discussion of nonsubstantive service periods at Paragraph 4.062) and the first condition of criterion (c) would be met. Therefore, for a

company that has determined that the awards are (1) authorized, and (2) have no substantive future service requirement, it would be appropriate to conclude that the service inception date begins in the year before the grant date and, therefore, the equity portion of those awards with no substantive future service requirement should be accrued over that one-year period.

4.019 If a company determines the awards have not been authorized (e.g., under a narrow interpretation accounting policy for authorization), it would not have a service inception date that precedes the grant date for either its retirement-eligible employees or the rest of the employee population. In that situation, at the grant date a company would recognize as compensation cost the monetary amount of the equity awards for the retirement-eligible employees. For the remaining employees, the award would be recognized over the requisite service period as any other grant accounted for under ASC Topic 718.

4.020 Awards with a Service Requirement Subsequent to the Grant Date. The second condition of criterion (c) states that the award contains a market or performance condition that if not satisfied during the service period preceding the grant date, and following the inception of the arrangement, would result in forfeiture of the award. For awards that do not meet criterion (c)(1) (e.g., employees that are not retirement-eligible at the grant date), an analysis of whether the awards contain a market or performance condition is necessary. This analysis includes consideration of whether the award is based on the company's performance and if so, whether the performance measure is sufficiently defined on the authorization date to create a performance condition. As is the case with authorization, companies may need to make a separate accounting policy election to interpret this condition *broadly* or *narrowly*. A *narrow* interpretation of this criterion would be that unless the award itself (when granted) contains an explicit market or performance condition, the condition would not be met. A *broad* interpretation of this criterion would be that if the overall plan specifies that the amount of compensation to employees will be based on factors that constitute a market or performance condition as defined in ASC Section 718-10-20, this condition would be met.

4.021 Applying the definitions of performance and market conditions in ASC Topic 718 requires some specificity in the level of award that would be made and the parameters that would be considered in making the award. Judgment would need to be applied when the specific amount of the award varies from year to year but is within a reasonably narrow range to conclude that there is a sufficient degree of specificity in the award to meet the requirements of ASC Topic 718. However, under a broad interpretation of performance or market condition, it is not required that there be the same degree of specificity as would be needed to determine that there is a *mutual understanding required to achieve grant date*.

4.022 A company should consistently apply its accounting policy (broad vs. narrow) to criterion (a) for all of its employees. However, a company that elects a broad accounting policy for criterion (a) may still elect either a broad or a narrow interpretation for criterion (c)(2). Some companies may have a portion of the employee population (e.g., retirement-eligible employees) for whom criterion (c)(1) applies, while for other employees (e.g., employees that are not retirement-eligible) criterion (c)(2) applies. In

those situations, it is possible for a company to reach a conclusion that awards to retirement-eligible employees have a service inception date in advance of the grant date (because criterion (c)(1) is met) while non-retirement-eligible employee awards do not have a service inception date preceding the grant date (i.e., either because the company applies a narrow interpretation of criterion (c)(2) or applies a broad interpretation of that criterion but concludes that the award does not have a market or performance condition as contemplated by that criterion).

4.023 If a company elected a broad-broad accounting policy (i.e., broad interpretation of both criteria (a) and (c)(2)) for its non-retirement-eligible employees, then the requisite service period for the recognition of compensation cost would begin with the service inception date and end when the service condition is met. However, if the company elected a broad-narrow accounting policy (i.e., broad interpretation of criterion (a) and narrow accounting policy of criterion (c)(2)), then the requisite service period would begin at the grant date for the grants to non-retirement-eligible employees.

4.024 If a company elected a broad-broad accounting policy, this may affect the attribution policy election permitted by ASC paragraph 718-10-35-8, in relation to awards with graded vesting (see Paragraph 4.083 and Example 4.15).

Application of ASC paragraphs 718-10-55-108 and 55-109 to Liability- and Equity-Classified Awards

4.025 ASC paragraphs 718-10-55-108 (see Paragraph 4.008) and 55-109 do not distinguish between an equity-classified and a liability-classified award. Consequently, those criteria and the related accounting policy elections would apply to both equity-classified awards and liability-classified awards. An award that is a fixed monetary amount that will be settled in equity is within the scope of ASC Topic 718 and is liability-classified through settlement (see Paragraph 3.072). This is true regardless of whether the award is an employee or a nonemployee award, as the classification guidance under ASC Topic 718 is the same for both types of awards.

4.025a When the service date precedes the grant date, ASC paragraphs 718-10-55-108 and 55-109 provide that the recognition of compensation cost for periods before the grant date is based on the fair value of the award at the reporting dates that occur before the grant date. However, ASC paragraphs 718-10-55-108 and 55-109 do not address whether the corresponding credit for the cumulative compensation cost recognized (when the debit is to compensation expense) should be recognized to equity or to a liability account. We believe that when the service date precedes the grant date, and the award would otherwise be expected to be equity-classified at the future grant date, the credit side of the entries for the attribution of compensation cost and fair value adjustments for the award may be recognized either in equity or to a liability account. In either case, the adjustments to fair value would be recorded in earnings. Once there is a grant date for the equity-classified award, the award would remain in equity but no longer be remeasured. If the award is expected to be liability-classified at the grant date, then the credit side of the entries should be recorded to a liability account during the period preceding the grant date

(and thereafter). Also see Paragraph 4.036 for when grant date is achieved and the recognition of cumulative compensation expense.

Awards Settled in Cash and Equity at the Grantee's Election

4.026 Certain compensation arrangements may be structured so that the grantee can elect to settle the arrangement (a fixed monetary amount of compensation) either in cash or equity. Often in these arrangements, the cash portion is payable when the final amounts are determined, whereas the equity portion provides the grantee the right to receive shares with a fair value greater than if the cash election were made, but subject to a future service requirement. For employee awards, if the employee is not required to finalize the election until the end of the performance measurement period, the entire award will be treated as a cash bonus plan, which would be subject to ASC paragraphs 710-10-25-9 through 25-11. The result is the accrual of the entire amount over that period of the employee's service in a systematic and rational manner. If a grantee elects to receive a portion of the award in equity, the incremental value being awarded subject to a future employee requisite service or nonemployee vesting period would be recognized as a separate award over that period. The portion of the original award would be reclassified from liability to equity at that date. Subsequent *forfeitures* of the equity portion of the award would be accounted for as *clawbacks* when the equity award contains a vesting condition (see Paragraph 2.086). If, however, the grantee elects the split between equity and cash on or near the grant date, the cash bonus and equity components would be accounted for as separate awards with separate employee requisite service and nonemployee vesting periods.

Grant Date

4.027 A grant date occurs when the grantor and grantee have a mutual understanding of the key terms and conditions of the award. Additionally, on the grant date, the grantor becomes contingently obligated to issue equity instruments or transfer assets to a grantee who delivers goods or renders services or purchases goods or services as a customer. The grant date for an award is the date that a grantee begins to benefit from, or be adversely affected by, subsequent changes in the price of the grantor's equity shares. Awards made under an arrangement that are subject to shareholder approval are not deemed to be granted until the shareholder approval is obtained, unless that approval is considered perfunctory (e.g., management and the board of directors control enough votes to approve the arrangement). In addition, for employee awards, a grant date cannot occur until the recipient of the award meets the definition of an employee (see discussion about the definition of an employee beginning at Paragraph 1.005). ASC paragraphs 718-10-55-81 and 55-82 and ASC Section 718-10-20

4.028 The definition of the grant date provided in ASC Topic 718 requires that there be a mutual understanding by both the grantor and the grantee of the key terms and conditions of the award. As such, under ASC Topic 718, four conditions are essential to the grant date having occurred: (1) all necessary approvals have been obtained (including shareholder and board approval as necessary), (2) both the grantor and the grantee have a mutual understanding of the key terms and conditions of the award, (3) the grantee begins

to benefit from or be adversely affected by changes in the grantor's share price, and (4) the grantor is contingently obligated to issue equity instruments or transfer assets if the grantee delivers goods or renders services or purchases goods or services as a customer. All four conditions are required to be met for there to be a grant date.

4.029 Once the necessary approvals have been obtained, the grantor may be contingently obligated to issue shares or distribute assets (subject to the grantee delivering the goods or providing the services) and the grantee will typically begin to benefit from or be adversely affected by the changes in the grantor's share price. For employee awards, many employers will notify each employee of the terms and conditions of the awards that have been granted after the necessary approvals have been received. In that situation, notifying the employees is the last of the conditions to be satisfied, thereby resulting in the occurrence of the grant date pursuant to ASC Topic 718. In some cases, the award's terms and conditions may state the grant date is at a future date even though each of the four conditions have already been met. In such cases, the grant date may have occurred for accounting purposes prior to the stated grant date per the award's terms and conditions (see Example 4.0). For nonemployee awards, the notification typically is done at the time the agreement on the terms of payment for the goods or services is entered into between the entity and the nonemployee third party.

4.030 Because many companies had existing practices whereby, for example, employees were individually notified by their performance managers and those notifications did not occur at the same time, the FASB provided an accommodation to companies in determining the grant date in ASC paragraph 718-10-25-5. In accordance with ASC paragraph 718-10-25-5, the grant date may be deemed to be the date the award is authorized in accordance with the company's governance requirements (e.g., board approval) if the first, third, and fourth requirements specified in Paragraph 4.028 are met and both of the following conditions are met:

- The award is a unilateral grant and, therefore, the recipient does not have the ability to negotiate the key terms and conditions of the award with the grantor;
- The key terms and conditions of the award are expected to be communicated to an individual recipient within a relatively short time period from the date of approval. A "relatively short time period" is defined as the period an entity could reasonably complete all actions necessary to communicate the awards to the recipients in accordance with the company's customary practices. ASC paragraph 718-10-25-5

4.031 In assessing whether the notification occurs within a *relatively short time period* companies should consider:

- The time period over which notification occurs;
- The pattern of notifying grantees (i.e., are grantees notified at the same time or are they notified over a period of time and, if so, does the notification occur ratably or disproportionately over that period);

- The number and geographical location of grantees; and
- The specific steps needed to comply with the entity's customary practices.

4.032 To simplify the determination of the grant date, grantors should consider establishing processes to promptly notify grantees of the terms and conditions of their awards upon obtaining all necessary approvals. For example, employee notification can be done by e-mail to each employee describing the terms and conditions of the award or posting the information on a secure Web site where employees can access their information (in which case, employees can be notified of the date on which the information will be available).

Q&A 4.1: Determining the Grant Date – Approval Process Part I

Q. On March 1, 20X6, ABC Corp.'s board of directors approves the grant of 500,000 share options, where 400,000 share options are allocated to senior executives (the list of names of each of those executives was provided to the board), while 100,000 share options are approved as a pool and will be allocated to individual employees by management at a later date (no list of these employees was provided to the board). When is the grant date for 500,000 share options?

A. March 1, 20X6 is considered a grant date for the 400,000 share options granted to senior executives assuming that notification occurs within a relatively short time period and all other conditions for the grant date have occurred. However, the 100,000 share options approved by the board as available to grant to other employees will not be deemed to have been granted until management determines the number of share options (as well as other key terms and conditions) to be awarded to each employee. Consequently, there may be a different grant date for each of the employees depending on whether management makes the determination for all such employees at once or at different points in time.

Q&A 4.2: Determining the Grant Date – Approval Process Part II

Q. On March 1, 20X6, ABC Corp.'s board of directors approves the grant of 500,000 share options. In making the grant, the board did not have a list of grantees and the number of share options to be awarded to each employee. However, in making the grant, the board did determine that all employees in the senior executive group would receive 50,000 share options, all employees at the director level would receive 10,000 share options, and all employees at the manager level would receive 2,000 share options. Assuming that all other conditions for the grant date are met and that notification will occur within a relatively short time period, what is the grant date?

A. March 1, 20X6 is considered the grant date for the share options. It is not necessary for the board to have a complete list of the grantees and the number of awards granted to each grantee to have a grant. In this example, the steps that occur following the board

action are ministerial in nature (i.e., identifying which category an employee is in and assigning the board-approved number of share options to the employee based on his or her employment category). If, however, the steps that occur following the board action are more than ministerial, where management has discretion in determining the number of awards to be given to individual grantees, then the board action would not provide the basis for establishing the grant date because the key terms and conditions (the number of awards) for each employee would not have been established by the board action.

Q&A 4.2a: Determining the Grant Date – Approval Process Part III

Q. On January 1, 20X9, ABC Corp.'s management approves the grant of 5,000 share options to an employee. ABC's board of directors approves all individual awards, in accordance with the terms of the option plan, and management does not control the board. Also, based on historical stock option grant activity, the board will likely approve the award. On February 15, 20X9, the board meets and approves the award. Assuming that all other conditions for the grant date are met, what is the grant date?

A. February 15, 20X9, the date of board approval, is considered the grant date for the share options. While it may appear that the approval is perfunctory given the option grant approval history, since management does not control the board, the approval is not perfunctory. Therefore, a grant date would not be established until board approval is obtained.

Q&A 4.2b: Determining the Grant Date – Approval Process Part IV

Q. On January 1, 20X6, ABC Corp.'s Compensation Committee delegates authority to the CEO to grant employee stock awards for a twelve-month period. On February 1, 20X7 (after the delegated authority has lapsed), the CEO grants share-based payment awards to employees. On April 1, 20X7, the Compensation Committee retroactively extends the delegation period for another twelve months commencing January 1, 20X7. Assuming that all other conditions for a grant date are met, what is the grant date?

A. April 1, 20X7, the date that the Compensation Committee retroactively extends the delegation period, is considered the grant date. The CEO does not have the authority to approve the awards on February 1, 20X7, and therefore the awards are not authorized in accordance with ABC Corp.'s governance requirements until the date that the delegation period is extended.

Example 4.0: Grant Date for Employee Awards with Board Approval

On January 1, 20X5, the board of directors of ABC Corp. approves a grant of 200,000 nonvested shares to existing employees that vest after three years of service beginning on

March 1, 20X5. The board approval and award agreement state the awards are granted on March 1, 20X5. The awards' terms and conditions are communicated to the employees in a relatively short period of time after the January 1, 20X5 board meeting.

To determine the grant date, ABC evaluates the four conditions necessary to have a grant date as follows.

- The board of directors approved the grant on January 1, 20X5;
- Both the company and the employees have a mutual understanding of the key terms and conditions of the award on January 1, 20X5 (shortly thereafter);
- The employees begin to benefit from or be adversely affected by changes in the grantor's share price beginning on January 1, 20X5; and
- The company is contingently obligated to issue equity instruments or transfer assets if the grantee delivers the goods or renders services based on the award that was approved and communicated on January 1, 20X5.

Based on its analysis of the four conditions and facts and circumstances, even though the award states it is granted on March 1, 20X5, ABC determines the grant date is January 1, 20X5.

Q&A 4.3: Determining the Grant Date – Performance Condition

Q. On March 1, 20X6, ABC Corp. grants 100,000 share options to the Vice President of Sales. The award is communicated to the executive including the number of share options awarded, the exercise price, the service period, the contractual term, and the fact that the award contains an EPS target in order for the award to vest. However, the executive is not told the specific EPS target that needs to be achieved for the award to vest. The board agreed on the target prior to approval but the specific target level was not communicated to the executive. Is the communication of the EPS target to the grantee necessary for the grant date to occur?

A. Yes. The EPS target is one of the key terms and conditions of the award and, therefore, should be communicated to the grantee in a relatively short period of time to establish a mutual understanding of the award necessary to meet the definition of the grant date. Therefore, the grant date does not occur until the employee knows the specific EPS target assuming all other conditions necessary for a grant have already been met.

Q&A 4.4: Determining the Service Inception Date and Grant Date for Employee Awards

Q. On May 1, 20X5, ABC Corp. provides a written offer of employment to a prospective employee. In addition to salary and benefits, the offer includes a grant of 10,000 share

options that vest at the end of three years of service. The share options have an exercise price of \$15 per share option, which equals the market price of the shares at the date of the offer. The three-year service period begins on the date the offer is accepted. The individual accepts the employment offer on May 15 and starts work on June 1 (i.e., the individual first meets the definition of an employee on June 1). When is the service inception date and grant date?

A. Assuming that all necessary approvals have been received, both the service inception date and the grant date are June 1, 20X5. This is the first date that the award recipient begins providing services as an employee to ABC. Compensation cost would be measured on June 1, 20X5 and recognized over the period from June 1, 20X5 through May 15, 20X8.

If the award is subject to shareholder approval that is not obtained until after employment began, both the service inception date and grant date would be the date when all necessary approvals are obtained. For example, if shareholder approval is obtained on July 1, no compensation cost for the share option award would be recognized between June 1 and July 1. The compensation cost would be measured at the grant date (July 1) and would be recognized over the period from July 1, 20X5 through May 15, 20X8. ASC paragraph 718-10-55-111

There may be tax consequences to the recipient, the issuer, or both, for an award in which the grant date occurs after the exercise price of a share options is set. Factors that could affect this analysis include the recipient's level in the organization, whether the share options are in the money on the grant date, and whether the share options were intended to qualify as incentive stocks options for tax purposes. Consultation with a tax professional may be necessary to evaluate all of the facts and circumstances and the relevant tax guidance.

Q&A 4.4a: Stock Option Repricing and Whether the Service Inception Date precedes the Grant Date for Employee Awards

Background

ABC Corp. has outstanding employee stock option awards, with an exercise price of \$10 per option, which were issued in 20X0 and within one month of ABC's IPO. In 20X2, post-IPO, ABC's shares are trading at \$5 per share resulting in the stock options being out of the money. Given the decline in share price, on November 1, 20X2, management of ABC announced repricing for both vested and unvested stock option awards, which requires stockholder approval. Management has no ability to further revise the repricing terms once stockholder approval is obtained. Required stockholder approvals are received on November 30, 20X2. Under the approved terms, all outstanding stock options, vested and unvested, will be repriced based on the price of shares on January 31, 20X3 ('repricing date'), i.e., 2 months after the announcement date. Stock option holders with vested awards will become eligible to participate and take advantage of the stock option

repricing only if they remain in service through the repricing date. If they do not remain in service through January 31, 20X3, they can retain all of their vested awards at the original exercise price. No changes are made to any of the service vesting conditions for unvested awards. No other or new vesting conditions are added to either vested or unvested awards.

Q1. Is the service inception date for the modification of the stock options on November 1, 20X2, November 30, 20X2 or January 31, 20X3?

A1. Under Topic 718, the service inception date is the beginning of the requisite service period, and usually is the grant date but may be different (earlier) than the grant date. Therefore, the service inception date for the modification is November 30, 20X2 because the full authorization and approval by stockholders is obtained on November 30, 20X2 and management cannot revise the repricing terms after this date; November 30, 20X2 is the beginning of the requisite service period.

Q2. What is the grant date?

A2. As described in Paragraph 4.028, all four of the following conditions are required to be met for there to be a grant date:

1. All necessary approvals have been obtained (including shareholder and board approval as necessary) – achieved November 30, 20X2 (see Q1).
2. Both the grantor and the grantee have a mutual understanding of the key terms and conditions of the award – achieved November 30, 20X2 (see Q1). While the revised exercise price is not fixed on November 30, 20X2, there is a mutual understanding of the key terms and conditions of the award, including the date that the repricing will occur.
3. The grantee begins to benefit from or be adversely affected by changes in the grantor's share price – achieved January 30, 20X3 (date the repricing is set).
4. The grantor is contingently obligated to issue equity instruments or transfer assets if the grantee delivers goods or renders services or purchases goods or services as a customer – achieved November 30, 20X2.

The third criterion is not met until January 30, 20X3 because the exercise price is not established until then, and grantees are unaffected by any of the stock price changes prior to this date. Accordingly, the grant date for Topic 718 purposes is January 30, 20X3.

Q3. Does the service inception date precede the grant date for the vested or unvested awards being repriced?

A3. The modification to reprice the stock options does not change any of the existing service vesting conditions nor does it introduce any new service vesting conditions.

For the vested awards, since there are no future substantive service requirements after the January 30, 20X3 grant date (see Paragraphs 4.012 and 4.017) and the modification is authorized, along with a mutual understanding of the terms and conditions on November 30, 20X2, the guidance related to service inception date preceding the grant date is considered applicable. Accordingly, all vested awards expected to be repriced (i.e., vested awards held by stock option holders who are expected to remain in service through the repricing date) will be measured at fair value on the November 30, 20X2 modification date and remeasured until the January 30, 20X3 grant date with all fair value changes being recorded in earnings. See Paragraph 4.025a.

Vested awards held by stock option holders who are **not** expected to remain in service through the repricing date will not be modified and accordingly, there is no modification accounting for these awards.

Due to lack of a fixed exercise price, an alternative valuation technique may be warranted (e.g., lattice model). See 2.097.

For the unvested awards, we believe there are two possible accounting conclusions:

- (a) View 1 - Apply the same accounting treatment as described above for vested awards to recognize them as modified on November 30, 20X2 with the awards remeasured until the January 30, 20X3 grant date. While the criteria for applying the service inception date preceding the grant date guidance is not met (i.e., the substantive future requisite service condition – see Paragraph 4.020 – may still exist on the January 30, 20X3 grant date for the unvested awards), we believe this view is an acceptable approach because the third requirement for the grant date criteria (see Q2) is still not met until January 30, 20X3 for the unvested awards, while service related to the modified awards has begun.
- (b) View 2 - Continue recognizing expense from the original stock option award until the January 30, 20X3 grant date and recognize the the modification once the unvested stock options are repriced. We believe this view is an acceptable approach because the service inception date preceding the grant date guidance is not met, and therefore the unvested awards' modification can be accounted for in its entirety on January 30, 20X3.

Example 4.1: Service Inception Date and Grant Date for Employee Awards – Part I

Background

On January 1, 20X5, ABC Corp. grants a senior executive 200,000 nonvested shares that vest after two years of service. The award is subject to shareholder approval that is expected to occur at ABC's next annual shareholders' meeting on May 1, 20X5. The per-share price of ABC's stock is \$10 on January 1, 20X5 and \$15 on May 1, 20X5.

Compensation cost for quarter ended March 31, 20X5

No compensation cost would be recognized because the service inception and grant date cannot occur prior to shareholder approval (unless such approval is perfunctory). In this example, the service inception date and grant date are May 1, 20X5 when shareholder approval is obtained.

Compensation cost for quarter ended June 30, 20X5:

On the grant date, there are only 20 months remaining in the requisite service period. All compensation cost is attributed to that period and is recorded prospectively. A cumulative entry for the prior 4 months is not recorded.

| | |
|--|--------------------------|
| Number of nonvested shares | 200,000 |
| Share price on May 1, 20X5 | \$ <u>15</u> |
| | \$ 3,000,000 |
| | |
| Requisite service period in months (May 1, 20X5 through December 31, 20X6) | 20 |
| Compensation cost per month | \$ <u>150,000</u> |
| May 1, 20X5 through June 30, 20X5 (in months) | 2 |
| Second quarter compensation cost | \$ <u><u>300,000</u></u> |

Example 4.1a: Service Inception Date and Grant Date for Employee Awards – Part II

Assume the same facts as in Example 4.1, except that the award vests 50% each year over the two-year service period.

Compensation cost for quarter ended June 30, 20X5:

On the grant date, there are only 20 months remaining in the requisite service period. All compensation cost is attributed to that period and is recorded prospectively. A cumulative entry for the prior 4 months is not recorded.

| | |
|--|----------------------------|
| Number of nonvested shares | 200,000 |
| Share price on May 1, 20X5 | \$ <u>15</u> |
| | \$ <u><u>3,000,000</u></u> |
| | |
| Compensation expense for May 1, 20X5-December 31, 20X5 | \$ 1,500,000 |
| Requisite service period in months (May 1, 20X5-December 31, 20X5) | 8 |
| Compensation cost per month | \$ 187,500 |
| Second quarter compensation cost (2 months for May and June 20X5) | \$ 375,000 |
| Compensation expense for 20X6 | \$ 1,500,000 |

Since the first tranche of options vest on December 31, 20X5, at least \$1,500,000 of cumulative compensation cost is recorded over the 8 months from May 1, 20X5-December 31, 20X5. This is because the amount of compensation cost recognized at any date must at least equal the portion of the grant-date fair value of the award that is vested at that date. The remaining \$1,500,000 is recognized over the final twelve months of the vesting period for the 12 months of 20X6. ASC paragraph 718-10-35-8.

4.033 A share-based payment plan with employees may provide for payout of all unallocated shares at the end of the plan's term or on occurrence of a specified event (e.g., IPO or change in control). This is often referred to as a *last-man-standing* plan because if only one employee remains on the payout date, that employee is entitled to all of the remaining shares of the plan. An entity would not begin accounting for those unallocated shares at the inception of the plan, because the individual employees do not yet know the number of units to which they will be entitled, and therefore the requirements for a grant date are not met. Some have argued that the requirements for service inception are met at plan inception because the award is authorized; the employee has begun to be affected by changes in the share price; and at the grant date, there will be no substantive future requisite service condition. However, this last conclusion is predicated on an assumption that the grant date will occur only at the final maturity of the plan. This may not be the case because unallocated shares can be granted at any time to any current or future employee. If this occurs, there would be a substantive future requisite service condition for those awards. Consequently, the compensation cost is recognized over the requisite service period beginning as of the grant date. The grant-date fair value for last-man-standing plans should be determined at each grant date rather than at the inception of the plan, including for shares reallocated to employees resulting from other employees' forfeitures. If shares remain unallocated for the entire time the plan exists, there would be a one-time recognition of compensation cost at the maturity of the plan for the remaining unallocated shares.

Q&A 4.5: Accounting for Shares Authorized In A Share-Based Payment Plan When All Shares Must Be Paid Out

Q. ABC's share-based payment plan provides for the grant of 10 million shares. At plan inception, 6 million shares are allocated to existing employees and the remaining 4 million shares are reserved for additional grants to existing employees or for future new employees. The plan provides for all 10 million shares to be distributed at the earlier of an IPO or 7 years from the plan's inception. ABC's board has discretion on the final allocation of unallocated shares among the remaining employees at the end of the plan (i.e., on occurrence of an IPO or 7 years). How should ABC account for the shares authorized under the plan?

A. ABC should account for the 6 million allocated shares in accordance with ASC Topic 718, assuming all conditions for a grant have been met at plan inception. ABC would account for forfeitures as they occur or estimate forfeitures in accordance with its policy

for forfeitures. The requisite service period for those shares would be 7 years, because it is improbable that an IPO will occur sooner. If an IPO occurs, ABC would accelerate the compensation cost for the unrecognized compensation cost of the allocated shares.

ABC should not begin accounting for the 4 million unallocated shares because neither the requirements for a grant date nor a service inception date have been met. Compensation cost would be measured for the unallocated shares based on the fair value of the shares on the date that the shares are granted to employees. Similarly, if some of the allocated shares are forfeited and then reallocated to other employees, ABC should measure compensation cost for the reallocated shares based on the then-current fair value of the shares. In both cases, the compensation cost would be recognized prospectively over the period from the allocation/reallocation grant date to the 7 year anniversary of the plan.

4.034 In certain situations the service inception date will be after the number of shares and the exercise price are specified by the company. This may occur when substantive acceptance of the award is required or where the grantee needs to fulfill other criteria to qualify for an employee award.

Example 4.2: Option Offer before the Service Inception and Grant Date

An attorney who performs outside legal services for an entity under a consulting contract accepts an offer to become the entity's in-house counsel on completion of the entity's initial public offering. On April 1, the entity grants the attorney share options to purchase 48,000 shares of common stock at the fair value of the entity's common stock on that date. The share options will vest over a four-year period commencing on April 1. The award is conditional on the attorney beginning work with the entity as an employee. The fair value of the entity's common stock is \$10 on April 1. The attorney begins employment three months later when the stock price is \$25. The attorney is paid for services as a consultant and none of the award is associated with those services.

The service inception date and grant date is not until the commencement of employment because the attorney would forfeit the award if he/she did not become an employee. As such, the grant-date fair value would be measured using an exercise price of \$10 and a stock price of \$25. The compensation would be recognized over the 45-month service period commencing with the date that the attorney began employment, with no cumulative entry for the prior 3 months.

There may be tax consequences to the recipient, the issuer, or both for an award in which the grant date occurs after the exercise price of a share option is set. Factors that could affect this analysis include the recipient's level in the organization, whether the share options are in the money on the grant date, and whether the share options were intended to qualify as incentive stock options for tax purposes. Consultation with a tax professional may be necessary to evaluate all of the facts and circumstances and the relevant tax guidance.

4.035 While the service inception date and grant date are usually the same, the service inception date precedes the grant date if each of the following conditions is met:

- An award is authorized;
- Service begins before a mutual understanding of the key terms and conditions of the award is reached; and
- *Either* of the following conditions applies: (1) the award's terms do not include a substantive future requisite service condition that exists at the grant date, *or* (2) the award contains a market or performance condition that results in forfeiture of the award if it is not satisfied during the service period preceding the grant date.

4.036 If the service inception date precedes the grant date, the award's fair value is remeasured at each reporting date until the grant date occurs. On the grant date, if equity-classified, the award's fair value is fixed and the company would no longer remeasure the award. For equity-classified awards, the cumulative amount of compensation cost based on the fair value at the grant date is recognized. If the award is liability classified, the fair value would continue to be remeasured at each reporting date until settlement occurs. An entity would apply the same policies for awards with graded vesting as discussed in Paragraphs 4.080-4.080b. ASC paragraphs 718-10-35-6 and 55-112

Example 4.3: Award Does Not Include a Substantive Future Service Condition at the Grant Date

On January 1, 20X6, ABC Corp. communicates to an employee that an award of 10,000 fully vested share options will be granted on December 31, 20X6, with an exercise price equal to ABC's share price on December 31, 20X6 if the recipient is still employed on that date. All necessary approvals for the award have been obtained on January 1, 20X6.

The award's terms call for the exercise price to be set equal to the share price 12 months forward and, as a result, the grant date for the award is December 31, 20X6 when the employee begins to benefit from, or be adversely affected by, changes in the price of ABC's shares. The service inception date is January 1, 20X6 because there is no substantive future service after the grant date (December 31, 20X6). As a result, the requisite service period is from January 1, 20X6 (the service inception date) through December 31, 20X6. ASC paragraph 718-10-55-113

Prior to the grant date (December 31, 20X6), the fair value of the award would be remeasured at each reporting date using an appropriate option-pricing model. Compensation cost would be recognized as shown below:

| | Fair Value of Share Options at the End of Period | Requisite Service Provided | Year-to-Date Compensation Cost | Quarterly Compensation Cost (Benefit) |
|----|--|----------------------------|--------------------------------|---------------------------------------|
| Q1 | \$50,000 | 1/4 | \$12,500 | \$12,500 |
| Q2 | 140,000 | 2/4 | 70,000 | 57,500 |
| Q3 | 80,000 | 3/4 | 60,000 | (10,000) |
| Q4 | 120,000 | 4/4 | 120,000 | 60,000 |

If the terms of the above award had provided for vesting on December 31, 20X8, the service inception date would not occur before the grant date of December 31, 20X6, because there would be a substantive future requisite service condition at the grant date (two additional years of service). As a result, no compensation cost would be recognized during 20X6. In that circumstance, compensation cost would be recognized in 20X7 and 20X8 over the two-year requisite service period, commencing on the grant date and service inception date of December 31, 20X6. No cumulative entry would be recorded in 20X7 for the service provided in 20X6. ASC paragraph 718-10-55-113

Example 4.4: Award Contains a Performance Condition That if Not Satisfied before the Grant Date Results in Forfeiture of the Award

On January 1, 20X6, ABC Corp. gives a grantee an authorized award of 4,000 share options that vest on December 31, 20X7 (two-year service requirement). The exercise price will be set on December 31, 20X6. However, the award will be forfeited if ABC does not meet its 20X6 earnings target.

In this example, the grantee earns the right to the award if the 20X6 earnings target is met (a performance condition) and the grantee delivers the goods or renders services during 20X6 and 20X7. The grant date has not yet occurred because there is not a mutual understanding of the terms (the exercise price has not been established). Because the award contains a performance condition that if not satisfied before the grant date results in forfeiture of the award, the requisite service (for an employee award) or vesting period (for a nonemployee award) is from January 1, 20X6 (the service inception date) through December 31, 20X7. Before the grant date (December 31, 20X6), the fair value of the award (using an option pricing model) is remeasured at each reporting date. ASC paragraph 718-10-55-114

Example 4.5: Service Inception Date Precedes the Grant Date – Award with Multiple Service Periods

On January 1, 20X6, ABC Corp. enters into an employment contract with its new CEO, such that the CEO will be issued 2,000 fully vested share options at the end of each of the next five years. The exercise price of each tranche will be equal to the market price at the date of issuance (December 31 of each year).

The grant date for each tranche is December 31 of each year because before that date there is no mutual understanding of the terms of the award (the exercise price is not set until December 31 of each year). Because no future service requirement will exist at the grant date (each tranche is fully vested at its grant date), the service inception date precedes the grant date. Each tranche is accounted for as a separate award with a service inception date of January 1 of each year and a requisite service period of one year. Prior to the date of grant (December 31 of each year), the fair value of the award would be remeasured at each reporting date. ASC paragraph 718-10-55-98

Example 4.6: Grant Date Precedes the Service Inception Date – Performance Award with Multiple Service Periods

On January 1, 20X6, ABC Corp. issues its CEO 20,000 share options with an exercise price of \$20 per share option. If annual performance targets are achieved, 5,000 share options will vest at the end of each of the next four years. All of the performance targets are established as of the date the award is issued. Vesting of each tranche is independent of the satisfaction of the annual performance targets for the other tranches.

The grant date for each tranche is January 1, 20X6 because there is a mutual understanding of the terms of the award (the exercise price and performance condition are set for each tranche). Each tranche of 5,000 share options has its own service inception date of January 1 of each year and is accounted for as a separate award with a requisite service period of one year, based on the following: 1) each tranche has a separate annual performance condition (that is not tied to the other tranches), 2) the ability for each tranche to vest is not dependent on service in any of the other years, and 3) failure to satisfy the performance condition for any one tranche has no effect on the vesting of the other tranches. ASC paragraphs 718-10-55-93 and 55-94

Example 4.7: Service Inception Date Precedes the Grant Date – Performance Award Based on Future Net Income

On January 1, 20X6, ABC Corp. issues share options with the following terms: (1) number of share options to be granted is the number of share options whose aggregate fair value using a Black-Scholes-Merton model equals 10% of net income for the year ended December 31, 20X6; (2) the exercise price will be equal to the market price of the stock on the grant date; and (3) the share options vest 20% each year beginning on January 1, 20X7 and ending on December 31, 20Y0.

The grant date for the share options is unknown until some point after January 1, 20X7, after completion of the year and closing of the books, because the number of share options to be received under the arrangement is a key term that is required before the employee and employer can have a mutual understanding of the key terms of the award. Because (1) the award is authorized under ABC's governance requirements, (2) the

service begins before a mutual understanding of the key terms and conditions of the award is reached, and (3) the award contains a performance condition that if not satisfied during the portion of the service period that precedes the grant date, would cause the award to be forfeited, the service inception date precedes the grant date. The service inception date would be January 1, 20X6 and the grant date would be the date after January 1, 20X7 when the number of share options to be issued has been determined.

Example 4.8: Grant Date Is Service Inception Date – Performance Award with Multiple Service Periods – Part I

Assume the same facts as in Example 4.6, except that the vesting of each tranche depends on the satisfaction of the performance targets for the previous tranches (e.g., failure to achieve the 20X6 performance target would result in the forfeiture of all awards).

The grant date and service inception date for each tranche is January 1, 20X6 because there is a mutual understanding of the terms of the award (the exercise price and performance condition is set for each tranche). However, each tranche of 5,000 share options has its own requisite service period over which compensation cost is recognized (e.g., the 20X6 tranche has a one-year service period, the 20X7 tranche has a two-year service period, and so on). ASC paragraph 718-10-55-96

Example 4.9: Grant Date Is Service Inception Date – Performance Award with Multiple Service Periods – Part II

Assume the same facts as in Example 4.6, except that the annual performance target of each tranche is not established until January of each year.

The grant date and service inception date for each tranche would be in January of each year because there would not be a mutual understanding of the terms of the award (the performance condition is set for each tranche). Each tranche of 5,000 share options would have its own one-year requisite service period beginning January of each year when the performance target is established. ASC paragraph 718-10-55-95

EFFECT OF COMPENSATION COMMITTEE DISCRETION CLAUSES ON DETERMINING GRANT DATE

4.037 A share-based payment arrangement may provide a compensation committee or an equivalent body with discretion to amend the terms of the award at any time before vesting of the award. Discretion clauses provide different degrees of latitude to the compensation committee to amend the terms of awards. For example, a clause may require a review and reconfirmation of the mathematical accuracy of a calculation required by the terms of the share-based payment arrangement at the vesting date to confirm the vested entitlement. In this case, there is little or no substantive discretion available to the compensation committee. In other instances, the clause may provide the

compensation committee with discretion to determine if conditions of the award are met or whether the resulting compensation is appropriate. For example, the terms of the award may state that “notwithstanding the achievement of the established performance conditions, the award shall not vest until the compensation committee has made a determination that the entity’s overall performance during the period of the award was satisfactory.”

4.038 Discretion clauses can affect the determination of the grant date. We believe that when the terms of a share-based plan provide the compensation committee with discretion to amend the terms of a share-based payment arrangement, determining whether there is (i) a mutual understanding of the key terms and conditions of the award between the grantor and grantee, (ii) the grantee begins to benefit from or be adversely affected by the changes in the grantor’s share price, and (iii) the grantor is contingently obligated to issue equity instruments or transfer assets if the grantee delivers goods or renders services, or purchases goods or services as a customer, should be based on an analysis of the degree of subjectivity (discretion) afforded the compensation committee as well as the factors over which the compensation committee has discretion.

4.039 If the discretion clause provides the compensation committee with significant subjectivity such that there is no shared understanding of the terms and conditions before finalization of the award, then there would not be a grant date until the period for exercising the discretion has passed. In those situations, and if the conditions for the service inception date to precede the grant date are met (see Paragraphs 4.008 – 4.019), the award is remeasured throughout the performance period until there is a grant date. Otherwise, there would be no accounting until a grant date was established, which would affect both the measurement of the award and the attribution period.

4.040 Clauses that would be invoked only *with cause* or in exceptional circumstances generally would not delay grant date. For example, a clause that is intended to be invoked with cause may be in relation to a specific employee action such as a determination that the individual employee engaged fraud or other gross misconduct would not delay a grant date. Similarly, a provision that a change will be made to a performance condition intended to maintain the same degree of difficulty following a major acquisition or disposition would not delay a grant date.

4.041 Arrangements may contain clauses that are largely objective and may give little, if any, discretion to either the grantee or the compensation committee. Such clauses that largely are objective do not result in a delay in grant date and subsequent invocation of the clause does not result in modification accounting.

4.042 If the discretion clause does not result in a delay in grant date, then it is necessary to consider whether invocation of the clause would result in modification accounting. Modification accounting is applied whenever there is a change in the fair value, vesting conditions or classification of an award. Clauses that include predetermined adjustments are typically designed to keep grantees in the same equity ownership position pre- and post-adjustment. Modification accounting generally would be applied if a discretion clause is invoked for changes other than predetermined adjustments; for example, for

changes in capital structures or the recalculation of performance requirements. However, a comparison of changes in fair value, vesting conditions and classification is done for *any* clause invocation to determine if modification accounting should be applied, as the fair value may change, even when there is a predetermined adjustment, and result in modification accounting. For example, if the predetermined adjustment was intended to retain the same ownership percentage of the entity (i.e., a make-whole provision), and the underlying value of the entity changes, that would result in incremental fair value. See section 5.

4.043 An arrangement that contains a nondiscretionary and a discretionary component should be evaluated and accounted for as separate awards if the terms and conditions of the components are clearly different for each component. For example, an employee is granted 100,000 share options that cliff vest four years from the grant date. On the vesting date the compensation committee may decrease or increase the award by up to 20,000 share options. This decision is to be made based on the compensation committee's decision that the employee's annual performance appraisals have been satisfactory. In this case, the nondiscretionary and discretionary components should be evaluated separately as the terms and conditions of the award are clearly different for each component. Therefore, in this situation a grant date is established for the nondiscretionary 80,000 share options.

4.044 The discretionary clause provides the compensation committee with significant discretion regarding whether to withhold/cancel certain awards or grant additional awards. For example, the compensation committee has not communicated what factors will be considered in determining whether the employee's performance appraisals have been satisfactory but has acknowledged the assessment is inherently subjective. In this case, there is no shared understanding of the terms and conditions for the awards to which the discretionary clause relates. Therefore, a grant date is not established for that portion of the award until the discretionary clause is exercised or has lapsed. However, for that portion of the award, the service inception date precedes the grant date as the criteria in ASC paragraph 718-10-55-108 are met (also see Paragraphs 4.008 – 4.019). The share options affected by the discretionary clause are remeasured to fair value throughout the performance period until a grant date is established, and the measurement guidance in ASC Topic 450, *Contingencies*, is followed in determining the best estimate of the likely number of share options to be earned each accounting period. Any changes in the estimate of the number of share options along with changes in the fair value of the share options and additional attribution is recorded each period to true-up the cumulative compensation cost to the current best estimate until the discretionary clause is resolved by the compensation committee or lapses.

Q&A 4.5a: Effect of Discretionary Clause on Clawback Feature

Background

ABC's share-based payment plan provides for the grant of performance based awards. The performance conditions used to determine the amount of the award vested for

grantees are ABC's revenue amounts and EBITDA. The plan provides the compensation committee with a discretionary clause such that the number of shares issued may be adjusted downward, at the discretion of the compensation committee, in the event of negative total shareholder return (as defined in the grant agreement).

Historically, the compensation committee has never exercised its right under the discretionary clause. Grantees are made aware of the discretionary clause in the materials provided to them in the acceptance letter for the grant.

Q. What is the effect, if any, of the discretionary clause on the accounting for the award?

A. Typically, the objectivity of both the trigger and the consequences for the clawback are evaluated. In this case, the trigger for the clawback is sufficiently objective (the calculation of negative shareholder return), so that the grantee understands what event would trigger the clawback. While the compensation committee retains discretion in determining if and how much would be clawed back, there is a mutual understanding of the key terms and conditions of the awards.

However, this discretionary clause acts more akin to a contingent clawback feature (rather than a contingent market condition – see Paragraph 4.116), which would be triggered if there is negative shareholder return. If there is a negative shareholder return, then the amount of the award that has vested based on achievement of the performance criteria could potentially be reduced by the compensation committee, at its discretion. Contingent clawback features are accounted for if and when the contingent event occurs. Therefore, the grantee will account for the award as it would any other award with performance conditions and the effect of the discretionary clause would only be accounted for using the guidance on clawback features if and when the compensation committee triggered the clause. See discussion at beginning at Paragraph 2.086.

DISCRETIONARY CLAWBACK PROVISIONS (INCLUDING EFFECT OF DODD-FRANK WALL STREET REFORM AND CONSUMER PROTECTION ACT)

4.045 SEC Exchange Act Rule 10D-1 (Rule 10D-1) implements the provisions of The Dodd-Frank Wall Street Reform and Consumer Protection Act (Dodd-Frank Act). Rule 10D-1, and the ensuing listing standards of the national securities exchanges, require an SEC issuer to develop, implement and disclose a compensation recovery policy that 'claws back' incentive-based compensation (i.e., cash bonuses or share-based payment awards) paid to current or former executive officers when certain accounting restatements¹ correct an error in previously issued financial statements and change one or more financial reporting measures that affect the amount of such compensation.

4.045a An SEC issuer's recovery policy must be designed to claw back erroneously awarded compensation received during the three completed fiscal years immediately preceding the date it is determined that the issuer is required to prepare an accounting restatement. The amount subject to clawback, or recoverable amount, equals the excess of what was paid to executive officers (as defined in the rules) over what would have been paid based on the restated results over the three-year look-back period. With very

limited impracticability exceptions, SEC issuers are not permitted to settle for less than the full recoverable amount. If an SEC issuer has a measure that is tied in part to attaining a financial reporting measure and in part to attaining an operational goal, the SEC issuer would need to assess the effect of the restatement on the portion that was tied to attaining the financial reporting measure. Rule 10D-1, and the ensuing listing standards, are prescriptive in that they dictate the minimum requirements the exchanges must adopt and SEC issuers must implement.

4.046 ASC Topic 718 describes clawbacks and other provisions that usually are triggered by noncompete, nonsolicitation, or fraudulent behavior provisions, that require the grantee in certain situations to return the share options, shares, or gains realized thereon either for no consideration or net of amounts paid by the grantee. A clawback provision that an entity implements only to comply with Rule 10D-1 and the listing standards meets this definition, and is not treated as a modification (see Section 5). Clawback features are not considered in determining the grant-date fair value of the award or in recognizing compensation cost. Rather, they are accounted for only if the contingent event occurs, recognizing the consideration received from the former grantee in the appropriate balance sheet account (treasury stock if the entity receives its shares; cash if cash is collected instead) and a credit in the income statement. Any excess fair value over the compensation cost is recorded to additional paid-in capital. If a company invokes a clawback for an equity-classified award, it would reverse the lesser of previously recorded compensation cost or the current fair value of the returned share-based payment. See Paragraph 2.086 for additional guidance about the effects of clawback provisions on the accounting for share-based payments. ASC paragraphs 718-10-55-8 and 718-20-55-85

4.047 Although not required by Rule 10D-1, some companies may include discretionary clauses as part of their clawback provisions. Discretionary clauses provide latitude to the compensation committee to claw back a previously vested award, even in the absence of a financial restatement. If the discretionary clause provides the compensation committee with significant subjective bases on which to claw back an award, there may be no shared understanding of the terms and conditions, and the award would not have a grant date until the period for exercising the discretion passed. For example, if the compensation committee has discretion to decide whether a clawback is triggered or what the consequence of the clawback would be, based on a subjective evaluation of the quality of earnings or an individual's job performance, the employee would not be in a position to understand how those factors ultimately would be evaluated. In those situations, a grant date is not established and the facts and circumstances would need to be evaluated to determine how to account for an award before the grant date. Another variation of a discretionary clawback that some companies have proposed is based on an assessment that an individual employee acted in a manner that subjected the company to excessive financial risk, with only vague definitions about how the occurrence of that risk would be measured and/or what the consequences would be if the company determined that the risk created by the employee's action was in fact excessive. In both of these circumstances, if a grant date was deemed to not have been established, the company considers ASC paragraph 718-10-55-108 for employee awards, which describes the conditions that require designation of service inception before the grant date (also see Paragraphs 4.008 –

4.019 for further discussion on when the service date precedes the grant date). If those conditions are met (which is likely), the award would be remeasured throughout the service period until there is a grant date. In the less likely scenario that those conditions are not met, there would be no accounting until a grant date was established, which would affect both the measurement of the award and the attribution period. For nonemployee awards, these conditions would be considered as well, and if met, the award would be remeasured throughout the vesting period until there is a grant date.

See discussion beginning at Paragraph 4.037 for the impact on discretionary provisions. Also see Paragraph 2.086.

4.048 – 4.052 Not used.

Requisite Service or Nonemployee Vesting Period

4.053 The initial determination of the requisite service period is made at the grant date (or the service inception date, if it precedes the grant date) based on an analysis of the service, performance, or market conditions contained in the award. The requisite service period may be stated, either explicitly or implicitly, from the terms of the award, or it may need to be derived from certain valuation techniques used to estimate the fair value of the award. At times, judgment is required in determining the employee's requisite service period. See Paragraph 4.066. ASC paragraphs 718-10-30-25 and 30-26, 55-77

4.053a Similar to the employee requisite service period, the determination of the nonemployee vesting period is made at the grant date (or the service inception date, if it precedes the grant date) based on an analysis of the service, performance, or market conditions (or a combination thereof) that are explicit or implicit in the terms of the award. If not stated explicitly or implicitly in the terms of the award, it may need to be derived from certain valuation techniques used to estimate the fair value of the award. At times, judgment is required in determining the nonemployee vesting period. The difference between a nonemployee vesting period and an employee requisite service period is that the nonemployee compensation cost is attributed over the vesting period in the same manner as it would be if the grantor had paid cash for the goods or services instead of granting share-based payment awards.

SERVICE CONDITION

4.054 A service condition is a requirement for the employee to achieve a specified duration of employment to earn the award, or the nonemployee to deliver goods or render services to the grantor over a vesting period. Awards with a service condition contain an *explicit* service period. An explicit service period is specifically stated as the required service period needed to earn the award. For example, an award that vests after four years of service has an explicit service period of four years.

4.055 ASC Section 718-10-20 defines a service condition as:

A condition affecting the vesting, exercisability, exercise price, or other pertinent factors used in determining the fair value of an award that depends solely on an

employee rendering service to the employer for the requisite service period or a nonemployee delivering goods or rendering services to the grantor over a vesting period. A condition that results in the acceleration of vesting in the event of a grantee's death, disability, or termination without cause is a service condition.
ASC Section 718-10-20

4.056 The employee's requisite service period for an award that has only a service condition is the explicit service period, unless there is clear evidence to the contrary. If vesting or exercisability of an award requires the employee to provide any future service, no portion of the compensation cost is attributed to prior periods. ASC paragraph 718-10-55-67

Q&A 4.6: Grant for Past Service with Future Vesting Period

Q. An entity's board of directors grants a large one-time award of share options to certain employees. The board resolution states that the share options are granted in recognition of the employees' past service to the entity; however, the share options vest over the next two years. Over what period should the entity recognize compensation cost for this award?

A. The employee requisite service period is the two-year *explicit* service period. Because the award requires the employees to provide future service, compensation cost is recognized over the two-year requisite service period. Therefore, there is no immediate recognition at the grant date (also the service inception date) of any portion of the cost associated with the award.

4.057 Conversely, for employee or nonemployee awards that are fully vested at the date of grant (assuming that the grant date is also the service inception date), the total compensation cost of the award would be recognized at the date of grant because there is no future service requirement. Furthermore, the total compensation cost of an award would be recognized at the date of grant for an award that is immediately vested even if the award is not immediately exercisable (although there may be a valuation consequence for the post-vesting restriction on exercisability as further explained in Paragraphs 2.138a and 2.139b). ASC paragraph 718-10-55-68

4.058 Certain awards have features that shorten an employee's requisite service period to a period less than the service period explicitly stated in the award. In such cases, compensation cost under the award should be recognized over the minimum period for which the employee is required to provide service to vest in the award. For example, for an award that vests after five years or when an employee retires, compensation cost for employees becoming eligible for retirement within five years of the grant date would be recognized over the period from grant date to the date at which the employee is eligible for retirement, rather than over five years. Compensation cost would be recognized immediately on the grant date for employees that are eligible for retirement at the grant date even if the employees have indicated they have no current intention to retire.

Nonemployee awards also can have a shorter vesting period than stated in the terms of the award, depending on the circumstances and related attribution – see Paragraph 4.053.

4.058a When retirement eligibility clauses are included in awards, the facts and circumstances of the clauses are considered to determine its impact on the attribution for the award. Many retirement eligibility clauses include a requirement for a notice period to be provided to the company, prior to a planned retirement. For example, a retirement eligible employee may be required to provide a notice period (e.g., six months) and continue to provide services to the company during that six-month period. In these circumstances, the clause requiring a notice period must first be assessed as to whether it is nonsubstantive, as discussed in Paragraph 4.062. To the extent it is determined to be nonsubstantive, the clause requiring a notice period would be ignored in determining the attribution period for the award (or essentially the period in which to take the compensation expense).

4.058b When a company grants awards to an employee who is otherwise retirement eligible at the grant date but has not yet given his or her notice and the notice period is deemed to be substantive, we believe the company would have a policy election on how to determine the attribution period. One alternative would be to determine the attribution period as the length of the notice period, with the compensation expense recognized over this period. Another alternative would be for a company to continuously update its estimate of the attribution period until the employee provides the required notice. This alternative would require continuous monitoring of the awards on an employee-by-employee basis and would likely lead to more complex accounting. This is because a company would be required to monitor and update its estimate of the attribution period for each award for each employee at the end of each reporting period.

4.058c When such a clause requiring a notice period is included in an award and the employee is not yet retirement eligible at the grant date, the clause is still considered in determining the attribution period. When an employee is eligible to retire before the length of time for the stated or implied service period of the award (e.g., the employee becomes retirement eligible in 18 months and the stated or implied service period of the awards is 24 months), the company considers whether the employee would be eligible to give notice of his or her retirement prior to his or her retirement eligibility date. Depending on the terms of the plan and the related service period, the ability to give notice may or may not affect the attribution period of the award.

Example 4.10: Award Granted to a Retirement-Eligible Employee Does Not Include a Substantive Future Service Condition at the Grant Date – Part I

On January 1, 20X6, ABC Corp. grants an award of share options to its longer-term employees with an exercise price equal to ABC's share price on January 1, 20X6. All necessary approvals for the award have been obtained on January 1, 20X6. The awards cliff vest after four years of service. However, ABC's plan states that awards will immediately vest when an employee retires.

ABC uses a *points* system whereby employees are eligible to retire when the combination of the employee's age and years of service equals 75. ABC determines that at the date of grant all of the recipients are retirement-eligible (i.e., all of the recipients have 75 or more points at the date of grant).

Because all of the recipients are retirement-eligible at the date of grant and because unvested awards vest immediately on retirement, there is no substantive service period for the award. As a result, the grant-date fair value of the awards would be immediately recognized as compensation cost at the date of grant. ASC paragraphs 718-10-55-87 and 55-88

Example 4.10a: Award Granted to a Retirement-Eligible Employee Does Not Include a Substantive Future Service Condition at the Grant Date – Part II

Assume the same facts as in Example 4.10 except that employees are required to provide six months' notice prior to retiring. Because all of the recipients at the date of grant are required to provide six months of service before they are retirement-eligible, there is a six month substantive service period. As a result, the grant-date fair value of the awards should be recognized as compensation cost over the six-month period beginning on the date of grant. ASC paragraphs 718-10-55-87 and 55-88

Q&A 4.7: Grant When Continued Employment Is Not Required but Exercisability Is Deferred

Q. An entity's board of directors grants fully vested share options to certain key employees. The share options become exercisable in three years even if the entity no longer employs the individuals. Because the share options are fully vested, the employee is not required to provide future service even though there is a three-year exercisability restriction. Does the delayed exercisability provision in the award give rise to a requisite service period over which the compensation cost is recognized?

A. No. The entity should recognize the total compensation cost of the award at the date of grant because the share options are fully vested and nonforfeitable at that time. Although the exercise of the share options is not permitted for three years, it is contingent only on the passage of time and not on future performance or employment conditions. The delay in the exercisability of the awards would affect the grant-date fair value but would not affect the immediate recognition of the total compensation cost of the award. See Paragraph 2.075 for additional guidance on the valuation effect.

Q&A 4.8: Grant When Continued Employment Is Required

Q. An entity's board of directors grants fully vested share options to certain key employees. The share options become exercisable in three years. However, if the employees depart from employment with the entity before the awards are exercisable, they forfeit the awards. Does the delayed exercisability give rise to a requisite service period over which the compensation cost is recognized?

A. In this situation, the delayed exercisability of the award constitutes a service condition. Because the employees forfeit the awards if they terminate their employee relationship with the company before the end of the three-year period, the award is the grant of share options with a three-year service period. As such, the compensation cost would be recognized over the three-year requisite service period.

Q&A 4.9: Grant of a Performance-Based Award to Retirement Eligible Employees**Background**

On January 1, 20X6, ABC Corp. made a grant of performance-based nonvested shares to a group of employees. Included within the employee group are employees who are retirement-eligible at the grant date.

The performance conditions stated that the awards vest based on achieving the following EPS targets for the year ending December 31, 20X6:

- If EPS is less than \$1 per share, 0 shares vest
- If EPS is at least \$1 but less than \$1.50 per share, 500 shares vest
- If EPS is greater than or equal to \$1.50 per share, 1,000 shares vest

ABC's plan provides that on retirement, employees keep their unvested awards and those awards vest if the performance targets are achieved.

At the grant date, ABC estimates a 10% likelihood that EPS will be less than \$1 per share, a 60% likelihood that EPS will be greater than or equal to \$1 and less than \$1.50 per share, and a 30% likelihood that EPS will be greater than or equal to \$1.50 per share. Based on these estimated outcomes, the weighted-average number of shares expected to vest is 600.

For the year ended December 31, 20X6, ABC's EPS was \$1.40. As a consequence, the number of shares earned is 500.

Q. How should compensation cost for the performance-based nonvested shares be measured and recognized for retirement-eligible employees?

A. ABC would consider that vesting in some portion of the award is probable given that there is a 90% probability of at least 500 shares vesting and a 30% probability of 1,000 shares vesting. Accordingly, ABC would initially record compensation cost for 500 shares. Because the employees are retirement eligible, the compensation cost would be recorded in full on the grant date. If there were a change in estimate in the number of shares expected to be earned, a true up adjustment would be recorded as compensation cost in the period the change in estimate is identified.

SERVICE CONDITION IN A GRANT OF DEEP OUT-OF-THE-MONEY, FULLY VESTED SHARE OPTIONS

4.059 The grant of a fully vested employee or nonemployee award typically results in immediate recognition of the related compensation expense if the fully vested condition is substantive. One potential exception to the immediate recognition of compensation cost for fully vested employee share options would be when an entity grants deep out-of-the-money share options. Such a grant is equivalent to the grant of an award with both a market condition and a service condition (see Paragraph 4.068 for a discussion of market conditions). The presumption that the award is for past services would be overcome in this situation because the employee would need to provide future service (i.e., continuing employment is necessary) before the share price is expected to increase to a level when the share option has intrinsic value. However, there is no bright-line that indicates when an out-of-the-money grant constitutes a deep out-of-the-money grant. Therefore, all facts and circumstances surrounding the grant should be carefully evaluated. Factors to consider are: (a) the amount by which the award is out-of-the-money on the grant date, (b) the expected volatility of the underlying stock (if volatility is higher, an award would need to be further out-of-the-money to be considered to be deep-out-of-the-money), and (c) the period of time the employees are expected to remain employed. The assumptions used in determining the employee's requisite service period should be consistent with assumptions used in estimating the fair value of the awards. ASC paragraph 718-10-55-67

Q&A 4.10: Grant of Fully Vested, Deep Out-of-the-Money Share Options

Q. On July 1, 20X5, ABC Corp. grants fully vested share options to certain members of management. The exercise price of the share options is \$30. At the date of grant, the market price of ABC's shares is \$3 per share. Should compensation cost be recognized immediately or should a requisite service period be determined?

A. Although the award is fully vested at the grant date, compensation cost would be recognized over future periods because the exercise price of the share option is significantly above the current market price of ABC's shares. The share options are deemed to contain a substantive market condition because the market price of ABC's shares needs to increase substantially before the share options have intrinsic value. A requisite service period would be derived and compensation cost would be recognized over the derived requisite service period. Because this award would be considered to contain a market condition, the existence of the market condition would be reflected in

the award's grant-date fair value. See Paragraph 4.068 for a discussion of market conditions.

SERVICE CONDITION WITH EMPLOYEE GRANTS CONTAINING A NONCOMPETE PROVISION

4.060 Some employee awards may contain noncompete provisions that can require an employee to forfeit share options or return shares under certain conditions after they have been vested if the employee leaves the entity. Authoritative guidance indicates that the existence of a noncompete provision may represent an in-substance service condition. Determining whether a noncompete provision represents an in-substance service condition is a matter of judgment based on the facts and circumstances of the award. ASC Topic 718 provides factors an entity should consider in determining that a noncompete provision creates a substantive vesting condition. The evaluation of these factors should be made at the individual grantee level, not to groups of employees that may have similar demographic characteristics. The factors provided in ASC Topic 718 are:

- Whether the provision is legally enforceable;
- Whether the entity intends to enforce the provision and its past practice of enforcement;
- Whether the employee's rights to the instruments, such as the right to sell the instruments, are affected by the noncompete provision;
- The existence or absence of an explicit service condition in the award;
- The fair value of the award in relation to the employee's annual compensation; and
- The severity of the provision in limiting the employee's ability to work in the entity's industry.

Importantly, evaluating whether a noncompete agreement creates a substantive service period extends beyond determining that the noncompete agreement is, in and of itself, a substantive agreement. While it is a necessary condition that the noncompete agreement be substantive, that is not a sufficient condition to conclude that the noncompete agreement creates a requisite service period. Rather, based on the facts and circumstances associated with the arrangement, the company can demonstrate that the *individual* employee is compelled by the agreement to provide future service to the company to receive the benefits of the award.

4.061 Based on the terms of the noncompete provision, one or more of the above factors may be more important than the others in determining an in-substance service condition exists. Generally, if the noncompete provision is not legally enforceable, if the entity does not have the intent to enforce the provision, or if it has a past practice of not enforcing such provisions, the requisite service period would not be affected by the noncompete provision. The FASB and SEC staffs have indicated that these factors should be applied in only the limited circumstance described in ASC Topic 718 (i.e., noncompete

provisions) and should not be generalized to other situations. We believe that it would be extremely rare for a noncompete provision to create a substantive service condition. Accordingly, in most cases, noncompete provisions would be treated like a clawback provision (see Paragraph 2.086). Since the effectiveness of this guidance in 2006, we are not aware of circumstances in which an assertion that a noncompete provision extended the requisite service period of an award was sustained. ASC paragraph 718-20-55-91

NONSUBSTANTIVE SERVICE PERIOD

4.062 ASC Topic 718 states that for awards with only a service condition, the employee's requisite service period is presumed to be the vesting period, and the nonemployee vesting period is the stated vesting period in the terms of the award. However, all relevant facts and circumstances should be considered in determining the employee's requisite service period or the nonemployee's vesting period. As discussed in Paragraph 4.058, some companies have provisions or existing practice where an employee can retain unvested awards on retirement. In some cases, unvested awards are immediately vested on retirement while in other cases, the *vesting* period continues after retirement. In these situations, the facts and circumstances of the stated vesting period are assessed further to determine if the nature of the services being provided after retirement are substantive. Factors to consider in evaluating whether such services are substantive include, but are not limited to:

- Whether the retired employee has specific duties during the vesting period after retirement, for example, a requirement to provide services for a specific amount of time each week;
- Whether there are specific deliverables under a service agreement;
- Whether the compensation being received during the vesting period after retirement is reasonable in relation to the services provided;
- Whether the performance of the retired employee during the vesting period after retirement is subject to supervision;
- Whether the length of the service period after retirement exceeds a normal length of time to provide the required services (e.g., transitional services).

Arrangements that require the retired employee to be available for a certain minimum number of hours per week or month, e.g., if the entity requires assistance, or for the retired employee to aid the transition for that retired employee's replacement, normally are not substantive services. In the case where the stated vesting period is deemed to be nonsubstantive, the employee requisite service period would be from the service inception date (which is usually the grant date) to the first date when the employee is eligible to retire while retaining the award (see Paragraph 4.058). ASC paragraphs 718-10-55-67 and 55-68, 55-87

4.063 Companies whose plans include such provisions will need to determine the appropriate employee requisite service period for each grantee. Those who meet the retirement requirements at the date of grant have no employee requisite service period

because those employees can retire immediately after receiving the grant and still retain the award. In substance, for retirement-eligible employees, the award amounts to the grant of a fully vested award. Other employees, however, may not be retirement-eligible at the time of the grant but will become retirement eligible before the end of the stated vesting period (e.g., an employee who will become retirement-eligible in two years who receives a grant with a four-year vesting period). As a consequence, companies with such provisions may find that there are many different employee requisite service periods for the grantees included in a broad-based grant.

Example 4.11: Effect of Nonsubstantive Service on an Employee Requisite Service Period

On January 1, 20X6, ABC Corp. grants 250,000 share options to four of its employees. The share options vest after four years of service. However, ABC's practice is that employees who reach the *normal* retirement age and subsequently retire are entitled to keep all unvested awards (i.e., unvested awards become fully vested at the time of retirement). Normal retirement age for ABC's employees, for purposes of retaining share option awards, is 62. At the date of the grant, Employee 1 was 64 years old, Employee 2 was 45 years old, Employee 3 was 60 years old, and Employee 4 was 61 years old.

The requisite service period for the grant for each of the four employees would be:

| | |
|------------|---|
| Employee 1 | 0 (i.e., the award is treated as a grant of fully vested share options with compensation cost immediately recognized) |
| Employee 2 | 4 years |
| Employee 3 | less than 2 years (service period would be from the grant date to the employee's 62nd birth date) |
| Employee 4 | less than 1 year (service period would be from the grant date to the employee's 62nd birth date) |

Example 4.11a: Share Option Awards Granted to Retirement-Eligible Employees with a Service and Performance Condition that Can Be Achieved after Retirement

Note: This example does not address the accounting for grantees that are not or will not become retirement eligible during the employee's requisite service period.

In January 20X9, ABC Company granted nonvested shares to members of executive management. The nonvested shares vest at the end of a three-year service period, and contain performance conditions as described below.

- For a three-year performance period, there is a separate performance target for each year that is specified at the grant date. The performance targets are weighted at 75% of a Return on Invested Capital (ROIC) target and 25% of an Operating Ratio (OR) target.

- Each target has a range of "threshold" to "maximum", which is the basis for calculating the earned percentage each year between 50% and 200% (or 0% if the threshold levels of the ROIC target or the OR target are not met).
- At the end of the three-year performance period, the three separately calculated earned percentages are averaged, and that average is multiplied by the target number of shares to arrive at the earned number of shares.
- For an employee who is (or becomes) retirement-eligible during the three-year performance period, each month in which he/she remains employed with ABC Company during the three-year performance period entitles him/her to 1/36 of the total earned shares. For example, if an employee retires in July 20X9, then he/she would be entitled to 7/36 of the total earned shares as determined at the end of the three-year period. If the total earned shares as determined were 300 shares (Earned percentage Year 1 - 0%; Year 2 - 200%; Year 3 - 100%; Average of three years = 100% and 300 shares granted "at target"), then the employee would receive 58 shares ($300 \text{ shares} \times 7/36 \times 100\%$).

In addition, the above scenario assumes that an employee who is retirement-eligible at the grant date is not vested in this award at the date of grant; the provision of an additional month of service entitles the retirement-eligible employee to an additional 1/36 of the earned shares. In this example a substantive service condition exists in addition to the performance condition. Also, because each month of service results in earned shares that do not require additional service, it causes the awards to have a graded service period rather than a full three-year service period for all shares. Even though the nonvested shares have, in effect, a graded-vesting schedule, the attribution period is three years, which is based on the explicit service period over which the awards will be earned. With both a service condition and a performance condition, however, the policy election to recognize the compensation cost on a straight-line basis is not available to ABC, as discussed further in Paragraphs 2.088 and 4.080. Therefore, compensation cost for the nonvested shares will be recognized at the grant date on a tranche-by-tranche basis for each of the 36 monthly tranches for all retirement-eligible employees. This results in the recognition of a higher percentage of the compensation cost in the first month versus the last month. ABC should recognize compensation cost if it is probable that the performance condition will be achieved.

In the above scenario, if we assume that an employee is not retirement-eligible at the grant date and is not vested in this award at the date of grant but will become retirement-eligible during the performance period, in determining the graded-vesting schedule, the tranches would take into consideration the employee's retirement eligibility date. Each additional month of service would represent a separate tranche. For example, awards granted to an employee who is not retirement-eligible on January 1, 20X9 (the grant date) but who will become retirement-eligible on July 30, 20X9, will have a total of 30 tranches in the graded-vesting schedule with the first tranche equal to 7/36 of the total earned shares and 29 monthly tranches for each additional month of service over the remaining performance period. Accordingly, compensation cost for the nonvested shares for this employee will be recognized on a tranche-by-tranche basis for each of the 30 tranches.

If the retirement eligibility varies, a separate employee-by-employee analysis would be required to determine the number of tranches in the graded-vesting schedule.

IMPLICIT SERVICE CONDITION FROM ESCROWED SHARE ARRANGEMENTS

4.063a Implicit service conditions can result when the terms of the award require additional service in order to retain an award, even for awards that are already vested. Arrangements entered into for vested shares, e.g., when companies provide for a buyback program in which vested and exercised share options can be bought back by the company at the original exercise price if the employee ceases to be employed over a set period of time, create an implicit service condition. The implicit service condition exists as the shares are essentially escrowed until that service condition has been met by the passage of time.

Q&A 4.10a: Buyback Provision Amendment Creates Implicit Service Condition

Background

A few months before entering into a merger, employee founders of a private entity agreed to modify their employee agreements to include buyback provisions, which would give the private entity (and post-merger, the acquiring entity) the right to repurchase their outstanding common shares (buyback shares) for \$0.001 per share (which is significantly below fair value) over four years under certain conditions. At the time of the modification, each employee founder owned 1,000 common shares, which were fully vested. On consummation of the merger, the acquirer would replace the private company common shares with its common shares, but the buyback provision would be retained in the terms of the new shares.

On the first four anniversaries of the modification, the right to repurchase 250 of the buyback shares would terminate so that after four years, the right to repurchase the employee founders' buyback shares would terminate completely. Under the buyback provisions, if the entity were to terminate an employee founder for cause or if the employee founder were to leave without good reason during the four years, the entity may buy back the shares not previously released for \$0.001 per share.

Q. Does the employee agreement that is amended to add a buyback provision, which allows an entity to repurchase shares of an employee's common shares at less than fair value, create an implicit service condition?

A. Yes. Although the common shares were fully vested before the modification of the employee agreements, the buyback provisions created a new implicit service condition whereby the common shares would be akin to share-based payment awards that vest ratably over a four-year term on the condition that the employee founders continued to be employed by the entity during that term.

Additionally, the buyback provisions essentially function as a forfeiture/vesting provision in the form of a repurchase feature, because they permit the entity to repurchase the shares for \$0.001 (i.e., significantly below fair value), if the employee founders were to leave without good reason or are terminated for cause. This would prescribe treating the common shares as the grant of a share option with a four-year service period, not the grant of a fully vested share, as described in Paragraph 3.038.

Because the awards have a service condition for which the employees have not rendered all of the service as of the acquisition date, the entity would account for the fair value of the replacement awards between the precombination and postcombination period, following the attribution guidance in Paragraphs 11.030 through 11.032 of KPMG Handbook, *Business Combinations*.

PERFORMANCE CONDITION

4.064 ASC Section 718-10-20 defines a performance condition as:

A condition affecting the vesting, exercisability, exercise price, or other pertinent factors used in determining the fair value of an award that relates to both (a) rendering service or delivering goods for a specified (either explicitly or implicitly) period of time, and (b) achieving a specified performance target that is defined solely by reference to the grantor's own operations (or activities) or by reference to the grantee's performance related to the grantor's own operations (or activities). Attaining a specified growth rate in return on assets, obtaining regulatory approval to market a specified product, selling shares in an initial public offering or other financing event, and a change in control are examples of performance conditions [for purposes of ASC Topic 718]. A performance target also may be defined by reference to the same performance measure of another entity or group of entities. For example, attaining a growth rate in earnings per share that exceeds the average growth rate in earnings per share of other entities in the same industry is a performance condition [for purposes of ASC Topic 718]. A performance target might pertain to the performance of the entity as a whole or to some part of the entity, such as a division, or to the performance of the grantee if such performance is in accordance with the terms of the award and solely relates to the grantor's own operations (or activities). ASC Section 718-10-20

4.065 A performance condition is a requirement for the grantee or entity to achieve a specific operating or financial goal before the grantee can earn the award (e.g., grantees earn an award if the entity's sales increase by 50% over the next three years). A performance condition normally includes a service condition, either explicitly or implicitly. However, there are situations in which the absence of a substantive future service condition will still result in the award being deemed to contain a performance condition. Paragraph 4.100 provides additional discussion of these circumstances.

Q&A 4.11: Vesting Based on EPS Growth – Part I

Q. ABC Corp. grants 100,000 share options to employees on January 1, 20X6. The awards will vest in three years if, during the three-year period, the growth in the company's EPS (computed based on net income) exceeds the average growth in EPS (based on net income) of the company's top five competitors. Does the award contain a performance condition?

A. Yes. The award contains a performance condition that references the same performance measure (growth in EPS) for the company compared to a group of peer companies.

Q&A 4.12: Vesting Based on EPS Growth – Part II

Q. ABC Corp. grants 100,000 share options to employees on January 1, 20X6. The awards will vest in three years if, during the three-year period, the growth in the company's EPS (computed based on income from continuing operations) exceeds the average growth in EPS (based on net income) of the company's top five competitors. Does the award contain a performance condition?

A. No. In this situation, the award does not contain a reference to the same performance measure because the company's EPS growth is calculated based on income from continuing operations while the competitors' EPS growth is calculated based on net income. The award would contain an *other* condition (one that is not a service, performance, or market condition), and as a result, the award would be classified as a liability (see Paragraph 3.008).

Q&A 4.13: Vesting Based on EPS Growth – Part III

Q. ABC Corp. grants 100,000 share options to employees on January 1, 20X6. The awards will vest in three years if, during that three-year period, the growth in the company's EPS (computed based on net income) exceeds the growth in gross domestic product (GDP). Does the award contain a performance condition?

A. No. The award does not contain the same performance condition for the company (EPS) as for the reference measure (GDP). As a consequence, the award would contain an *other* condition (one that is not a service, performance, or market condition). Therefore, the award would be classified as a liability (see Paragraph 3.008).

Q&A 4.13b: Vesting is Conditioned Upon Occurrence of an Exit Event at a Significant Stakeholder Level

A private equity firm is a significant shareholder of Company A and has issued share options to employees of Company A as part of their overall compensation. The underlying for the share options are shares of the holding company that the private equity investor established when it purchased its controlling interest in Company A. In addition to a service condition, vesting of the share options is conditioned upon the private equity firm having a liquidity event, which is defined in the agreements as either a) a sale of the private equity firm's shares in the holding company to a third party such that the private equity firm loses control of Company A; b) a sale of additional shares of Company A to a third party with sufficient dilution that causes the holding company to lose control of Company A; or c) the sale of shares of either the holding company or Company A to the public in an IPO (without regard to whether this causes the holding company to lose control of Company A).

Q. Should the enterprise, which grants an employee share option whose vesting is conditioned upon occurrence of an exit event at a significant stakeholder level, account for that condition as a *performance condition* for the purposes of recognizing compensation cost?

A. Yes, we believe it is reasonable to conclude that the award has a performance condition as that term is defined in ASC Topic 718. The typical business model of private equity firms is to purchase investments in companies, restructure their operations and exit the investment in 2-5 years. They also typically create compensation incentives for management related to the private equity firm's exit from its investment in the company. These typically take the form of awards contingent on the exit of the investment (either by sale to a third party or to the public in an IPO) as well as awards with realized return on investment targets that meet the definition of market conditions.

Although the performance condition is defined in this instance to include certain financing events occurring higher up in the legal organization structure (at the holding company level) and not necessarily a direct financing event of Company A in which the employees work, it can be considered as an *other financing event*. In this instance, the holding company's sole substantive asset is its investment in Company A. Given that fact and the typical business model of private equity firms to exit investments in 2-5 years, the defined performance conditions are essentially inseparable from the operations of Company A, even though some of them are events that would occur at a higher level in the legal organization structure.

In addition, ASC paragraph 718-10-15-4 further supports this approach, as it states that:

...share-based payments awarded to a grantee of the reporting entity by a related party or other holder of an economic interest in the entity as compensation for services provided to the entity are share-based payment transactions to be accounted for under this topic [ASC 718][...] The substance of such a transaction is that the economic interest holder

makes a capital contribution to the reporting entity, and that entity makes a share-based payment to the grantee in exchange for services rendered or goods received.

4.066 The requisite service period for employee awards with a performance condition may be either stated explicitly or it may be implicit in the award. For example, an award that vests if an entity's market share exceeds 20% after three years is a performance condition with an explicit service period of three years. An award that vests when an entity's market share exceeds 20% has an implicit service period because there is no explicitly stated time period over which the performance condition is required to be met. The implicit service period associated with a performance condition should be based on an entity's best estimate of the period over which the performance condition would be met. ASC paragraphs 718-10-55-69 and 55-70 Similarly, for nonemployee awards with a performance condition, the vesting period may be either stated explicitly or it may be implicit in the award. Nonemployee awards granted in exchange for goods or services may involve an immediate or short-duration exchange of the awards for goods or services, or, may involve an exchange that spans multiple reporting periods. In addition, the quantity and vesting terms of the awards to be granted may or may not be known when the arrangement is established due to specific conditions, such as performance conditions that are dictated by the terms of the agreement. As a result, judgment may be required to determine the vesting period for nonemployee awards, and therefore the period(s) in which to recognize compensation cost. ASC paragraph 718-10-25-2B

4.067 As noted in Paragraph 4.065, a performance condition normally includes a service condition. For a grant of an award with a *performance* condition wherein the service period is nonsubstantive (e.g., employee is eligible to retire at the date of grant), the definition of a performance condition in ASC Section 718-10-20 is still met because there is, effectively, a one-day employee requisite service period. Compensation cost would be recognized at the grant date if the entity concludes that it is probable that the performance condition will be attained.

Q&A 4.14: Interaction of Nonsubstantive Service Period with a Performance Condition

Q. ABC Corp. grants 100,000 share options to employees on January 1, 20X6. The awards will vest in three years if, during that three-year period, the growth in the company's EPS (computed based on net income) exceeds the growth in EPS (computed based on net income) for peer group companies. At the date of grant, employees receiving 40,000 share options are retirement eligible under ABC's retirement policies. These employees can retire while still retaining their rights to the award, although the shares will not be delivered to them until the end of the three-year period and only if the performance condition is met. Additionally, for those employees who will become retirement-eligible before the end of the three-year period, the award contains a requisite service period (from the grant date to the date when an individual employee becomes retirement eligible). At the grant date, the best estimate is that it is probable that the company's EPS growth will exceed the growth in EPS for peer companies.

A. There are three different groups of employees and the accounting differs for each group. For employees who are retirement-eligible at the grant date, the entire grant-date fair value will be immediately recognized as compensation cost. For those employees who will become retirement eligible before the three-year period is complete, the grant-date fair value will be recognized over their employee requisite service period (from grant date to the date each individual employee becomes retirement-eligible). For employees that will not be retirement eligible, the grant date fair value will be recognized as compensation cost over the three-year employee requisite service period.

4.067a It may not always be clear whether a condition is a performance condition, for which equity-classification may be appropriate, or an other condition, which requires liability classification. See discussion on other conditions in Section 3, beginning at Paragraph 3.006. Q&A 3.5a discusses certain ESG targets, as do Sections 11.2 and 11.3 of KPMG Handbook, Climate risk in the financial statements.

MARKET CONDITION

4.068 ASC Section 718-10-20 defines a market condition as:

A condition affecting the exercise price, exercisability, or other pertinent factors used in determining the fair value of an award under a share-based payment arrangement that relates to the achievement of (a) a specified price of the issuer's shares or a specified amount of intrinsic value indexed solely to the issuer's shares, or (b) a specified price of the issuer's shares in terms of a similar (or index of similar) equity security (securities). The term similar as used in this definition refers to an equity security of another entity that has the same type of residual rights. For example, common stock of one entity generally would be similar to the common stock of another entity for this purpose. ASC Section 718-10-20

4.069 A market condition relates to achieving a target share price or specified amount of intrinsic value or a specified growth in the entity's share price compared to a similar equity security or index of equity securities. For example, an award that becomes exercisable if the closing price of the entity's shares is above \$25 per share for 30 consecutive days is a market condition. Likewise, an award that is exercisable if the entity's share price outperforms the S&P 500 index for a specified period of time is a market condition.

4.070 As discussed in Paragraph 2.081, the existence of a market condition affects the grant-date fair value of an award. While the term *exercisability* is used when referring to an award with a market condition, it has the same meaning when accounting for a share-based payment award as the term *vesting*, which is used for awards with a service or performance condition that is used to determine the attribution period. ASC paragraphs 718-10-30-12 and 30-14, 30-27, and 55-60

4.071 The requisite service period for an employee award with a market condition may be explicitly stated or it may need to be *derived* from the valuation technique used to estimate grant-date fair value of the award. An award that is exercisable if the share price outperforms the S&P 500 index over the next three years has an explicit service period of three years. However, for an award that becomes exercisable once the share price reaches \$20 per share, the employee requisite service period is derived from the valuation model. The *derived service period* is based on the duration of the most frequent path (median of the distribution) of the path-dependent option pricing model on which the market condition is satisfied (see Paragraph 2.082). ASC paragraph 718-10-55-71. Similarly, for nonemployee awards with a market condition, the nonemployee vesting period may be either stated explicitly or derived from the valuation technique used to estimate the grant-date fair value of the award.

4.072 As described in the previous paragraph, the service or vesting period is derived from the valuation model used to estimate the grant-date fair value of the employee or nonemployee award. The grant-date fair value is estimated using a risk-free interest rate assumption. However, because the derived service or vesting period is a measurement of *when* a market condition will be reached, it is related to timing rather than valuation. Stock prices increase at a risk-adjusted rather than a risk-free rate. ASC paragraph 718-10-55-71 states that “A derived service period is inferred from the application of certain valuation techniques used to estimate fair value.” While ASC Topic 718 requires that the same valuation *technique* be used to determine the derived service or vesting period as is used to estimate the award’s grant-date fair value, it does not require that the same interest-rate assumption be used for both. Historically entities have used either an equity rate of return or a risk-free rate when determining the derived service period of an award. Use of the equity rate of return assumption would require the reporting entity to re-run the valuation model (e.g., a simulation), whereas determining a derived service or vesting period using a risk-free rate would not, because the derived service or vesting period would be inferred from the same valuation model used to estimate the fair value of the award. We believe that the use of an equity rate of return is preferable, however entities granting awards requiring the determination of a derived service period should apply a consistent policy.

4.072a As discussed in Paragraph 4.124, liability-classified awards are remeasured at each financial reporting date until settlement of the award. When the service period is known, the requisite service period is generally updated each reporting date when the award is remeasured. However, when the service period is derived, for example, for liability-classified awards with market conditions, we believe there are two acceptable approaches for updating the requisite service period. An entity may either (1) continue to use the derived service period determined at the grant date and not update it as part of the remeasurement of the award, or (2) update the derived service period each reporting date as part of the remeasurement of the award. An entity must make an accounting policy election and apply it consistently.

4.073 If the exercisability of an equity-classified award depends on the achievement of a market condition, recognized compensation cost is not reversed if an equity-classified award does not become exercisable because the market condition is not achieved as long

as the grantee delivers the promised goods or renders the services. For an equity-classified award with a market condition, previously recognized compensation cost would be reversed only if the grantee did not deliver the promised goods or render the services. However, if the market condition is satisfied before the end of the employee's requisite service period or nonemployee's vesting period, the compensation cost is not reversed. ASC paragraph 718-10-55-61

4.073a If the exercisability of a liability-classified award depends on the achievement of a market condition and the award does not become exercisable because the market condition is not achieved, the fair value on the settlement date will be zero. As a result, any previously recognized compensation cost would be reversed, to bring the fair value of the award recognized as compensation cost to zero. ASC paragraph 718-10-55-9

Q&A 4.15: Vesting Based on the Share Price Outperforming the S&P 500 Index

Q. ABC Corp. grants a share option containing a condition that the company's share price must outperform a broad-based measure or index, such as the S&P 500 Index, in order for the share option to become exercisable. Is this considered a *market condition*?

A. Yes, the award contains a market condition. A market condition is defined as a condition affecting the exercise price or exercisability of an award based on the achievement of (a) a specified price of the issuer's shares or a specified amount of intrinsic value indexed solely to the issuer's shares, or (b) a specified price of the issuer's shares in terms of a similar (or indexed to a similar) equity security (securities).

Therefore, the performance of ABC's share price in relation to a broad market index, including the S&P 500 Index, or in relation to an index of peer companies, would meet the definition of a market condition.

SUMMARY OF CONDITIONS

4.074 Example 4.12 summarizes the types of conditions under ASC Topic 718.

Example 4.12: Conditions and Related Employee Service Period of an Award

| Condition | Examples | Employee Requisite Service Period* |
|--|---|---|
| Service A requirement to achieve a specific duration of employment | An award that vests after four years of service | Explicit service period of four years |

Performance

A requirement to achieve an operating or financial target

An award vests at the end of three years if the company's average EPS for the next three years is \$4

Explicit service period of three years

An award vests when cumulative sales of Product A reach \$100 million

Implicit service period estimated based on company budgets and projections, etc.

Market

A requirement to achieve a specific measure of the company's share price or by comparison of the company's share price performance to an index of equity securities

An award becomes exercisable when the stock price is above \$80 per share for 20 consecutive days

Derived service period from the valuation technique used to value the award

An award becomes exercisable if the company's share price outperforms the share price of its peer group during the next two years

Explicit service period of two years

An award becomes exercisable if total shareholder return (TSR) outperforms a peer group of companies during the next two years

Explicit service period of two years

An award becomes exercisable based on an investor achieving a specified rate of return (e.g., internal rate of return)

Derived service period from the valuation technique used to value the award

*Note that for nonemployee awards, there is a vesting period that also can be explicit or implicitly derived. The explicit and implicit service periods noted in this table would result in similar explicit and implicit vesting periods for nonemployee awards.

MULTIPLE CONDITIONS

4.075 An award can contain more than one condition, e.g., a service and a market condition. Because more than one condition can apply to an award, there can be more than one explicit, implicit, or derived service or vesting period. However, an award can have only one employee requisite service period or one nonemployee vesting period for attribution purposes. If an award contains two or more service or vesting periods, the employee requisite service period or nonemployee vesting period depends on whether the conditions are in an *or* an *and* relationship. The employee requisite service period or nonemployee vesting period is the shorter of the periods in an *or* relationship (e.g., the award vests on satisfaction of four years of service or when the cumulative sales of Product X exceed \$10 million). The employee requisite service period or nonemployee vesting period is the longer of the periods in an *and* relationship (e.g., an award is exercisable when cumulative sales of Product X exceed \$10 million and the entity's stock price exceeds \$20 per share for 20 consecutive trading days). In some cases the service period may be deemed nonsubstantive (and compensation would be recorded immediately – see Paragraph 4.062). ASC paragraphs 718-10-35-5, 55-72 and 55-73

4.076 The following flowchart provides guidance on determining the initial employee requisite service period for an award. It also can be analogized to the initial nonemployee vesting period for an award, when the nonemployee award is granted for services to be provided.

Determining the Requisite Service Period of an Employee Award*

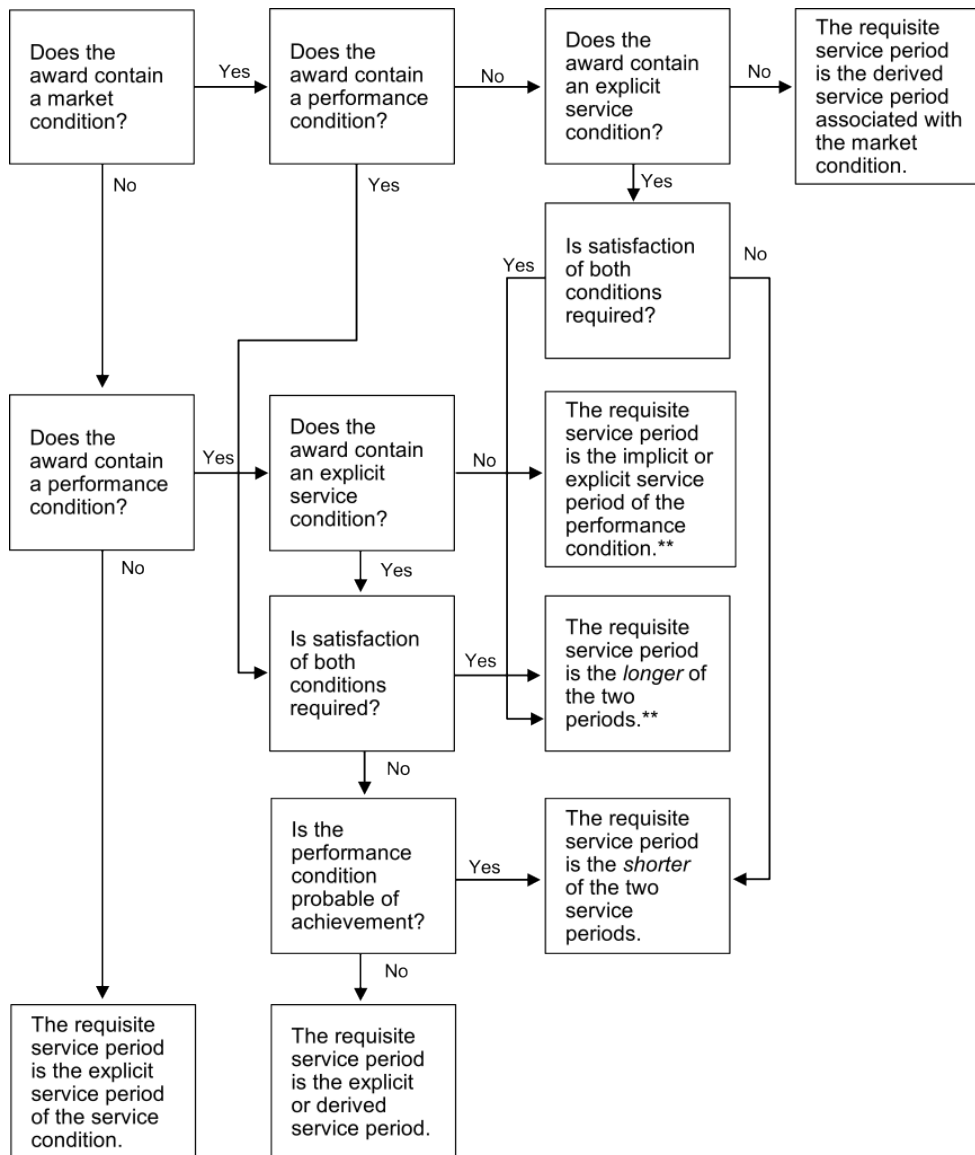

* An award containing a service condition, a performance condition, and a market condition would be evaluated in a manner similar to an award with a service or performance condition and a market condition.

** If the award contains a performance condition that is not probable of achievement, no compensation cost would be recognized until the performance condition becomes probable of achievement.

ATTRIBUTION PERIOD FOR EMPLOYEE AWARDS WITH A SERVICE CONDITION

4.077 The employee's requisite service period of an award is the period over which the employee's service is rendered in exchange for an award. As such, the grant-date fair value of an equity-classified award is recognized over the employee's requisite service period (the attribution period). The employee's requisite service period for awards should

be consistent with the assumptions used in estimating the grant-date fair value of the award. ASC paragraph 718-10-35-5 and 718-10-55-67

Cliff-Vesting Awards

4.078 For awards that contain only a service condition, the employee requisite service period is the explicit service period of the award and would be the period over which compensation cost is recognized. Awards under which 100% of the awards vest on completion of the explicit service period are referred to as *cliff-vesting* awards. For cliff-vesting awards, the compensation cost is recognized ratably over the employee requisite service period.

Example 4.13: Recognition of Compensation Cost for a Cliff-Vesting Award

Background

| | | | | |
|---|---|---|-----|-------------|
| Share options granted to CEO on January 1, 20X5 | 20,000 | | | |
| Vesting schedule | 100% at December 31, 20X8 (cliff vesting) | | | |
| Share option grant-date fair value | \$5 per share option | | | |
| Requisite service period (1/1/X5 – 12/31/X8) | 4 years | | | |
| Total compensation cost of award | \$20,000 | × | \$5 | = \$100,000 |
| Compensation cost recognized each year | \$100,000 | / | 4 | = \$25,000 |

Compensation cost recognized

| | Current Year | Cumulative |
|------|--------------|------------|
| 20X5 | \$25,000 | \$25,000 |
| 20X6 | 25,000 | 50,000 |
| 20X7 | 25,000 | 75,000 |
| 20X8 | 25,000 | 100,000 |

Because compensation cost is recognized only for awards for which the requisite service is provided, if the CEO left the company prior to the completion of the four years of requisite service, the cumulative compensation cost previously recognized would be reversed.

Graded-Vesting Employee Awards

4.079 When portions of an award vest in increments during the employee requisite service period, it is referred to as a *graded-vesting award*. For example, a share option award for 4,000 shares vests 25% at the end of each year for four years or 1,000 share options per year.

4.080 For an award with a graded-vesting schedule, if vesting is based *only* on a service condition, the entity is required to make an accounting policy decision to recognize compensation cost for the award *either* (1) over the employee requisite service period for each separately vesting portion (or tranche) of the award as if the award is, in-substance, multiple awards (tranche-by-tranche method), *or* (2) over the employee requisite service period for the entire award (for attribution purposes the award is treated as though it were cliff vesting). The policy election is consistently applied to all employee share-based payment awards with graded vesting based on service conditions. If the award does not qualify for the graded-vesting policy election, compensation cost would be recognized using the tranche-by-tranche method. ASC paragraphs 718-10-35-8 and 718-10-55-25 through 55-27

4.080a ASC paragraphs 718-10-55-98 through 55-99 state that the accounting policy election for awards with graded vesting applies when the service inception date and the grant date is the same for all tranches of the award. When considering whether the service inception date and the grant date for all tranches is the same, we believe a company should choose one of two approaches: (1) the service inception date and the grant date for the entire award must be the same date, or (2) the service inception date for all tranches must be the same and the grant date for all tranches must be the same. See Examples 4.5 through 4.9 in evaluating whether the service inception and grant dates are the same.

4.080b For graded-vesting awards where compensation cost is recognized as one award over the entire employee requisite service period of the award, the cumulative amount of compensation cost recognized at any point in time must at least equal the portion of the grant-date fair value of the award that is vested at that date (i.e., the floor). An entity may recognize the floor by making a policy election, to be consistently applied, to either recognize a catch-up adjustment at the vesting date or anticipate the floor during the vesting period. ASC paragraphs 718-10-35-8 and 718-20-55-32

Example 4.14: Attribution of Compensation Cost for a Graded-Vesting Award – Straight-Line Basis

ABC Corp. grants 10,000 share options with a grant-date fair value of \$6 per share option to certain of its employees. These awards vest as follows: 5,000 share options vest at the end of the first year, and 2,500 share options vest at the end of the second and third years, respectively. ABC elects, as an accounting policy, to recognize compensation cost for graded-vesting awards on a straight-line basis.

Compensation cost recognized at each reporting date would be as follows:

| Year | Cumulative Compensation Cost on a Straight-Line Basis | Grant-Date Fair Value of Awards Vested to Date | Compensation Cost Recognized in the Period |
|-------------|--|---|---|
| 1 | \$20,000 | \$30,000 ¹ | \$30,000 |
| 2 | 40,000 | 45,000 ² | 15,000 ³ |
| 3 | 60,000 | 60,000 ⁴ | 15,000 ⁵ |

$$^1 5,000 \times \$6 = \$30,000$$

$$^2 (5,000 + 2,500) \times \$6 = \$45,000$$

$$^3 \$45,000 - \$30,000 = \$15,000$$

$$^4 (5,000 + 2,500 + 2,500) \times \$6 = \$60,000$$

$$^5 \$60,000 - (\$30,000 + \$15,000) = \$15,000$$

Alternatively, assume the same facts as above, except the awards vest as follows: 2,500 share options vest at the end of the first year and second year, and 5,000 share options vest at the end of the third year, and ABC elects, as an accounting policy, to recognize compensation cost for graded-vesting awards on a straight-line basis.

Compensation cost recognized each reporting date would be as follows:

| Year | Cumulative Compensation Cost on a Straight- Line Basis | Grant-Date Fair Value of Awards Vested to Date | Compensation Cost Recognized in the Period |
|------|---|--|--|
| 1 | \$20,000 | \$15,000 ¹ | \$20,000 |
| 2 | 40,000 | 30,000 ² | 20,000 ³ |
| 3 | 60,000 | 60,000 ⁴ | 20,000 ⁵ |

$$^1 2,500 \times \$6 = \$15,000$$

$$^2 (2,500 + 2,500) \times \$6 = \$30,000$$

$$^3 \$40,000 - \$20,000 = \$20,000$$

$$^4 (2,500 + 2,500 + 5,000) \times \$6 = \$60,000$$

$$^5 \$60,000 - (\$20,000 + \$20,000) = \$20,000$$

See Example 4.15 for an illustration of the attribution pattern if an entity elects to treat awards with graded vesting as multiple awards.

4.080c An award with graded vesting that vests each calendar year may have a service inception date that is some time after the beginning of the year. For example, an entity may grant an award with graded vesting on February 1 that vests 25% at the end of each calendar year for four years. If the entity elects to recognize the entire award on a straight-line basis, rather than recognizing 23.4% (11/47 months) of compensation cost by the end of the first year it would be required to recognize 25% in the first 11 months so that the cumulative amount recognized by the end of the year is at least equal to the floor as discussed in Paragraph 4.080b.

4.081 For awards that contain a service condition and a performance condition in which both are required for the award to vest, the policy election described in Paragraph 4.080 is generally unavailable to the company. Compensation cost for such awards is recognized on a tranche-by-tranche basis.

4.081a However, some companies have provisions in their awards that specify that an unvested award will become immediately vested on change of control of the company or

a liquidity event such as an initial public offering (IPO). ASC Topic 718 identifies the change of control of a company and liquidity events such as an IPO as performance conditions. When determining whether such a condition would preclude the company from applying its straight-line attribution policy to such awards, we believe that the company should evaluate these provisions to determine whether the condition is designed to function as a substantive performance condition or as a protective feature for grantees. This determination requires an evaluation of all relevant facts and circumstances including the underlying reasons why the condition was included in the award. To the extent that the condition is designed to function as a protective feature for grantees, we believe that condition does not preclude the company from electing straight-line attribution for awards with graded vesting if this is the only *performance* condition that the award contains (see Q&A 4.15aa).

Q&A 4.15aa: Attribution of Compensation Cost for an Award with a Service Condition and Accelerated Vesting on an IPO or Change of Control

Q. ABC Corp. grants 10,000 restricted shares that vest 33% at the end of each year over three years. In addition, the award contains a performance condition whereby upon an IPO or change of control any unvested shares immediately vest. ABC's policy is to recognize compensation cost for graded-vesting awards on a straight-line basis. Can ABC apply the straight-line method in recognizing compensation for these awards that include a performance condition?

A. Yes, while the awards include performance conditions, the conditions are designed to function as a protective feature because the IPO or change of control only accelerates vesting but is otherwise not required to vest.

In contrast, when both the performance condition and a service condition are required to vest (e.g., the grantee must complete certain years of service and the company must complete an IPO), the IPO performance condition is not designed to function as a protective feature and the straight-line policy election is precluded. See Example 4.23b for an illustration of the attribution of an award that requires both the IPO performance condition and service to be met.

4.082 Companies may have awards that contain both a service condition and a market condition. As described beginning at Paragraph 4.068, market conditions are exercisability rather than vesting conditions for the purposes of applying ASC Topic 718 and therefore are reflected in the determination of the grant-date fair value of the award rather than in the attribution of the award. Generally graded-vesting attribution applies to awards with graded vesting that have both a service condition and a market condition, however we understand there is diversity in practice.

4.083 Use of the broad policy election in applying ASC subparagraph 718-10-55-108(c)(2) (see Paragraphs 4.008 through 4.024) implicitly involves determining that the award contains a performance and/or market condition. If, upon being granted, the award contains a graded-vesting schedule, a conclusion in applying ASC subparagraph 718-10-

55-108(c)(2) that the award contains a performance condition would preclude the company from applying the straight-line policy election to the award because the award does not vest only based on service as required by ASC paragraph 718-10-35-8 (even if the performance or market conditions are satisfied and only service conditions remain at the grant date). Consequently, the company would be required to recognize compensation cost on a tranche-by-tranche basis.

Example 4.15: Applying a *Broad-Broad* Policy Election in Accordance with ASC Subparagraph 718-10-55-108(c)(2) to an Award with Graded Vesting

ABC Corp will issue 12,000 nonvested share awards in accordance with its annual compensation plan. The awards contain a performance condition that requires the entity to increase EBITDA for December 31, 20X6 by 5% over the prior year EBITDA result. ABC determines that the service inception date precedes the grant date when applying a broad policy election under ASC subparagraph 718-10-55-108(c)(2). The service inception date for the awards is January 1, 20X6. The grant date of the awards will be January 1, 20X7 and the awards will have a grant-date fair value of \$6 per nonvested share. The awards will vest on a graded vesting schedule as follows:

| Number of Shares | Vesting Date |
|------------------|-------------------|
| 4,000 | December 31, 20X7 |
| 4,000 | December 31, 20X8 |
| 4,000 | December 31, 20X9 |

Assuming that the performance condition is met on December 31, 20X6, in applying a tranche-by-tranche attribution, ABC would recognize the following amounts in the reporting periods 20X6-20X9:

| Vesting Tranche | 20X6 | 20X7 | 20X8 | 20X9 |
|---|-----------------|---------------|---------------|--------------|
| 20X7: 4,000 shares × \$6/ 2 year service period | \$12,000 | 12,000 | — | — |
| 20X8: 4,000 shares × \$6/ 3 year service period | 8,000 | 8,000 | 8,000 | — |
| 20X9: 4,000 shares × \$6/ 4 year service period | 6,000 | 6,000 | 6,000 | 6,000 |
| Compensation cost for the year | \$26,000 | 26,000 | 14,000 | 6,000 |

4.084 Changes in the attribution approach made after the accounting policy election would require the entity to support the accounting change on the basis of preferability and to retrospectively apply the newly adopted policy in accordance with ASC Topic 250, *Accounting Changes and Error Corrections*.

4.085 Under ASC Topic 718, the method of attribution recognition is *not* dependent on the entity's choice of valuation technique. Therefore, the entity may value each vesting tranche separately when determining grant-date fair value, but, for awards with only a service condition with graded vesting, it may recognize the entire award's compensation cost using either straight-line or graded attribution over the requisite service period. ASC paragraphs 718-10-35-8 and 718-20-55-26

4.086 An entity that makes an accounting policy decision to treat awards with a graded-vesting schedule as a series of separate awards or tranches when recognizing compensation cost may, but is not required, to account for each separately vesting tranche as a separate award for valuation purposes. For example, a share option award of 10,000 share options that vest 25% at the end of each year for four years is considered to be four separate awards of 2,500 share options. In addition, grant-date fair value would be calculated separately for each tranche using a different expected term and, if applicable, expected volatility or risk-free rate, etc., for each tranche. Compensation cost for each tranche would be recognized over the requisite service period for that specific tranche. For an award that vests 25% at the end of each year for four years, the requisite service period of the first tranche is one year; the requisite service period of the second tranche is two years; etc. Therefore, compensation cost for the first tranche is recognized over its one-year requisite service period, while compensation cost for the second tranche is recognized over its two-year requisite service period, and so on. This results in *front-loading* of compensation cost.

Example 4.16: Attributing Compensation Cost for a Graded-Vesting Award – Tranche by Tranche

Background

| | |
|---|--|
| Grant date | January 1, 20X5 |
| Number of employees | 300 |
| Share options granted per employee | 1,500 |
| Vesting schedule | 1/3 at end of each year |
| Estimated and actual forfeitures | None |
| Grant-date fair value calculated for each vesting tranche | \$5 (20X5 vesting tranche), \$5.75 (20X6 vesting tranche), and \$6.50 (20X7 vesting tranche) |

| Vesting Tranche | Number of Employees | Number of Share Options per Vesting Tranche |
|-----------------|---------------------|---|
| 20X5 | 300 | $300 \times (1,500 \times 1/3) = 150,000$ share options |
| 20X6 | 300 | $300 \times (1,500 \times 1/3) = 150,000$ share options |
| 20X7 | 300 | $300 \times (1,500 \times 1/3) = 150,000$ share options |

| Vesting Tranche | Share Options per Vesting Tranche | Grant-Date Fair Value per Share Option | Compensation Cost per Vesting Tranche |
|-----------------|-----------------------------------|--|---------------------------------------|
| 20X5 | 150,000 | \$5.00 | \$ 750,000 |
| 20X6 | 150,000 | 5.75 | 862,500 |
| 20X7 | 150,000 | 6.50 | 975,000 |
| | | | \$ <u>2,587,500</u> |

| Compensation cost recognized: | | | |
|---------------------------------------|---------------------|------------------|------------------|
| Vesting Tranche | 20X5 | 20X6 | 20X7 |
| 20X5 | \$ 750,000 | — | — |
| 20X6 | 431,250 | 431,250 | — |
| 20X7 | 325,000 | 325,000 | 325,000 |
| Compensation cost for the year | \$ <u>1,506,250</u> | <u>756,250</u> | <u>325,000</u> |
| Cumulative compensation cost | \$ <u>1,506,250</u> | <u>2,262,500</u> | <u>2,587,500</u> |

Had the entity elected to recognize compensation cost on a straight-line basis for graded-vesting awards, compensation cost recognized each year over the three-year vesting period would have been \$862,500 ($\$2,587,500 / 3$). If the entity had elected to recognize compensation cost ratably over the three-year period, it could have calculated the grant-date fair value using a single weighted-average expected life for the entire award, which may have resulted in a different cumulative compensation cost. Refer to Example 4.17, which illustrates the effects of forfeitures on this example when an entity elects to estimate forfeitures. ASC paragraph 718-20-55-32

ATTRIBUTION FOR NONEMPLOYEE AWARDS

4.086a For awards granted to nonemployees, compensation cost attribution may be the same or different from that of employee awards. For nonemployee equity-classified awards, a grantor recognizes compensation cost for the goods acquired or services received in the same manner as if the company had paid cash for the goods or services. Therefore, a company should consider the nature of what it is receiving and the pattern of performance by the nonemployee to determine the appropriate period(s) and pattern in which to recognize cost. Because the attribution method for nonemployee awards is in the same manner as if the company had paid cash for the goods or services, the existing policy election of a graded or straight-line basis for attribution of service condition awards with graded vesting only applies to employee awards. Companies that issue nonemployee awards should apply judgment in determining the attribution of the cost of such awards. ASC paragraph 718-10-25-2C.

4.086b Similar to the employee requisite service period, the initial determination of the nonemployee vesting period is made at the grant date (or the service inception date, if it precedes the grant date) based on an analysis of the service, performance, or market

conditions (or a combination thereof) that are explicit, implicit, or derived in or from the terms of the award. See Paragraph 4.053a. ASC paragraph 718-10-25-2B

4.086c If fully vested, nonforfeitable equity-classified instruments are granted at the date the grantor and nonemployee enter into an agreement for goods or services, and there is no specific performance condition required to be met by the nonemployee, a grantor will recognize the cost for the grant of equity instruments when they are granted and compensation cost is recognized immediately. Or, depending on the circumstances, instead of compensation cost being recognized immediately, a prepaid asset (or contra-equity) may be recognized instead. This is because the nonemployee has no obligation to perform to earn the equity instruments (i.e., fully vested, nonforfeitable and no performance conditions). However, if there is a specific performance condition to be met by the nonemployee, or the instruments are otherwise unvested or forfeitable, then compensation cost is recognized in the same period(s) and in the same manner as if the company had paid cash for the goods or services instead of paying with, or using, the share-based payment awards. A grantor will recognize a corresponding credit to equity (additional paid-in-capital) when it recognizes the related compensation cost. ASC paragraphs 718-10-35-1A through 35-1D and 718-10-45-3

Example 4.16a: Attribution of Compensation Cost for Stock Options Provided to a Supplier

On March 31, 20X2, ABC enters into an agreement with a supplier to provide inventory with deliveries scheduled on June 30, 20X2 and September 30, 20X2. The supplier agrees to deliver the inventory in exchange for 500 stock options for each inventory delivery. The grant date requirements are met on the date ABC enters into the agreement (March 31, 20X2).

ABC recognizes the grant-date fair value for the first 500 stock options on June 30, 20X2 and for the second 500 stock options on September 30, 20X2 when it receives the inventory.

Example 4.16b: Attribution of Compensation Cost for Stock Options Provided to a Service Provider

On December 15, 20X1, ABC enters into an agreement with a public relations firm to provide services throughout the 20X2 year. The public relations firm agrees to provide the services in exchange for 500 stock options. The grant date requirements are met on the date ABC enters into the agreement (December 15, 20X1).

ABC recognizes the grant-date fair value for the 500 stock options when it receives the services. For example, if the public relations firm provides the services relatively evenly each month, the expense is recognized ratably each month during the year.

ESTIMATING FORFEITURES – FOR BOTH EMPLOYEE AND NONEMPLOYEE AWARDS

4.087 The total amount of compensation cost recognized for an employee award is based on the number of awards for which the requisite service or performance condition is completed. The total amount of compensation cost recognized for a nonemployee award is based on the number of awards provided in exchange for goods delivered or services rendered. ASC Section 718-10-30-11 uses the term *forfeitures* to refer to awards (both equity-classified and liability-classified) that are terminated when employees and nonemployees do not satisfy a service or performance condition (e.g., when a good is not delivered for a nonemployee award, or a service is not rendered for either an employee or nonemployee award). The forfeiture of an award is distinguished from the expiration of an award. Expiration of an award is a failure to exercise (e.g., the award is never in-the-money). Compensation cost is recognized for all awards when the grantees have delivered the goods or satisfied the service or performance condition whether or not the award is ultimately exercised. Conversely, when a grantee fails to deliver the goods or satisfy a service or performance condition (a forfeiture of the award), compensation cost previously recognized is reversed.

4.087a An entity makes an entity-wide accounting policy decision to either (1) estimate the number of forfeitures in determining its initial accrual of compensation cost or (2) to recognize as an adjustment to compensation cost, the effects of forfeitures of awards as they occur. Under policy election (1), the total amount of compensation cost recognized for an award each period is based on the estimated number of awards that will ultimately vest. That estimate is revised if subsequent information indicates that the actual number of awards expected to vest will differ from the initial estimate. The cumulative effect on current and prior periods of a change in the estimated number of awards for which the requisite service is expected to be or has been rendered is recognized in compensation cost in the period of the change. Under policy election (2), compensation cost is initially recognized for the entire population of awards granted. Forfeitures are recognized in the period in which they occur. The reversal for known forfeitures is not accelerated if a forfeiture occurs after the period end but before the financial statements are issued. An entity makes separate forfeiture policy elections for employee awards and nonemployee awards, which may be the same (see Q&A 4.15a). However, the policy for nonemployee awards is inclusive of awards issued to customers. ASC paragraphs 718-10-35-1D and 35-3

Q&A 4.15a: Separate Entity-Wide Policy Election on Estimating Forfeitures for Employee and Nonemployee Awards

Q. While an entity is required to make an entity-wide policy election about forfeitures, does Topic 718 permit separate entity-wide policies for employee and nonemployee awards?

A. Yes, ASC Topic 718 permits separate entity-wide policies for employee and nonemployee awards. For example, because of the different attributions for nonemployee

awards, an entity may consider whether a separate forfeiture accounting policy is more appropriate for nonemployee awards that differs from that made for employee awards.

We believe that a company should continue to differentiate between employee and nonemployee share-based payment awards within its accounting records, requiring separate tracking to account for them correctly.

4.087b In most situations, an entity will ultimately recognize the same amount of cumulative compensation cost under either policy election (1) or (2), representing the compensation cost for all awards that vested. However, companies that account for forfeitures as they occur will still have to estimate forfeitures of awards when accounting for (a) a modification of an award or (b) a replacement award in a business combination. In both of these circumstances, the forfeiture estimate can affect the cumulative amount of compensation cost recognized because the probability of ultimately vesting in the award affects the measurement of the impact of a modification. See the discussions in Section 5 related to modifications and Section 11 of KPMG Handbook, *Business Combinations*, related to replacement awards in a business combination.

4.087c The forfeiture election applies to awards with service conditions, which includes employee awards for providing employment services and also nonemployee awards in which the nonemployee is delivering goods or rendering services. For awards with performance conditions, compensation cost continues to be based on the best estimate of the outcome of awards. When there is a service condition for an award with an “AND” performance condition, the accounting policy election for forfeitures applies to the service condition leg of that award. In that circumstance, an entity would still determine its best estimate of outcome of the performance condition, and record compensation cost accordingly. The Board made this distinction so that an entity would not record compensation for the maximum number of awards that could be earned under the performance condition, only to reverse a portion of that amount for forfeitures if the final outcome results in less than full achievement of the awards.

Example 4.16c: Cliff-Vesting Awards with Accounting for Forfeitures When They Occur

On January 1, 20X5, ABC Corp. grants 900,000 share options to its employees with a grant-date fair value of \$10.00 per share option. The awards cliff vest after three years of service. ABC’s accounting policy is to account for employee award forfeitures as they occur. In 20X5, 20X6, and 20X7, share option forfeitures are 45,000, 50,000, and 60,000 share options, respectively.

The compensation cost to be recognized over the requisite service period is \$9,000,000 (900,000 x \$10), and the compensation cost to be recognized (excluding the effects of forfeitures) during each year of the 3-year vesting period is \$3,000,000 ($\$9,000,000 / 3$).

The table below summarizes the amounts recorded during each of the three years:

| | Total options forfeited (cumulative) | Options net of awards previously forfeited | Total compensation cost to be recognized | Compensation cost recorded prior to effect of actual forfeitures | Total compensation cost to reverse in the respective year for effect of actual forfeitures | Total compensation cost for the respective year net of forfeitures |
|------|--------------------------------------|--|--|--|--|--|
| 20X5 | 45,000 | 855,000 | \$8,550,000 ¹ | \$3,000,000 | (\$150,000) | \$2,850,000 |
| 20X6 | 95,000 | 805,000 | \$8,050,000 ² | \$2,850,000 | (\$333,333) ³ | \$2,516,667 |
| 20X7 | 155,000 | 745,000 | 7,450,000 ⁴ | \$2,683,333 | (\$600,000) ⁵ | \$2,083,333 |

Cumulative compensation cost over the three years is \$7,450,000, calculated as: 20X5 compensation cost of \$2,850,000 (\$3,000,000 - \$150,000) + 20X6 compensation cost of \$2,516,667 (\$2,850,000 - \$333,333) + 20X7 compensation cost of \$2,083,333 (\$2,683,333 - \$600,000). \$7,450,000 of total compensation cost also is calculated as the total amount of awards at the end of the three-year period of 745,000 (900,000 original awards – less total forfeitures of 155,000) x \$10 grant-date fair value.

1 855,000 x \$10.00

2 805,000 x \$10.00

3 50,000 share options forfeited x \$10 x (2 years/3 years) = \$333,333

4 745,000 x \$10.00

5 60,000 share options forfeited x \$10 x (3 years/3 years) = \$600,000

Example 4.16d: Award with both a Service and Performance Condition when Large-Scale Forfeitures Are Known

ABC Corp. approved a separation plan for certain employees (i.e., special termination benefit for voluntary termination under ASC Topic 712). Some employees have irrevocably accepted voluntary termination, and ABC has recorded a liability for special termination benefits. The employees that accepted voluntary termination also hold unvested awards that require satisfying a service and performance condition. The performance condition is probable of achievement and ABC's policy is to account for forfeitures as they occur.

Although it is certain that the employees that accepted the special termination benefits will terminate and forfeit the awards before the performance condition is achieved, ABC should continue to evaluate the performance condition at the entity level, and not at the level of the individual employees because the voluntary termination does not affect the probability that the performance condition will be met. Therefore, as long as meeting the performance condition is probable, compensation cost should continue to be recognized until the awards are legally forfeited on the termination date. That is, the forfeiture does not occur at the acceptance date, but the date the employee terminates employment.

4.088 The effects of expected forfeitures on the recognition of compensation cost is illustrated for an award with graded vesting in Example 4.17, which is based on the information from Example 4.16 and adds an assumption that the entity elects to estimate the number of forfeitures. Note that because the attribution method for nonemployee awards is in the same manner as if the company had paid cash for the goods or services, the existing policy election of a graded or straight-line basis for attribution of service condition awards with graded vesting only applies to employee awards. ASC paragraph 718-10-35-3

Example 4.17: Graded-Vesting Employee Award with Estimated Forfeitures

Background

| | |
|--|-------------------------|
| Grant date | January 1, 20X5 |
| Number of employees | 300 |
| Share options granted per employee | 1,500 |
| Vesting schedule | 1/3 at end of each year |
| Estimated and actual forfeitures | 3% per year |
| Grant-date fair value for each vesting tranche | \$5, \$5.75, and \$6.50 |

| Vesting Tranche | Number of Employees | Number of Share Options per Vesting Tranche |
|-----------------|--------------------------------|---|
| 20X5 | $300 - (300 \times .03) = 291$ | $291 \times (1,500 \times 1/3) = 145,500$ |
| 20X6 | $291 - (291 \times .03) = 282$ | $282 \times (1,500 \times 1/3) = 141,000$ |
| 20X7 | $282 - (282 \times .03) = 274$ | $274 \times (1,500 \times 1/3) = 137,000$ |

| Vesting Tranche | Share Options per Vesting Tranche | Grant-Date Fair Value per Share Option | Compensation Cost per Vesting Tranche |
|-----------------|-----------------------------------|--|---------------------------------------|
| 20X5 | 145,500 | \$5.00 | \$727,500 |
| 20X6 | 141,000 | \$5.75 | 810,750 |
| 20X7 | 137,000 | \$6.50 | 890,500 |
| | | | <u>\$2,428,750</u> |

Compensation cost recognized

| Vesting Tranche | 20X5 | 20X6 | 20X7 |
|---------------------------------------|---------------------|------------------|------------------|
| 20X5 | \$ 727,500 | — | — |
| 20X6 | 405,375 | 405,375 | — |
| 20X7 | 296,833 | 296,833 | 296,834 |
| Compensation cost for the year | \$ 1,429,708 | 702,208 | 296,834 |
| Cumulative compensation cost | \$ 1,429,708 | 2,131,916 | 2,428,750 |

Alternatively, if the entity had made an accounting policy decision to recognize compensation cost for awards with graded vesting on a straight-line basis, compensation cost would have been recognized as follows:

| | |
|--|--------------------------|
| Total compensation cost for all tranches | \$ 2,428,750 |
| Three-year service period (20X5, 20X6, and 20X7) | <u>3</u> |
| Compensation cost per year | <u><u>\$ 809,583</u></u> |

Notes: This example assumes there is no change in the estimated forfeitures over the requisite service period. In addition, regardless of the attribution policy selected, grant-date fair value could have been calculated for the entire award, as opposed to on a tranche-by-tranche basis.

Example 4.18: Attribution of Compensation Cost for a Graded-Vesting Employee Award Adjusted for Actual Forfeitures

ABC Corp. grants 10,000 share options with a graded vesting service condition. The share options vest 25% at the end of each year over the next four years. ABC has elected a policy to recognize compensation cost on a straight-line basis over the requisite service period of the entire award (i.e., four years). ABC has also elected a policy to estimate the number of forfeitures in determining the amount of compensation cost to record each period. The grant-date fair value of the share options is determined to be \$6 per share option and the estimated forfeiture rate is 8%, or 800 share options over the four-year service period.

Actual forfeitures were as follows:

| | |
|--------|-------------------|
| Year 1 | 100 share options |
| Year 2 | 200 share options |
| Year 3 | 250 share options |
| Year 4 | 250 share options |

Using ABC's policy election to recognize the compensation cost on a straight-line basis, the compensation cost calculated using estimated forfeitures would be:

$$[10,000 - 800] \times \$6 / 4 \text{ years} = \$13,800 \text{ per year}$$

However, the cumulative compensation cost recognized at any point in time must at least equal the portion of the grant-date fair value of the award that is vested at that date (i.e., the *floor*). Consequently, the effect of estimated versus actual forfeitures is considered in determining the compensation cost to recognize each period. The minimum cumulative amount of compensation cost to be recognized at the end of each year is calculated as:

$$\text{Year 1} - [2,500 - 100 \text{ actual forfeitures}] \times \$6 = \$14,400$$

$$\text{Year 2} - [5,000 - 300 \text{ actual forfeitures}] \times \$6 = \$28,200$$

$$\text{Year 3} - [7,500 - 550 \text{ actual forfeitures}] \times \$6 = \$41,700$$

$$\text{Year 4} - [10,000 - 800 \text{ actual forfeitures}] \times \$6 = \$55,200$$

| Year | Grant-date fair value awards vested to date | Compensation cost recognized in the period |
|------|---|--|
| 1 | \$14,400 | \$14,400 |
| 2 | 28,200 | 13,800 |
| 3 | 41,700 | 13,500 |
| 4 | 55,200 | 13,500 |

Example 4.19: Cliff-Vesting Awards with Estimated Forfeitures

Assume that ABC Corp. grants 10,000 share options to employees, with a grant-date fair value of \$10 per share option. The awards cliff vest after four years of rendering service. ABC has elected a policy to estimate the number of forfeitures in determining the amount of compensation cost to record each period. ABC estimates that 10% of the awards will be forfeited before the end of the requisite service period. If the actual rate of forfeitures equals 10%, ABC would recognize compensation cost of \$22,500 per year (9,000 share options expected to vest \times \$10 grant-date fair value / four-year requisite service period). It would adjust its estimate of forfeitures each period, as needed.

Example 4.20: Applying Estimate of Forfeitures to Nonvested Share Awards Containing a Contingent Repurchase Feature

On January 1, 20X6, ABC Corp. grants 10,000 nonvested shares to employees. The nonvested shares have a fair value of \$10 per share (the market price of the stock on the grant date) and cliff vest after three years of service. ABC elects a policy to estimate the

number of forfeitures in determining the amount of compensation cost to record each period. ABC estimates that 10% of the awards will be forfeited. Actual forfeitures equal 10%.

The award contains a contingent cash repurchase feature requiring ABC to reacquire the shares at the stock's then-current market price upon a change in control of the company. However, throughout the employee requisite service period, it is improbable that a change in control will occur. Ninety percent of the nonvested shares vest on December 31, 20X8. However, all of the forfeitures occurred in 20X8. Therefore, at December 31, 20X6 and 20X7, there were 10,000 nonvested share awards outstanding. Because ABC is an SEC registrant, it also applies the provision of ASC paragraph 480-10-S99-3 as discussed in Paragraph 3.104 and Example 3.22. The amount of compensation cost to recognize each period and the amount to be reported outside of permanent equity at each balance sheet date would be:

| Date | Compensation Cost for the Year | Cumulative Amount Recorded in Permanent Equity | Redemption Amount Recorded Outside of Permanent Equity |
|----------|--------------------------------|--|--|
| 12/31/X6 | \$30,000 ¹ | \$0 | \$33,333 ² |
| 12/31/X7 | \$30,000 | \$0 | \$66,666 |
| 12/31/X8 | \$30,000 | \$0 | \$90,000 |

¹ Compensation cost for the year including estimated forfeitures = (10,000 shares × \$10) × 90% (100% - 10% estimated forfeitures) × 1/3 years = \$30,000 each year

² ASC paragraph 480-10-S99-3 requires the amount recorded outside permanent equity to be based on the grant-date redemption value (which is the stock's market price in this example) multiplied by the proportion of the service provided to date in accordance with the vesting terms of the award. This grant-date redemption value would not change as long as the occurrence of the redemption feature is not probable. The amount recorded outside permanent equity is based on the actual number of nonvested shares outstanding at each balance sheet date ($\$10 \times 10,000$) × 1/3 years at December 31, 20X6 = \$33,333.

4.089 As discussed in Paragraph 4.087, the term *forfeiture* refers only to awards that are terminated when a grantee departs before delivering the goods or rendering services, or failing to achieve a performance condition. No compensation cost is recognized for an award that a grantee forfeits because the goods have not been delivered or services have not been rendered, or the performance condition has not been satisfied. In contrast, previously recognized compensation cost is not reversed for share options that expire unexercised after delivering the goods or rendering services, or achieving a performance condition because the awards have lapsed or expired as opposed to being forfeited by the grantee. ASC paragraphs 718-10-35-3 and 25-21

Q&A 4.15b: Effect of Chapter 11 Reorganization on Assumed Forfeiture Rates

Q. ABC Corp. estimates its expected forfeitures. If management of ABC, operating under Chapter 11 Reorganization, believes it is probable that some or all of the shares of common stock to be issued upon exercise of options and/or vesting of restricted stock will be canceled in connection with the reorganization plan, should ABC revise its assumed forfeiture rate when recording compensation cost under ASC Topic 718?

A. No. We believe that an entity should not adjust its forfeiture assumptions as a result of management's belief that some or all of the stock to be issued upon exercise of options and/or vesting of restricted stock will be canceled in connection with a Chapter 11 Reorganization.

Management would not reflect anticipated cancellations in the current measurement of compensation because the success of the Chapter 11 Reorganization is unknown. Therefore, ABC should continue to follow ASC Topic 718 to recognize share-based compensation expense while operating under Chapter 11 Reorganization. When estimating forfeitures, ABC should consider all of the relevant facts and circumstances including, but not limited to, historical forfeiture rates and the impact of restructuring activities (e.g., a reduction in the work force) taken as a result of the bankruptcy reorganization process.

If a share-based compensation award is canceled or modified, ABC would follow the respective modification/cancellation guidance in ASC Topic 718. Refer to Q&A 5.9, which provides guidance about the cancellation of awards due to emergence from Chapter 11.

4.090 When an entity elects a policy to estimate the number of forfeitures, the assumed forfeiture is considered an accounting estimate, used in determining the periodic compensation cost. Changes in the forfeiture rate are therefore considered changes in an accounting estimate. As the entity revises the estimated rate of forfeitures during the employee's requisite service period (or the nonemployee's vesting period, for nonemployee awards), the effect of the change in the estimated number of awards expected to vest is recognized in the current period. Because changes in the actual or estimated number of forfeitures affect the number of instruments for which compensation cost is recognized and, therefore, the total amount of compensation cost, the effect of such changes is reflected as a cumulative adjustment in compensation cost in the period when the estimate is revised. Examples 4.21 and 4.22 illustrate the determination of compensation cost when changes occur in the estimated number of forfeitures during an employee's requisite service period. The examples also could apply to nonemployee awards in which a service is provided evenly over a vesting period, and forfeitures are estimated. In both examples, the entity has elected a policy to estimate the number of forfeitures in determining the amount of compensation cost to be recognized in each period. ASC paragraphs 718-10-55-78 and 55-79 and 718-10-35-1D

4.090a When estimating the number of forfeitures, a company may consider the historical rate of forfeitures and/or employee turnover to determine its forfeiture estimate. In addition, it may consider other relevant factors including, among other considerations, the intrinsic value of the awards on the grant date, share price volatility, the vesting period of the awards, whether the grant is to a large population of employees or a small group of executives, and the related effect on the forfeiture rate to determine the appropriate estimated forfeiture rate for that specific award grant.

Example 4.21: Change in Estimated Number of Forfeitures

-Background

| | |
|--|---|
| Share options granted | 10,000 share options |
| Vesting schedule | 100% at the end of Third Year (cliff vesting) |
| Estimated forfeiture rate | 6% per year |
| Actual forfeiture rate | 6% in Years 1 and 2; 3% in Year 3 |
| Share option grant-date fair value | \$10 per share option |
| Estimated compensation cost of award at grant date | $(10,000 \times .94 \times .94 \times .94) \times \$10 =$ \$83,060 |
| Compensation cost recognized per year | $\$83,060 / 3 = \$27,687$ |
| Compensation cost recognized in Year 3 | (3% actual forfeiture rate) |
| Total compensation cost to be recognized | $(10,000 \times .94 \times .94 \times .97) \times \$10 =$ \$85,710 |
| Compensation cost recognized in Year 1 | \$ 27,687 |
| Compensation cost recognized in Year 2 | \$ 27,687 |
| Compensation cost to recognize in Year 3 | \$ 30,336 |

Example 4.22: Change in Estimated Number of Forfeitures—Revision in More Than One Period

Background

| | |
|--|--|
| Share options granted | 10,000 share options |
| Vesting schedule | 100% at end of Fourth Year (cliff vesting) |
| Initial estimated forfeiture rate | 6% per year |
| Share option grant-date fair value | \$10 per share option |
| Estimated total compensation cost of award at grant date | $(10,000 \times .94 \times .94 \times .94 \times .94) \times \$10 =$ \$78,070 |
| Compensation cost recognized in Year 1 | $\$78,070 / 4 = \$19,517$ |
| Change in estimated forfeiture rate is determined at the end of Year 2 (based on | Actual forfeitures are 6% in Year 1 and 4% in Year 2; |

| | |
|--|---|
| the actual experience in Years 1 and 2) | Estimated forfeitures for Years 3 and 4 are 3% per year |
| Estimated total compensation cost of award calculated at the end of Year 2 based on the change of estimate | $(10,000 \times .94 \times .96 \times .97 \times .97) \times \$10 = \$84,900$ |
| Cumulative compensation cost to be recognized at end of Year 2 | $\$84,900 \times 2/4\text{years} = \$42,450$ |
| Compensation cost recognized in Year 1 | \$ 19,517 |
| Compensation cost to recognize in Year 2 | \$ 22,933 ($\$42,450 - \$19,517$) |
| Compensation cost recognized in Year 3, is based on revised estimate of 3% forfeitures in Year 3, which equaled the actual forfeiture rate in Year 3 | $\$84,900 / 4 \text{ years} = \$21,225$ |
| Final actual forfeiture rates for all years | 6% in Year 1, 4% in Year 2, 3% in Year 3, 4% in Year 4 |
| Total compensation cost of award (based on actual forfeitures) | $(10,000 \times .94 \times .96 \times .97 \times .96) \times \$10 = \$84,030$ |
| Compensation cost recognized in Year 1 | \$ 19,517 |
| Compensation cost recognized in Year 2 | 22,933 |
| Compensation cost recognized in Year 3 | 21,225 |
| Compensation cost to recognize in Year 4 | 20,355 |

Example 4.22a: Record Forfeitures as They Occur

Background

| | |
|---|---|
| Share options granted | 10,000 share options |
| Vesting schedule | 100% at end of Fourth Year (cliff vesting) |
| Share option grant-date fair value | \$10 per share option |
| Forfeiture policy | Record forfeitures as they occur |
| Estimated total compensation cost of award at grant date | $10,000 \times \$10 = \$100,000$ |
| Compensation cost recognized in Year 1 | $\$100,000 / 4 = \$25,000$ |
| Actual forfeitures in Year 1 | 600 awards |
| Compensation cost recognized in Year 1 net of forfeitures | $\$25,000 - (600 \times \$10 / 4 \text{ years}) = \$23,500$ |

| | |
|---|---|
| Actual forfeitures in Year 2 | 376 awards |
| Estimated total compensation cost of award calculated at the end of Year 2 | 9,024 (i.e., 10,000 – 600 – 376 awards) x \$10 = \$90,240 |
| Cumulative compensation cost to be recognized at end of Year 2 | \$90,240 × 2/4years = \$45,120 |
| Compensation cost recognized in Year 1 | \$ 23,500 |
| Compensation cost to recognize in Year 2 | \$ 21,620 (\$45,120 - \$23,500) |
| Actual forfeitures in Year 3 | 270 awards |
| Estimated total compensation cost of award calculated at the end of Year 3 | 8,754 (i.e., 10,000 – 600 – 376 - 270 awards) x \$10 = \$87,540 |
| Cumulative compensation cost to be recognized at end of Year 3 | \$87,540 × 3/4years = \$65,655 |
| Compensation cost recognized in Year 1 | \$ 23,500 |
| Compensation cost recognized in Year 2 | \$ 21,620 |
| Compensation cost to recognize in Year 3 | \$ 20,535 (65,655 – 23,500 – 21,620) |
| Actual forfeitures in Year 4 | 350 awards |
| Estimated total compensation cost of award calculated at the end of Year 4 | 8,404 (i.e., 10,000 – 600 – 376 – 270 – 350 awards) x \$10 = \$84,040 |
| Compensation cost recognized in Year 1 | \$ 23,500 |
| Compensation cost recognized in Year 2 | \$ 21,620 |
| Compensation cost recognized in Year 3 | \$ 20,535 |
| Compensation cost to recognize in Year 3 | \$ 18,385 |
| Total | \$ 84,040 |
| Total compensation cost recognized over the four-year period is \$84,040, which is the equivalent of 8,404 awards x \$10 grant date fair value. | |

4.091 Examples 4.21, 4.22 and 4.22a only consider the effects of changes in *annual* forfeitures on compensation cost. Entities that elect a policy to estimate the number of forfeitures should evaluate their estimated rate of forfeitures each reporting period and make appropriate adjustments to compensation cost, as needed, after considering all available evidence both before and after the reporting date that would affect an entity's estimate of the forfeiture rate. To the extent that the actual forfeitures are significantly greater than the estimated rate of forfeitures, it is possible that an individual reporting period may recognize a reduction in compensation cost (income) as previously accrued compensation cost is reversed.

ATTRIBUTION PERIOD FOR EMPLOYEE AWARDS WITH PERFORMANCE CONDITIONS

4.092 For awards with a performance condition, compensation cost would be recognized when the achievement of the performance condition is considered probable of achievement. *Probable* has the same meaning in ASC Topic 718 as it does in ASC Topic 450. If a performance award has more than one outcome that is probable of achievement, recognition of compensation cost would be based on the condition that is the most likely outcome. During the service period, a cumulative catch-up approach is used to account for changes in the assessment of which award is more likely to be earned, assuming there is no change to the requisite service period (see also Paragraph 4.096). ASC paragraph 718-10-25-20

Example 4.23: Award Containing a Performance Condition with an Explicit Service Period

Background

| | |
|---|--|
| Share options granted | 25,000 share options |
| Vesting conditions | Vesting occurs if Product X's market share exceeds 25% at the end of four years |
| Entity elects a policy to estimate the number of forfeitures - Estimated and actual forfeiture rate | 8% in four years |
| Probability assessment at date of grant related to performance condition | Condition is deemed not to be probable based on current projections |
| Grant-date fair value | \$8 per share option |
| Change in probability assessment | During Year 3, Product X's market share is projected to be 30% at the end of four years. Therefore, the performance condition is now deemed to be probable of achievement. |
| Total estimated compensation cost of award at grant date | $(25,000 \times .92) \times \$8 = \$184,000$ |
| Compensation cost recognized in Years 1 and 2 | \$0 |
| Compensation cost recognized in Year 3: | |
| Compensation cost per year if performance condition is probable of achievement | $\$184,000 / 4 \text{ years} = \$46,000$ |
| Cumulative cost to be recognized through Year 3 | $\$46,000 \times 3 \text{ years} = \$138,000$ |
| Compensation cost previously recognized | \$0 |
| Compensation cost recognized in Year 3 | \$138,000 |

| | |
|--|----------|
| Compensation cost to be recognized in Year 4 (assuming performance target is achieved) | \$46,000 |
|--|----------|

As a result of improved sales of Product X, the performance condition becomes probable of achievement during Year 3. If, in this example, Product X's market share does not exceed 25% at the end of four years, previously recognized compensation cost would be reversed resulting in a reduction in compensation cost of \$138,000 in Year 4.

Example 4.23a: Award Containing a Performance Condition with an Explicit Service Period and a Change in Estimated Forfeitures

Background

| | |
|--|--|
| Share options granted | 26,250 share options |
| Vesting conditions | Vesting occurs if Product X's market share exceeds 25% at the end of three years |
| Entity elects a policy to estimate the number of forfeitures - | |
| Estimated forfeiture rate | 8% |
| Probability assessment at date of grant related to performance condition | Condition is deemed to be probable based on current projections |
| Grant-date fair value | \$8 per share option |
| Year 2 estimated forfeitures | 15% |
| Actual forfeitures at the end of Year 3 | 15% |

As a result of applying the cumulative catch-up approach, Years' 2 and 3 compensation cost is the difference between the total compensation expense to be recognized using a 15% forfeiture rate and total compensation expense recognized in Year 1 as follows.

| | |
|--|--|
| Total estimated compensation cost of award at grant date | $(26,250 \text{ share options} \times .92) \times \$8 = \$193,200$ |
| Compensation cost recognized in Year 1 | $\$193,200 / 3 \text{ years} = \$64,400$ |
| Compensation cost recognized in Years 2 and 3: | |
| Total compensation cost after forfeiture rate is estimated to be 15% | $(26,250 \text{ share options} \times .85) \times \$8 = \$178,500$ |

| | |
|--|---|
| Compensation cost not yet recognized | \$178,500 – less Year 1 of \$64,400 = \$114,100 |
| Compensation cost to be recognized in Years 2 and 3 (assuming the performance target remains probable and is achieved) | \$114,100 / 2 Years = \$57,050 |

Example 4.23b: Award Containing a Performance Condition with an Implicit Service Period Which Becomes an Explicit Service Period upon IPO

Background

| | |
|--|---|
| Share options granted | 12,000 share options |
| Vesting conditions | If the entity successfully completes an IPO then the shares vest annually over a 3-year period post-IPO |
| Probability assessment at date of grant related to performance condition | Condition is deemed to be not probable due to the IPO performance condition |
| Grant-date fair value | \$6 per share option |

The entity did not recognize any compensation cost for Year 1, as the awards were not probable of vesting because the IPO had not yet occurred. At the beginning of Year 2, the entity successfully completed the IPO. On the date of the IPO, the service period becomes explicit, and is 3 years post-IPO. As the shares vest annually over the 3-year period post-IPO, the entity recognizes compensation expense for a cumulative catch-up amount in Year 2 upon IPO, which would be calculated as the amount of graded vesting that would have been recognized considering the one year of service provided prior to the IPO year, as follows:

| Vesting Tranche | Pre-IPO year (Year 1) | 1 year post IPO (Year 2) | 2 years post IPO (Year 3) | 3 years post IPO (Year 4) |
|--|-----------------------------|--------------------------------|---------------------------------|------------------------------------|
| IPO +1 year: 4,000 shares × \$6/ 2 years | 12,000 | 12,000 | - | - |
| IPO + 2 years: 4,000 shares × \$6/ 3 years | 8,000 | 8,000 | 8,000 | - |
| IPO +3 years: 4,000 shares × \$6/ 4 years | 6,000 | 6,000 | 6,000 | 6,000 |
| Compensation attribution | 26,000 | 26,000 | 14,000 | 6,000 |

While there is \$26,000 attributed to Year 1, compensation expense recognized in Year 1 was \$0, as the awards were not probable of vesting until the IPO occurred.

In Year 2, on successful completion of the IPO, the \$26,000 attributed to Year 1 is recognized as compensation expense. Cumulative compensation recorded in Year 2, is \$52,000. Total compensation expense recognized over the 3-year period post-IPO is \$72,000 (12,000 share options * \$6 grant-date fair value).

Example 4.24: Performance Award That Contains Annual Performance Targets That Include Carryback and Carryforward Provisions

Background

On January 1, 20X6, ABC Corp. grants a nonvested stock award that vests 20% on December 31 of each year through December 31, 20Y0 based on the achievement of annual EBITDA targets. The annual EBITDA targets for each of the five years are specified and communicated to the grantees on January 1, 20X6. All other grant date conditions are met on January 1, 20X6. The failure to meet an EBITDA target in any one year does not affect the ability to vest in awards by meeting the EBITDA target in the other years. Because the failure to achieve the target in one year does not impact the ability to earn the awards in subsequent years, the award is deemed to be five separate grants, all having a grant date of January 1, 20X6 but each having a separate service inception date (see ASC paragraphs 718-10-55-93 and 55-94).

In addition to the annual targets, if the EBITDA amount for an annual period exceeds the target EBITDA for that year, the excess EBITDA amount may be carried forward to the next year (but only for the immediately following year) and be credited towards the achievement of the next year's EBITDA target. The award also contains a carryback provision in which any excess EBITDA amount earned in a year can be carried back to any prior year for which the EBITDA target was not met. Thus, depending on the facts and circumstances, and taking into consideration that an excess EBITDA can be carried forward one year but carried back to any period, the employee requisite service period to earn each award could be provided over the following minimum and maximum periods:

| Award | Minimum Service Period | Maximum Service Period |
|--------|------------------------|------------------------|
| Year 1 | Year 1 | Year 1 to Year 5 |
| Year 2 | Year 2 | Year 1 to Year 5 |
| Year 3 | Year 3 | Year 2 to Year 5 |
| Year 4 | Year 4 | Year 3 to Year 5 |
| Year 5 | Year 5 | Year 4 to Year 5 |

ABC should determine, based on its projections and other relevant data, the most likely outcome for each tranche and recognize compensation cost for each tranche over the implicit service period for each tranche based on the estimated outcome. ABC should continue to re-assess the implicit service period for each tranche and to revise its employee requisite service period if its expectations change for any tranche (see Examples 4.25 and 4.26).

4.093 As discussed in Paragraph 4.066, an implicit service period may need to be inferred from the performance condition of the award. For example, if an award vests upon the release of a new product (a performance condition) and that release is considered to be

probable of occurring in two years, the implicit service period is two years. Another example would be if an award vests when the entity's annual sales reach a specified target, the implicit service period would be determined based on a probability assessment of when the entity would achieve the target.

Q&A 4.16: Employee Requisite Service Period for a Performance-Based Award

Q. On January 1, 20X5, ABC Corp. grants 100,000 share options to members of management with an exercise price equal to the current market price of the shares. The share options vest when ABC's quarterly sales exceed \$100 million. The awards have a contractual term of six years. What is the employee's requisite service period of the award?

A. The *implicit* service period is estimated because there is no explicit service period stated in the award. In making its best estimate, ABC would look to budgeted or forecasted quarterly sales to determine when, if ever, it is probable that quarterly sales would exceed \$100 million. Assuming ABC projects that it is probable that quarterly sales would exceed \$100 million at the end of Year 4, the employee's requisite service period would be four years.

4.094 At the grant date, an entity would make its best estimate of the implicit service period based on the expected achievement of the performance condition. An estimate of the implicit service period is required even if the performance condition is not probable of achievement if the award is a share option or other similar instrument. The employee's requisite service period indirectly affects the grant-date fair value of the award because the expected term of those types of awards is an input into the valuation model and must be at least as long as the employee's requisite service period.

4.095 If a performance condition is considered probable of achievement at multiple points in time, the recognition of compensation cost is based on the most likely outcome (i.e., the point in time where achievement of the performance condition is most likely to occur).

4.096 The initial estimate of whether or when the achievement of the performance condition might occur may change as new information becomes available. If the total amount that is to be recognized as compensation cost changes, the cumulative effect on current and prior periods is recognized in the period of the change (i.e., a cumulative catch-up). The total amount of compensation cost may change because of a change to the quantity of instruments expected to vest or because the grant-date fair value used to measure the award changes (e.g., because a performance condition that affects exercise price becomes probable of satisfaction). In contrast, if the service period changes but the total amount to be recognized as compensation cost does not (e.g., the initially estimated service period changes solely because another market, performance, or service condition becomes the basis for the service period), any remaining unrecognized compensation cost

would be recognized prospectively over the revised employee's requisite service period. ASC paragraphs 718-10-55-77 through 55-79

Example 4.25: Performance Award with Multiple Implicit Service Periods – Part I

Background

| | |
|--|--|
| Share options granted on January 1, 20X5 | 100,000 share options |
| Grant-date fair value per share option | \$4.85 per share option |
| Vesting schedule | Vesting occurs when cumulative sales of Product X exceed 500,000 units |
| Contractual life | 5 years |
| Entity elects a policy to estimate the number of forfeitures; estimated and actual forfeiture rate | 3% per year |

Possible Outcomes

| Year (Requisite Service Period) | Probability Assessment |
|---------------------------------|------------------------|
| 20X5 (1 year) | Remote |
| 20X6 (2 years) | Remote |
| 20X7 (3 years) | Reasonably possible |
| 20X8 (4 years) | Probable |
| 20X9 (5 years) | Probable |

| | |
|--|---|
| Compensation cost of award at grant date recognized based on a four-year requisite service period (probable outcome) | $(100,000 \times .97 \times .97 \times .97 \times .97) \times \$4.85 = \$429,366$ |
| Compensation cost to be recognized per year | $\$429,366 / 4 \text{ years} = \$107,342$ |

As a result of improved sales of Product X, the performance condition is met in Year 3.

Compensation cost recognized in 20X7

| | |
|---|--|
| Revised compensation cost of award | $(100,000 \times .97 \times .97 \times .97) \times \$4.85 = \$442,645$ |
| Compensation cost previously recognized | $\$107,342 \times 2 \text{ years} = \$214,684$ |
| Compensation cost recognized in 20X7 | \$227,961 |

Through the end of 20X6, it is probable that the performance condition would be met during 20X8. Therefore, compensation cost was initially recognized over a four-year requisite service period. However, during 20X7 the performance condition was met resulting in a three-year requisite service period. While the grant-date fair value per award is unchanged, the compensation cost increased as a result of lower forfeitures due to the earlier achievement of the performance condition.

Example 4.26: Performance Award with Multiple Implicit Service Periods – Part II

Assume the same facts as in Example 4.25, except that at the beginning of 20X8 it is determined that the performance condition was not probable of achievement until 20X9 (five years compared to the original four-year assessment).

| | |
|--|--|
| Revised compensation cost of award | $(100,000 \times .97 \times .97 \times .97 \times .97 \times .97) \times \$4.85 = \$416,484$ |
| Cumulative compensation cost to recognize by the end of 20X8 | $\$416,484 / 5 \text{ year requisite service period} \times 4 \text{ years of service provided to date} = \$333,187$ |
| Cumulative compensation cost at end of 20X7 | $\$429,366 / 4 \text{ years} \times 3 \text{ years} = \$322,026$ |
| Compensation cost to recognize in 20X8 | $\$333,187 - \$322,026 = \$11,161$ |
| Compensation cost to recognize in 20X9 | $\$416,484 - \$333,187 = \$83,297$ |

Total compensation cost decreased as a result of additional forfeitures due to the longer period for achievement of the performance condition.

An alternative recognition method would be to recognize the effects of the change in the estimated forfeitures as an adjustment to the cumulative compensation cost-to-date, and to recognize the remaining unrecognized compensation cost prospectively over the revised requisite service period.

| | |
|---|-------------------------|
| Compensation cost cumulative adjustment to recognize at the beginning of 20X8 | \$ (9,661) ¹ |
| Compensation cost to recognize in 20X8 | \$ 52,059 ² |
| Compensation cost to recognize in 20X9 | \$ 52,059 ² |

¹ $(\$429,366 - \$416,484) \times 3/4$

² $(\$416,484 - (\$322,026 - \$9,661)) / 2$

If the entity's accounting policy is to recognize forfeitures as they occur, instead of estimating forfeitures, the initial and revised compensation cost of the award in this example would not consider expected forfeitures as shown in the calculation above. Instead, the entity would reverse compensation cost in the period the forfeitures actually occur. In this example, if the accounting policy had been to recognize forfeitures as they occur, compensation cost would be recognized over the remaining period given the change in the requisite service period.

4.097 The total compensation cost of an award may be changed as a result of several factors. The most common changes are the result of changes in the estimated outcome of a performance condition and, for companies that have a policy to estimate forfeitures, a change in the estimated cumulative forfeitures for the award. Changes in the estimated or

actual outcomes of a performance or service condition that affect the total amount of compensation cost of an award are recognized by reflecting a cumulative adjustment in compensation cost in the period when the total compensation cost is revised. In contrast, a change in estimate that does not affect the *amount* of compensation cost, but only affects the employee's requisite service period for recognition of that cost, is accounted for prospectively over the revised employee's requisite service period. For an entity that has an accounting policy to estimate forfeitures, a change in the best estimate of the outcome of the performance condition that also affects the employee's requisite service period also likely has an impact on estimated forfeitures. See Example 4.26 for an illustration of how to account for the changes that include elements to be accounted for prospectively as well as on a cumulative basis. ASC paragraphs 718-10-55-78 and 55-79

Example 4.27: Reflecting Changes in Estimates

On January 1, 20X6, ABC Corp. grants 1,000 share options to each of its 100 members of its sales force at an exercise price of \$10 per share option. The share options vest when ABC's quarterly sales increase by 15% over the prior quarter's sales. In addition, if the gross profit margin has increased by 20% when the share options vest, the exercise price of the share options will be \$8 per share. The share options have a contractual life of 10 years. Based on its forecasts, ABC estimates that it is probable that the 15% target will be achieved during the fourth quarter of 20X8 (three years from the date of grant), but that gross profit margin will not have increased by 20%. The grant-date fair value is \$4 per share option (based on the \$10 exercise price). Although not probable of achievement, ABC calculates that the grant-date fair value of the share options with the \$8 exercise price is \$6 per share option.

ABC's accounting policy is to estimate the number of forfeitures in determining the amount of compensation cost to be recognized in each period. ABC estimates that 10% of its sales force will leave prior to the end of the third year.

ABC would recognize compensation cost of \$360,000 over the three-year implicit service period ($\$120,000 \text{ per year} = 1,000 \times 100 \times \$4 \times 90\% \times 1/3$).

Scenario 1

At the beginning of 20X8 after the 20X7 financial statements have been issued, ABC now estimates that the quarterly sales target (15% increase) will not be met until the end of 20X9. ABC does not expect this to affect its estimate of forfeitures. This results in a change in the estimated requisite service period from three to four years. This change in estimate would be accounted for prospectively because the total compensation cost of \$360,000 has not changed. At that point, the unrecognized compensation cost is \$120,000 (\$120,000 was recognized in each of 20X6 and 20X7). The unrecognized amount would be recognized over the remaining two years of the new requisite service period at a rate of \$60,000 per year.

Scenario 2

At the end of 20X7 and before the 20X7 financial statements have been issued, ABC estimates that 20% of its sales force will leave prior to the end of the third year. There has been no change in the requisite service period, but the number of share options expected to vest, and therefore, the total amount of compensation cost has changed. This change in estimate would be recognized using a cumulative-effect adjustment to current compensation cost. Based on the revised estimate, through the end of 20X7, cumulative compensation cost would be \$213,333 (80,000 share options \times \$4 \times 2/3). For the year-ended 20X7, ABC would recognize compensation cost of \$93,333 (\$213,333 less \$120,000 recognized in 20X6).

Scenario 3

At the end of 20X7 and before the 20X7 financial statements have been issued, ABC estimates that it is probable that the gross profit margin will increase by 20% when the performance condition is met at the end of 20X8. ABC also expects this increased incentive will result in a reduction of the estimated forfeitures to 7%. There has been no change in the requisite service period, but the total amount of compensation cost has changed because the share options will have a lower exercise price and fewer forfeitures are expected. This change in estimate is recognized using a cumulative-catch-up adjustment for 20X7 compensation cost. Through the end of 20X7, the revised total compensation cost is \$372,000 (93,000 share options \times \$6 \times 2/3). For the year ended 20X7, ABC would recognize compensation cost of \$252,000 (\$372,000 less \$120,000 recognized in 20X6).

4.098 Recognition of compensation cost for an award with a performance condition is based on whether the performance condition is probable of achievement. Compensation cost is recognized if it is probable that the performance condition will be achieved. If it is not probable that the performance condition will be achieved, compensation cost would not be recognized. ASC paragraph 718-10-25-20

4.099 For awards with performance conditions that vest on an IPO, change in control or other liquidity events, the guidance in ASC paragraphs 805-20-55-50 and 55-51 is relevant for determining when the performance condition becomes probable of achievement. ASC paragraphs 805-20-55-50 and 55-51 state that liabilities that will be triggered by consummation of a business combination should be recorded only when the business combination is consummated. In practice, this interpretation of the meaning of *probable* is applied to other event-based performance conditions subject to significant uncertainty, such as IPOs and other change-in-control and liquidity events. Accordingly, the performance condition is not deemed to be probable of achievement until the consummation of the event, and therefore no compensation cost is recognized until the IPO, change of control, or other liquidity event occurs. However, we believe a performance condition triggered on the sale of a portion of an entity may be considered probable before consummation if the disposal group meets the ASC Topic 360 criteria to

be classified as held-for-sale (see KPMG Handbook, Discontinued operations, Section 4.2).

Q&A 4.17: Vesting Dependent on a Performance Condition - Scenario 1

Q. On January 1, 20X4, ABC Corp. grants 10,000 share options to members of management with an exercise price of \$20 per share. The share options vest when there is a change in control, which is defined in the agreement as an acquisition of more than 50% of ABC's shares and/or an IPO. Near year-end 20X6, management begins meeting with investment bankers to explore strategic alternatives. The Board of Directors agrees to either sell more than 50% of the shares to a new strategic investor or complete an IPO. It is expected that one of those alternatives will be implemented in six to nine months. Management of ABC believes that the performance conditions are probable of achievement as of December 31, 20X6, based on those decisions and time frames. Should compensation cost be recognized?

A. No. In practice, the guidance in ASC paragraphs 805-20-55-50 and 55-51 is also used to evaluate probability of IPOs and business combinations that are performance conditions in share-based payment awards. Accordingly, compensation cost would not be recorded for these awards until the business combination is consummated. See also Paragraphs 11.042 through 11.046 of KPMG Handbook, *Business Combinations* for additional discussion about how ABC would reflect the compensation cost in its financial statements.

Q&A 4.18: Vesting Dependent on a Performance Condition - Scenario 2

Q. On January 1, 20X4, ABC Corp. grants 10,000 share options to members of management with an exercise price of \$20 per share. The share options vest on obtaining FDA approval for certain of ABC's drug candidates currently under development. On December 31, 20X6, a committee of accounting and scientific personnel of ABC performed an analysis of the probability that FDA approval for certain drug candidates would be attained and the estimated dates when these approvals would occur. Management of ABC believes, based on the test results achieved in Phase III of the clinical trials and other information available to date, that ABC's application will be approved by the FDA within the next 12 months. Should compensation cost be recognized?

A. Perhaps. An entity should consider all available information in its determination of whether it is probable that the performance condition will be achieved. That assessment would include an evaluation of the strength of the research results (including the entity's historical success rates of obtaining FDA approval when it had similar research results) and other political and economic factors associated with obtaining FDA approval. Additionally, the evaluation should consider the fact that obtaining FDA approval of its

drug candidates is outside the entity's control. While there may be circumstances where the entity has sufficient evidence to support a conclusion that achievement of the performance condition is probable prior to receipt of the FDA approval, there also will be a number of circumstances where it is difficult to conclude that achievement is probable until shortly before approval (or, in some cases, upon approval) in light of the fact that ultimate achievement of the condition is beyond the control of the entity.

4.100 Some awards have provisions whereby the award vests based on satisfying service conditions but the grantee is unable to exercise the award until a performance condition is achieved. In some employee awards, an employee that terminates employment from the company before the performance condition is met, is able to retain the award and exercise it when and if the performance condition is met. That is, the employee would be entitled to benefit from the award regardless of whether the employee is rendering service on the date the performance target is achieved. The EITF debated these types of awards and reached a consensus that is described in ASU 2014-12, *Accounting for Share-Based Payments When the Terms of an Award Provide That a Performance Target Could Be Achieved after the Requisite Service Period*.

4.100a ASU 2014-12 requires that a performance target that could be achieved after an employee's requisite service period is accounted for as a performance condition that affects vesting. If at the grant date, it is probable that the performance condition will be achieved, compensation cost would be measured on the grant date and attributed to compensation cost over the period from the grant date until service is no longer required to retain the award. If at the grant date it is not probable that the performance condition will be achieved, the entity would still measure the grant date fair value of the awards but would not record any compensation cost until (and unless) the performance condition becomes probable of being achieved. The likelihood of the condition being achieved is not considered in the grant date fair value. In some circumstances, the accounting for the performance target as a performance condition will result in no compensation cost being recognized during the period in which the employee services are received. That is the case, for example, when the performance condition is an IPO or liquidity event and it becomes probable of being achieved after the service condition has been met. In other circumstances, companies would begin to recognize the compensation cost prior to the stated service condition being met. This commonly occurs for awards in plans with performance conditions and stated service conditions that permit employees who reach normal retirement age to retain their awards upon retirement, with exercisability and/or transferability remaining subject to the entity ultimately achieving the performance condition. Examples 4.28 and 4.29 illustrate each of these types of awards.

Example 4.28: Award Includes a Performance Condition Based on Occurrence of an IPO After Employment

On January 1, 20X6, ABC Corp. grants Restricted Stock Units (RSUs) to employees that include a three-year service condition. In addition, the RSUs will be settled only in shares if ABC completes an IPO within 10 years of the grant date. If there is no IPO by that

date, then the RSUs will expire worthless. However, once they have met the three-year service condition, employees may terminate service and will receive the underlying shares if the IPO occurs within the 10-year period. There are no expected or actual forfeitures during the service period and the IPO occurs in Year 5. The grant-date fair value of the awards, which reflects no adjustment to the fair value of a share for the likelihood of the IPO, is \$100 million.

No compensation cost is recognized during the three-year service period because the IPO is not deemed probable. In Year 5, the period that includes the IPO, ABC would recognize compensation cost equal to the entire amount of the grant-date fair value of \$100 million.

If the IPO does not occur by Year 10, then no compensation cost would be recognized for these awards.

If the IPO were to occur at the end of Year 2, ABC would record \$66.6 million of compensation cost in Year 2 as a cumulative adjustment; the remaining \$33.4 million of compensation cost would be recorded in Year 3.

Example 4.29: Award Includes a Performance Condition Based on EBITDA Targets

On January 1, 20X6, ABC Corp. grants 100,000 RSUs each to five employees that include a three-year service condition and a performance condition based on the ABC's EBITDA at the end of Year 3. If the EBITDA target is not achieved, then the RSUs will expire worthless. However, if an elevated EBITDA threshold is achieved, each employee will receive 150,000 RSUs. The grant-date fair value of an RSU, which reflects no adjustment to the fair value of a share for the likelihood of meeting the condition, is \$10.

Under the terms of the plan, employees who become eligible to retire during the three-year service period are entitled to receive the same awards they would have earned as if they had remained employed throughout the three-year period. Two of the five employees who received awards are retirement-eligible at the grant date ("Group 1"). For those two employees there is no future service condition. Two other employees will become retirement eligible two years after the grant date ("Group 2"); accordingly, those two employees must provide two years of service. One employee will not be retirement eligible by the end of the three-year period ("Group 3"). There are no expected or actual forfeitures. Each reporting period, ABC considers the probability of achieving the EBITDA target. The best estimate at the end of Years 1 and 2 is that the lower EBITDA target will be achieved. During Year 3 ABC estimates that the elevated EBITDA level will be achieved and that is the final result. Therefore, all five employees receive 150,000 awards.

| Year | Group 1 | Group 2 | Group 3 | Total |
|---------------------------------------|--------------------------|------------------------|----------------------|------------------|
| 20X6 | \$2,000,000 ¹ | 1,000,000 ² | 333,333 ³ | 3,333,333 |
| 20X7 | — | 1,000,000 ² | 333,333 ³ | 1,333,333 |
| 20X8 | — | — | 333,334 ³ | 333,334 |
| 20X8 (true-up) ⁴ | 1,000,000 | 1,000,000 | 500,000 | 2,500,000 |
| Compensation cost for the year | \$3,000,000 | 3,000,000 | 1,500,000 | 7,500,000 |

¹ For the two employees in Group 1, who are immediately retirement eligible, ABC Corp. estimates a grant-date fair value of the awards at \$2 million (100,000 awards × 2 employees × \$10) and recognizes the full compensation cost on the grant date.

² For the two employees in Group 2, who are retirement eligible in Year 2, ABC Corp. estimates a grant-date fair value of \$2 million (100,000 awards × 2 employees × \$10) and recognizes the compensation cost ratably over the two-year service period.

³ For the fifth employee in Group 3, ABC Corp. estimates a grant date fair value of \$1,000,000, which it recognizes ratably over the three-year service period.

⁴ In 20X8, the final outcome is that the maximum level of EBITDA is achieved, and ABC recognizes incremental compensation cost for the 150,000 RSUs that actually vest for each of the five employees. (150,000 awards × 5 employees × \$10, less the \$5 million recognized previously).

4.101 For share-based payment awards that contain performance conditions that are based on IPOs, change in control or other liquidity events, and a market condition (i.e., on IPO, stock price must achieve a specified level), the market condition is incorporated into the valuation of the share options resulting in a discount from the value that would be estimated for a similar award without the market condition. Because the award contains an *and* condition (i.e., achievement of both the market and the performance condition) and the performance condition is not deemed to be probable of occurrence, the resulting grant-date fair value of the award is recognized only if the liquidity event occurs. As discussed in Paragraph 4.099, the performance condition becomes probable of achievement on consummation of the transaction or occurrence of the event. When the outcome of the performance condition is resolved, the requisite service period for the awards has been rendered and the grant-date fair value of the awards should be recognized. This is true even if the market condition is not met and no awards are earned, because the risks associated with achieving the market condition were incorporated into the grant-date fair value measurement. See ASC paragraphs 718-20-55-62 through 55-67 for an illustration of the accounting for a share-based payment award with market conditions and performance conditions.

4.102 ASC Topic 718 does not provide specific guidance on the recognition of compensation cost when the performance condition is initially deemed to be probable of achievement and subsequently is no longer considered to be probable of achievement. As a result, there is mixed practice. We believe that compensation cost previously recognized because a performance condition is deemed to be probable of achievement would not be reversed unless the condition is subsequently determined to be *improbable*

of achievement. If the performance condition is no longer probable of achievement but a determination has not yet been made that the performance condition is improbable of achievement, the company should discontinue the recognition of compensation cost but should not reverse compensation cost previously recognized. If subsequently the performance condition is deemed to be improbable of achievement, the compensation cost previously recorded would be reversed. There also is some practice that once the performance condition is not probable of being achieved any previously recognized compensation cost is immediately reversed. If achievement of the performance condition later becomes probable, a cumulative effect adjustment of compensation cost is then recorded. If this method is followed, there could be frequent cumulative positive and negative adjustments if an award has a performance condition that is *close* to being probable and a different judgment is reached at different period ends.

Example 4.30: Changes in the Likelihood of Achieving a Performance Condition

On January 1, 20X5, ABC Corp. grants 25,000 share options to its Vice President of Marketing that vest if cumulative sales of Product X (a new product) reach \$500 million within five years. The grant-date fair value of the award is \$10 per share option. Based on its forecast, ABC believes that it is probable that the sales target will be met during 20X9. Based on this assessment, the implicit service period of the performance condition is five years.

During 20X5 and 20X6, the sales target is assessed as probable of achievement in 20X9, and ABC recognizes compensation cost of \$50,000 per year.

During 20X7, a competitor launches a similar product. As a result of introduction of the competitive product, ABC believes the probability of achieving the sales target by the end of 20X9 is less than probable but is still more than improbable.

Policy 1. Based on the revised probability assessment, during 20X7, ABC could elect an accounting policy whereby it would not recognize additional compensation cost. However, because the sales target is not deemed to be improbable of achievement, it would not reverse any of the previously recognized compensation cost.

Based on subsequent changes in its forecast, if the performance condition is reassessed as probable in 20X8 or 20X9, ABC will recognize additional compensation cost, based on the proportionate amount of requisite service that has been rendered to date. If in 20X8 or 20X9 the performance condition is improbable of achievement, the \$100,000 of compensation cost previously recognized would be reversed in the period that the assessment is made that the performance condition is improbable of achievement. If instead the forecast by the end of 20X8 indicates that achievement of the performance condition is again probable, ABC would record a catch-up adjustment of \$100,000 of compensation cost in 20X8 (the period of the change in judgment) for the compensation attributable to 2007 and 2008 and recognize \$50,000 of compensation cost in 20X9.

Policy 2. ABC also could elect an accounting policy whereby in 20X7 it would reverse the previously recorded compensation cost of \$100,000. If the award ultimately is not achieved, then there would be no additional entries for ABC to record. However, if the forecast at the end of 20X8 indicates that achievement of the performance condition is again probable, ABC would record a catch-up adjustment for \$200,000 of compensation cost in 20X8 (the period of the change in judgment) for compensation attributable to 2005-2008 and recognize \$50,000 of compensation cost in 20X9.

ATTRIBUTION FOR NONEMPLOYEE AWARDS WITH PERFORMANCE CONDITIONS

4.103 The definition of *performance condition* in Topic 718 after adoption of ASU 2018-07 is the same for employee and nonemployee awards. That is, the principles on how to account for various aspects of employee awards with performance conditions (i.e., accounting for these awards using a probability-based approach) are the same for nonemployee awards. This is because, in general, ASU 2018-07 eliminated the separate accounting models for nonemployee share-based payment awards, with the exception of compensation cost attribution and certain inputs to the valuation of stock options, as discussed at Paragraphs 4.086a and 2.013, respectively. ASU 2018-07 amended the definition of a performance condition to specifically state if a performance target is by reference to the grantee's performance, it must be related to the grantor's own operations or activities and in accordance with the terms of the award. As a result, when considering nonemployee awards, the delivery of goods or services themselves by nonemployees would not be considered performance conditions under Topic 718; rather, they are considered service conditions. Performance conditions for nonemployee awards would result from something more than just the delivery of goods or services (e.g., EPS targets or revenue growth rates of the grantor).

4.103a Similar to employee awards, we believe for awards that vest on an IPO, change in control or other liquidity events, the guidance in ASC paragraphs 805-20-55-50 and 55-51 is relevant for determining when the performance condition becomes probable of achievement.

4.104 – 4.107 Not used.

ATTRIBUTION PERIOD FOR EMPLOYEE AWARDS WITH MARKET CONDITIONS

4.108 As discussed in Paragraph 4.071, if an award containing a market condition does not have an explicit service period (e.g., the award becomes exercisable when the entity's closing stock price exceeds \$50 per share for 10 consecutive trading days), the employee's requisite service period is derived from the valuation model used to determine fair value of the award (refer to Section 2, *Measurement of Awards*). Once the employee's requisite service period is derived from the valuation model, it would *not* be subsequently revised unless either: (1) the market condition is satisfied prior to the end of

the initially estimated derived service period, or (2) an award would vest upon satisfaction of a performance or service condition that becomes probable of achievement before the end of the initially estimated derived service period. ASC paragraph 718-10-55-77

Example 4.31: Award Containing a Market Condition

On January 1, 20X5, ABC Corp. grants its CEO 50,000 share options with an exercise price of \$10 per share option and a contractual term of seven years. The share options only become exercisable if ABC's share price achieves a closing price of \$20 per share for 10 consecutive trading days. ABC's accounting policy is to account for forfeitures as they occur.

Background

| | |
|---|----------------------|
| Share options granted | 50,000 share options |
| Derived service period (see below) | 4 years |
| Grant-date fair value of share options based on 4-year derived service period | \$4 per share option |

Because there is no explicit service period stated in the award, a derived service period is determined based on the median path of a path-dependent option pricing model on which the market condition is expected to be satisfied. Based on the lattice option-pricing model used by ABC, its share price is projected to achieve the market condition over a four-year time period. As a result, compensation cost will be recognized over the four-year derived service period. When the requisite service period is derived based on a market condition, it is not subsequently adjusted regardless of the subsequent performance of the company's stock price unless the market condition is satisfied sooner than four years.

Assuming the CEO is employed through the end of the four-year derived service period (Scenario 1), compensation cost would not be reversed even if the market condition is never achieved and the award does not become exercisable, because the CEO has provided the requisite service for the award.

If the market condition were met during Year 3, which is before the end of the four-year derived service period (Scenario 2), any remaining unrecognized compensation cost would be immediately recognized.

Assuming the market condition had not yet been satisfied, if the CEO left the company during Year 4 before the completion of the derived service period (Scenario 3), any compensation cost previously recognized would be reversed.

| | | |
|----------------------------------|---------------------------------|-----------|
| Total compensation cost of award | $50,000 \times \$4 =$ | \$200,000 |
| Annual compensation cost | $\$200,000 / 4 \text{ years} =$ | \$ 50,000 |

| Compensation Cost Recognized | Scenario 1 | Scenario 2 | Scenario 3 |
|-------------------------------------|-------------------|----------------|------------|
| 20X5 | \$ 50,000 | 50,000 | 50,000 |
| 20X6 | 50,000 | 50,000 | 50,000 |
| 20X7 | 50,000 | 100,000 | 50,000 |
| 20X8 | 50,000 | — | (150,000) |
| Cumulative compensation cost | \$ 200,000 | 200,000 | 0 |

Example 4.31a: Recognition of Awards with Different Market Conditions at Different Dates

A company issues an award that vests if either: (1) the share price is higher than a specified price at one future date (the Initial Date) or (2) the share price is higher than a different specified price at a different future date (the Subsequent Date). These are both market conditions that affect the fair value of the award.

Q. How should a company recognize compensation cost for a share-based payment award with two different market conditions that are evaluated at two different dates?

A. Because the award vests on achieving either market condition, it is not clear how the award should be valued and compensation cost recognized. While there may be other acceptable approaches for this type of award, one acceptable way to account for this award is to calculate the fair value of an award that contains only the Initial Date market condition (i.e., as if the Subsequent Date market condition did not exist). Separately, calculate the fair value of an award that will vest if the Subsequent Date market condition is achieved. The higher of these two values is the total compensation cost that should be recognized for the award if the requisite service is rendered (regardless of whether either market condition is achieved). The attribution of compensation cost would depend on the facts and circumstances:

Scenario 1 - The grant date fair value of the Initial Date award is lower. Recognize compensation cost for the fair value of the Initial Date award over the period from the grant date to the Initial Date, and the incremental compensation cost for the Subsequent Date award, also over the period from the grant date to the Subsequent Date. This would result in some attribution of both awards during the overlapping periods. If the Initial Date market condition is met, the award is vested and, accordingly, the remaining unrecognized compensation cost for the incremental value of the Subsequent Date award would be accelerated. If the Initial Date market condition is not met, attribution for the Subsequent Date award would continue over the incremental requisite service period.

Scenario 2 - The grant date fair value of the Initial Date award is higher. Record the compensation cost for the Initial Date award over the period between the grant date and the Initial Date. Regardless of whether the Initial Date award is earned, no remaining

compensation cost would be attributed to the period from the Initial Date to the Subsequent Date.

Example 4.31b: Award Containing a Market Condition with an Explicit Service Period and a Change in Estimated Forfeitures

| | |
|--|--|
| Share options granted | 26,250 share options |
| Vesting conditions | Vesting occurs if Company A's shares outperform the S&P 500 by 5% over a 3-year period beginning on the grant date |
| Entity elects a policy to estimate the number of forfeitures – Estimated forfeiture rate | 8% |
| Grant-date fair value | \$8 per share option |
| Year 2 estimated forfeitures | 15% |
| Year 3 actual forfeitures | 15% |

At the end of the three-year period, Company A's stock has not outperformed the S&P 500 by 5%. As a result, no awards are exercisable. Compensation cost should not be reversed for the employees who achieved the requisite service period of three years. Years' 2 and 3 compensation cost is the difference between the total compensation expense to be recognized using a 15% forfeiture rate and total compensation expense recognized in Year 1, as follows:

| | |
|--|--|
| Total estimated compensation cost of award at grant date | $(26,250 \text{ share options} \times .92) \times \$8 = \$193,200$ |
| Compensation cost recognized in Year 1 | $\$193,200 / 3 \text{ years} = \$64,400$ |
| Compensation cost recognized in Years 2 and 3 | |
| Total compensation cost after forfeiture rate is estimated to be 15% | $(26,250 \text{ share options} \times .85) \times \$8 = \$178,500$ |
| Compensation cost not yet recognized | $\$178,500 - 64,400 = \$114,100$ |
| Compensation cost to be recognized in Years 2 and 3 | $\$114,100 / 2 \text{ Years} = \$57,050$ |

ATTRIBUTION FOR NONEMPLOYEE AWARDS WITH MARKET CONDITIONS

4.108a As discussed at Paragraph 4.070, unlike performance and service conditions that affect vesting, the effect of market conditions on nonemployee awards is reflected in estimating the grant-date fair value of the award. Similar to employee awards, a market

condition is not considered to be a vesting condition, and an award is not deemed to be forfeited solely because a market condition is not satisfied. Also, for nonemployee awards with market conditions, the nonemployee vesting period may be either stated explicitly or derived from the valuation technique used to estimate the grant-date fair value of the award.

4.108b Further, as discussed at Paragraph 4.073, if the exercisability of a nonemployee award depends on achieving a market condition, recognized compensation cost is not reversed if an award does not become exercisable because the market condition is not achieved as long as the grantee delivers the promised goods or renders the services. However, in our experience, nonemployee awards with market conditions are not common.

4.108c For a nonemployee award with a market condition, previously recognized compensation cost would be reversed only if the nonemployee did not deliver the promised goods or services, unless the market condition is satisfied before the end of the nonemployee's vesting period. In that case, unrecognized compensation cost is recognized at the time the market condition is satisfied. ASC paragraph 718-10-30-27 and 718-10-55-61

ATTRIBUTION PERIOD FOR EMPLOYEE AWARDS REQUIRING SATISFACTION OF SERVICE OR PERFORMANCE CONDITIONS

4.109 Awards that have a combination of service and performance conditions may contain multiple explicit or implicit service periods. If vesting is based on satisfying *either* the service *or* the performance condition, the initial determination of the employee's requisite service period is the *shorter* of the explicit service period for the service condition or the explicit or implicit service period for the performance condition, as long as the performance condition is probable of achievement. For example, if an award with an explicit service condition contains an accelerated vesting provision based on a performance condition that is probable of achievement, the employee's requisite service period would be the period over which the performance condition is expected to be satisfied (the shorter of the two periods), generally. (ASC paragraphs 718-10-55-72 and 55-73) In these circumstances, compensation cost attribution for awards to nonemployees may be the same as or different than employee awards. That is because an entity is required to recognize compensation cost for nonemployee awards in the same manner as if the entity had paid cash.

4.110 The Time Accelerated Restricted Stock Award Plan (TARSAP) is a type of employee share-based compensation arrangement that possesses service and performance or service and market conditions. Under a TARSAP, nonvested stock is awarded to the participant. These plans generally provide for the award to vest based on the passage of time (e.g., 20% per year for five years), with a provision for acceleration of vesting if certain performance or market criteria are met. In this situation, the achievement of the performance or market condition affects the timing of vesting or exercisability of the award, not the quantity of awards that vest or become exercisable. A TARSAP-type arrangement can also be used for determining vesting or exercisability of share options.

For example, a company can grant a fixed number of *at-the-money* share options that vest relatively early in the life of the awards but have delayed exercisability (without an ongoing service requirement) for seven years. The plan may provide for acceleration of the delayed exercisability if certain performance or market criteria are met earlier. Refer to the flowchart in Paragraph 4.076 to determine the employee's requisite service period for these awards.

4.111 In situations where an employee award contains a service condition with a performance condition that can accelerate vesting, if the performance condition were deemed to be not probable of achievement, the initial employee's requisite service period would be the explicit service period of the award. However, if the performance condition becomes probable of achievement prior to the completion of the explicit service period, the employee's requisite service period would become the shorter implicit service period associated with the probable achievement of the performance condition. Refer to Paragraph 4.097 for guidance about changes in the outcome of service and performance conditions. ASC paragraph 718-10-55-75

Q&A 4.19: Employee's Requisite Service Period for an Award with a Performance-Based Acceleration Clause and a Service Condition

Q. ABC Corp. grants 100,000 share options that vest at the end of five years of service. The share options also vest when ABC releases the next version of its software product. ABC estimates that the next version of its software product will be released within the next three years. ABC's accounting policy is to account for forfeitures as they occur. What is the employee's requisite service period of the award?

A. The award contains an explicit service period of five years related to the service condition and an implicit service period of three years related to the performance condition. If it were probable that the performance condition will be met, the requisite service period would be three years.

If it were not probable that the performance condition will be met before the five-year explicit service period's completion, compensation cost would be recognized over a five-year service period. However, in that circumstance, if it subsequently becomes probable that the performance condition will be met before the end of the five-year explicit service period (e.g., during Year 3 the performance condition is probable of achievement during Year 4), the guidance in Paragraph 4.097 for changes in estimates of the requisite service period would be followed. The acceleration of vesting does not affect the grant-date fair value of the award used to recognize compensation cost. However, the change in the requisite service period could affect ABC's estimate of forfeitures if ABC's accounting policy is to estimate forfeitures in determining the amount of compensation cost to recognize each period

Example 4.32: Change in Employee's Requisite Service Period Based on Accelerated Vesting—Grant of Nonvested Shares

Background

| | |
|--|---|
| Nonvested shares granted | 50,000 shares |
| Vesting schedule | 100% at the end of Year 5. However, the shares vest when Product X's sales exceed \$50 million per year |
| Probability assessment at date of grant related to performance condition | Not probable |
| Grant-date fair value (market price of shares) | \$10 |
| Change in probability assessment | At the beginning of Year 3, annual sales are now probable of exceeding \$50 million in Year 4 |
| Total compensation cost of award at grant date | $50,000 \times \$10 = \$500,000$ |
| Total compensation recognized in Years 1 and 2 | $\$500,000 \div 5 = \$100,000$ per year |

Compensation cost recognized in Years 3 and 4:

| | | |
|--|--------------------------------------|-------------------------|
| Total compensation cost | | \$500,000 |
| Cumulative compensation cost recognized through Year 2 | $\$100,000 \times 2 \text{ years} =$ | <u>\$(200,000)</u> |
| Unrecognized compensation cost at beginning of Year 3 | | <u>\$300,000</u> |
| Compensation cost recognized per year in Years 3 and 4 | | <u><u>\$150,000</u></u> |

Example 4.33: Change in Employee's Requisite Service Period Based on Accelerated Vesting—Grant of Nonvested Shares

ABC Corp. grants to certain of its employees 5,000 nonvested shares. The nonvested shares have fair value on the grant date of \$10 each and cliff vest after three years if ABC meets a performance condition, or after five years of service if the performance condition is not met.

At the date of grant, ABC assesses the likelihood of the performance condition being met as more likely than not but not probable. ABC's accounting policy is to estimate the number of forfeitures in determining the amount of compensation cost to be recognized in each period. Accordingly, ABC initially estimates that employees holding 20% of the nonvested shares will terminate and therefore forfeit their shares.

As of the beginning of Year 2, no forfeitures have occurred and ABC determines that the performance condition is probable of achievement. As a result, ABC revises its estimate of expected forfeitures to 10%.

In Year 1, compensation cost of \$8,000 ($5,000 \times \$10 \times 80\% \times 1/5$) is recognized because the performance condition is not probable of achievement and, therefore, the requisite service period is the explicit service period for the service condition.

In Year 2 as a result of the performance condition being deemed probable of achievement and the resulting change in the estimated rate of forfeitures, ABC expects to recognize total compensation cost of \$45,000 ($5,000 \times \$10 \times 90\%$) over the requisite service period of the award. Because the estimate of total compensation cost has changed from the original estimate of \$40,000 ($5,000 \times \$10 \times 80\%$), ABC should recognize compensation cost in Year 2 using a cumulative effect computation. Therefore, by the end of Year 2, cumulative compensation cost to recognize is \$30,000 ($\$45,000 \times 2 \text{ years} / 3 \text{ years}$). Compensation cost previously recognized is \$8,000 (Year 1 compensation cost). Therefore, the compensation cost to recognize in Year 2 is \$22,000 ($\$30,000 - \$8,000$). Assuming the performance target is achieved in Year 3 and no other adjustments to the forfeiture rate are needed (i.e., actual forfeitures equal 10%), compensation cost in Year 3 would be \$15,000.

An alternative recognition method would be to recognize the effects of the change in the estimated forfeitures as an adjustment to the cumulative compensation cost-to-date, and to recognize the remaining unrecognized compensation cost prospectively over the revised requisite service period.

| | |
|---|----------------------|
| Compensation cost cumulative adjustment to recognize at the beginning of Year 2 | \$5,000 ¹ |
| Compensation cost to recognize in Year 2 | 16,000 ² |
| Compensation cost to recognize in Year 3 | 16,000 ² |

¹ \$45,000 - \$40,000

² $(\$45,000 - 8,000 - 5,000) / 2$

Q&A 4.20: Vesting Based on an IPO or Change of Control

Q. An award that vests after four years of service contains an acceleration clause that vests the award on an IPO or change of control. Would an IPO or change of control condition that accelerates vesting be considered probable for estimating an implicit service period?

A. No. Given the level of uncertainty of an IPO or change in control and that such events are, at least partly, outside the control of the entity, vesting based on an IPO or change of control performance condition is not probable of achievement prior to the consummation of such a transaction. As a result, the employee's requisite service period would be the

four-year explicit service period of the award. If an IPO or change of control occurred before completion of the explicit service period causing the accelerated vesting of the award, any remaining unrecognized compensation cost would be recognized in the period the event occurred.

ATTRIBUTION PERIOD FOR EMPLOYEE AWARDS REQUIRING SATISFACTION OF SERVICE AND PERFORMANCE CONDITIONS

4.112 If vesting is based on satisfying *both* service *and* performance conditions and the performance condition is probable of achievement, the initial estimate of the requisite service period is the *longer* of the explicit or implicit service period. If vesting is based on satisfying *both* service *and* performance conditions and the performance condition is not considered probable of achievement, no compensation cost is recognized until such time as the performance condition is considered probable of achievement or, in some circumstances, the performance condition is met. In these circumstances, compensation cost attribution for awards to nonemployees may be the same as or different than employee awards. That is because an entity is required to recognize compensation cost for nonemployee awards in the same manner as if the entity had paid cash. ASC paragraphs 718-10-55-72 and 55-73

Q&A 4.21: Requisite Service Period for an Award with Both a Service and Performance Condition (Implicit Service Period Longer)

Q. ABC Corp. grants 500,000 nonvested shares to employees that vest upon (1) the completion of two years of service, *and* (2) the design of a prototype of ABC's next generation memory chip. ABC estimates that it is probable that the design of the prototype of its memory chip will be completed approximately three years from the date of grant. What is the requisite service period of the award?

A. The award contains an explicit service period of two years related to the service condition and an implicit service period of three years related to the performance condition. Assuming that it is probable that the performance condition will be met, compensation cost would be recognized over the three-year implicit service period associated with the performance condition.

Q&A 4.22: Requisite Service Period for an Award with Both a Service and Performance Condition (Explicit Service Period Longer)

Q. Assume the same information as in Q&A 4.21, except that ABC Corp. determines that it is probable that the design of the prototype will be completed in one year. What is the requisite service period of the award?

A. If it were probable that the design of the prototype of the memory chip will be completed within one year, compensation cost will be recognized over the two-year explicit service period related to the service condition.

Q&A 4.23: Requisite Service Period for an Award with Both a Service and Performance Condition (Performance Condition Not Probable of Achievement)

Q. Assume the same information as in Q&A 4.21, except that ABC Corp. determines that it is not probable that the design of the prototype would be completed. What is the requisite service period of the award?

A. Because the performance condition is not probable of achievement, no compensation cost would be recognized until the performance condition becomes probable of achievement. If the performance condition later becomes probable of achievement, the requisite service period would be determined at that time.

ATTRIBUTION PERIOD FOR AWARDS REQUIRING SATISFACTION OF SERVICE OR PERFORMANCE CONDITIONS AND MARKET CONDITIONS

4.113 Vesting or exercisability may be based on satisfying two or more types of conditions (e.g., a service *and* a market condition) or may be based on satisfying one of two or more types of conditions (e.g., a performance *or* a market condition). Regardless of the number and type of conditions that are required to be satisfied, the existence of a market condition requires the recognition of compensation cost if the goods are delivered or the services are rendered, even if the market condition is never satisfied. In these circumstances, compensation cost attribution for awards to nonemployees may be the same as or different than employee awards. That is because an entity is required to recognize compensation cost for nonemployee awards in the same manner as if the entity had paid cash. ASC paragraphs 718-10-55-62 and 55-63

4.114 If exercisability or vesting is based on satisfying either (a) a market condition, or (b) a service or a performance condition that is probable of achievement (i.e., a performance condition that is not probable of being met is not considered in this evaluation), the initial estimate of the employee's requisite service period is the shorter of the explicit, implicit, or derived service periods.

Example 4.34: Exercisability or Vesting Dependent on Achievement of *Either* a Market or Service Condition

On January 1, 20X5, ABC Corp. grants to a member of management 400,000 share options with an exercise price of \$10 per share and a contractual term of 10 years. Exercisability and vesting of the share options will occur upon the *earlier* of (a) ABC's closing share price being above \$20 per share for 10 consecutive trading days, or (b) the completion of five years of service.

Background

| | |
|--|-----------------------|
| Share options granted | 400,000 share options |
| Derived service period | 3 years |
| Explicit service period | 5 years |
| Requisite service period (shorter of derived or explicit service periods) | 3 years |
| Grant-date fair value per share option, based on the requisite service period of three years | \$3 |

The award contains a service condition with an explicit service period of five years and a market condition with a derived service period of three years, which was derived from the lattice model's results. Because the award's exercisability or vesting is based on meeting *either* (1) a market condition, *or* (2) a service condition, the requisite service period is the shorter of the explicit service period or the derived service period. In this example, the requisite service period would be the derived service period of three years. As a result, compensation cost would be measured based on the grant-date fair value of the award determined using the three-year derived service period and recognized over the three-year derived service period.

If the market condition is satisfied in July 20X6 (Scenario 1), ABC would immediately recognize the remaining unrecognized compensation cost during 20X6, because no further service is required to earn the award.

If the employee provided service through the end of the derived service period (Scenario 2), compensation cost would not be reversed even if the market condition were never achieved.

If the employee was terminated in March 20X7, which is before the completion of the derived service period (Scenario 3), then any previously recognized compensation cost would be reversed.

If the employee departed from the company in April 20X8 with the market condition not achieved (Scenario 4), compensation cost would not be reversed because the requisite service had been provided.

Grant-date fair value per share option,
based on the requisite service period –
\$3 per share option

| | | |
|----------------------------------|-----------------------------------|-------------|
| Total compensation cost of award | $400,000 \times \$3 =$ | \$1,200,000 |
| Annual compensation cost | $\$1,200,000 / 3 \text{ years} =$ | \$400,000 |

| Compensation cost recognized | | | |
|------------------------------|--------------------|------------------|------------|
| | Scenario 1 | Scenario 2 | Scenario 3 |
| 20X5 | \$ 400,000 | 400,000 | 400,000 |
| 20X6 | 800,000 | 400,000 | 400,000 |
| 20X7 | — | 400,000 | (800,000) |
| Cumulative compensation cost | <u>\$1,200,000</u> | <u>1,200,000</u> | <u>0</u> |

4.115 If exercisability or vesting is based on satisfying *both* (1) a market condition, *and* (2) a service or a performance condition that is probable of achievement (i.e., a performance condition that is not probable of being met is not considered in this evaluation), the initial estimate of the employee's requisite service period is the *longer* of the explicit, implicit, or derived service period.

Example 4.35: Exercisability or Vesting Dependent on Both a Market Condition and a Service Condition—Derived Service Period Is Shorter Than Explicit Service Period

On January 1, 20X4, ABC Corp. grants its CEO 100,000 share options with an exercise price of \$20 per share and a contractual term of 10 years. Exercisability and vesting of the share options are based on *both* (a) ABC's closing share price exceeding \$40 per share for 10 consecutive trading days *and* (b) the completion of four years of service. The award contains a service condition with an explicit service period of four years and a market condition with a derived service period.

If the derived service period for the market condition were three years, the requisite service period would be four years because the four-year explicit service period related to the service condition is longer than the three-year derived service period of the market condition.

If the market condition is achieved in year 3 and the CEO rendered the requisite service over the four-year service period of the award (Scenario 1), compensation cost would be recognized over the four-year service period.

If the CEO rendered the requisite service over the four-year service period of the award but the market condition is not achieved (Scenario 2), compensation cost would still be recognized over the four-year requisite service period. In this situation, the requisite service was provided and, therefore, compensation cost is recognized, even though the award never became exercisable.

If the CEO left ABC in July 20X6, which is prior to the completion of the four-year requisite service period (Scenario 3), any previously recognized compensation would be reversed because the requisite service was not provided by the CEO.

Grant-date fair value per share option,
based on four-year requisite service period
– \$3.50 per share option

Total compensation cost of award $100,000 \times \$3.50 = \$350,000$
Annual compensation cost $\$350,000 / 4 \text{ years} = \$87,500$

Compensation cost recognized

| | Scenario 1 | Scenario 2 | Scenario 3 |
|---------------------------------|-------------------|----------------|------------|
| 20X4 | \$ 87,500 | 87,500 | 87,500 |
| 20X5 | 87,500 | 87,500 | 87,500 |
| 20X6 | 87,500 | 87,500 | (175,000) |
| 20X7 | 87,500 | 87,500 | — |
| Cumulative compensation cost | <u>\$ 350,000</u> | <u>350,000</u> | <u>0</u> |

Example 4.35a: Vesting or Exercisability Dependent on a Service Condition AND either a Market Condition OR a Performance Condition

Assume the same facts as in Example 4.35, except that the vesting terms are based on *both* (a) the completion of four years of service and *one of the following two conditions* (b) ABC's closing share price exceeding \$40 per share for 10 consecutive trading days OR (c) ABC's pharmaceutical drug currently in development obtaining FDA approval.

In this case, to determine the grant-date fair value, the company would calculate the grant-date fair value separately for both the achievement of the market condition and the performance condition. The company calculates the grant date fair value of \$3.50 assuming the market condition is achieved, and a grant date fair value of \$4.00 assuming the performance condition is achieved.

To determine the compensation cost to be recognized throughout the service period, the company would assess whether it is probable that the performance condition will be achieved. If the company believes that it is not probable that the performance condition will be achieved, it recognizes compensation cost over the service period using the grant date fair value of \$3.50 per share. If the company believes that it is probable that the performance condition will be achieved, it recognizes compensation cost over the service period using the grant date fair value of \$4.00 per share.

Because of the market condition, the total compensation cost recognized would be a minimum of the \$3.50 per share regardless of whether achievement of the performance condition was considered probable. The probability of the performance condition being met needs to be assessed at each reporting period. If achievement of the performance condition is not probable at the grant date but becomes probable at a later reporting period date, additional compensation cost using the grant date fair value of \$4.00 per

share is recognized at that time, and over the remaining service period. For awards that are forfeited, however, compensation cost would not be recognized for employees who do not meet the service condition.

Example 4.36: Vesting or Exercisability Dependent on Both a Market Condition and a Service Condition (Derived Service Period Is Longer Than Explicit Service Period)

Assume the same facts as in Example 4.35 except that, based on the option pricing model, the derived service period for the market condition is six years. Therefore, the requisite service period would be six years, because it is longer than the four-year explicit service period related to the service condition. If the CEO rendered the requisite service over the six-year service period of the award but the market condition is never achieved (Scenario 1), compensation cost would be recognized over the six-year requisite service period because the CEO provided the requisite service.

If the market condition is achieved during 20X8 (Scenario 2), both the service condition and market condition would be met and any remaining unrecognized compensation would be immediately recognized.

If the market condition were achieved in 20X6, which is before the completion of the explicit service period of the service condition (Scenario 3), compensation cost would be recognized over the remaining explicit service period because the award would vest upon completion of the explicit service period.

If the CEO left ABC in 20X8 after completion of the four-year explicit service period but prior to the completion of the six-year requisite service period, the previously recognized compensation cost would be reversed unless the market condition had already been achieved (Scenario 4) because the CEO did not provide the requisite service.

| | | |
|--|---------------------------------|-----------|
| Grant-date fair value per share option, based on six-year derived service period | \$4.50 per share option | |
| Total compensation cost of award | $100,000 \times \$4.50 =$ | \$450,000 |
| Annual compensation cost | $\$450,000 / 6 \text{ years} =$ | \$75,000 |

| Compensation cost recognized | | | | |
|------------------------------|-------------------|----------------|----------------|------------|
| | Scenario 1 | Scenario 2 | Scenario 3 | Scenario 4 |
| 20X4 | \$ 75,000 | 75,000 | 75,000 | 75,000 |
| 20X5 | 75,000 | 75,000 | 75,000 | 75,000 |
| 20X6 | 75,000 | 75,000 | 75,000 | 75,000 |
| 20X7 | 75,000 | 75,000 | 150,000 | 75,000 |
| 20X8 | 75,000 | 150,000 | — | (300,000) |
| 20X9 | 75,000 | — | — | — |
| Cumulative compensation cost | \$ <u>450,000</u> | <u>450,000</u> | <u>450,000</u> | <u>0</u> |

Example 4.37: Vesting or Exercisability Dependent on Both a Market Condition and a Performance Condition for a Private Equity Investment

A leveraged buyout arrangement specifies that a targeted number of shares will be earned by the management group when a specified overall *realized* internal rate of return (IRR) for the private equity investors is reached. The *realized* IRR is measured on the occurrence of an IPO or a change in control.

In this instance, because the IRR is based on an overall return to private equity investors, the specified IRR is considered a market condition, similar to a total shareholder return measure. The probability of the specified overall internal rate of return being achieved will be incorporated into the grant-date fair value of the award, and will not determine whether or not the compensation cost is recognized.

The IPO or change in control is a performance condition. The performance condition is not incorporated into the grant-date fair value measure. Instead, the performance condition is included in the attribution of the award. Until the IPO or change in control becomes probable of occurrence, there would be no compensation cost recognized, and for a liquidity event, recognition of compensation cost is deferred until the liquidity event occurs.

The award would be equity-classified assuming that all other conditions for equity classification are met. Therefore, when the liquidity event occurs, compensation cost would be recognized based on the grant-date fair value measure (which incorporates the market condition). If the performance condition is initially achieved through an IPO, but because of poor economic conditions, the market condition is not met, the grant-date fair value of the award is still recognized as compensation cost because the performance condition is met.

ATTRIBUTION PERIOD FOR AWARDS REQUIRING SATISFACTION OF A COMBINATION OF A PERFORMANCE AND A MARKET CONDITION

4.116 Vesting and exercisability may be based on a combination of a performance condition and a market condition. For example, the number of awards that vest and become exercisable is determined by the combination of a return on equity (performance condition) and a total shareholder return (market condition).

4.117 ASC Topic 718 does not explicitly address how to value an award that requires satisfaction of a combination of a performance and a market condition. Performance or service conditions that only affect vesting are not considered in the grant-date fair value whereas market conditions are included in the grant-date fair value. In these circumstances, compensation cost attribution for awards to nonemployees may be the same as or different than employee awards. That is because an entity is required to recognize compensation cost for nonemployee awards in the same manner as if the entity had paid cash.

4.118 The first step to value such an award is to determine if the award can be separated into two awards or is to be accounted for as one award. This requires a thorough understanding of the interaction of the performance and market conditions. A payout matrix often is included in the grant information, and can be helpful in performing the analysis. A payout matrix also can be derived from a detailed analysis of the terms. In some cases, the entire award will be subject to performance and market conditions that both must be met. These awards will require complex valuation methodologies to determine the grant date fair value of the award. An illustration of this kind of award is shown in Example 4.38. In contrast, the share-based payment arrangement would be considered two awards if there is an identifiable number of shares that would vest based solely on the outcome of either the performance condition or the market condition, without regard to the other. If so, those are accounted for as separate awards following the appropriate guidance for awards with performance or market conditions. In some cases, a portion of the award vests only upon achievement of a performance condition and the remainder is subject to achieving both a performance condition and a market condition. In those cases, the portion of the award only subject to the performance condition is accounted for separately. The portion of the award that vests based on the combination of the outcome of the performance condition and the market condition is accounted for similar to the award described in Example 4.38. An illustration of this kind of award is shown in Example 4.38a.

Once separated, each component would be accounted for separately as an award with a performance condition and an award with a market condition, respectively. Awards, or parts of awards, that are based on an additive (an *and* condition) would not be separated and would be accounted for as one award. The following examples illustrate an approach to accounting for an additive award accounted for as a single award.

Example 4.38: Vesting and Exercisability Depending on a Combination of a Performance Condition and a Market Condition (One Award)

An entity issues 1,000 performance-based restricted units (PRU) to certain employees with a three-year service period. The number of PRUs that ultimately vest and become exercisable will be measured at the end of the three-year service period based on the combination of a revenue target (performance condition) and total shareholder return (TSR) (market condition) that work in combination such that to vest in any portion of the award, the minimum targets for both must be satisfied. The number of PRUs is determined by the payoff matrix below. For results between the specified thresholds and targets, the payoff is determined by interpolating between the specified amounts.

| | | Total Shareholder Return | | | |
|-------------------|--------|--------------------------|------|--------|------|
| | | <Min | Min | Target | Max |
| Revenue Target | Max | 0% | 120% | 160% | 240% |
| | Target | 0% | 75% | 100% | 150% |
| | Min | 0% | 30% | 40% | 60% |
| | <Min | 0% | 0% | 0% | 0% |

Grant-Date Fair Value. The grant-date fair value of the award would include an adjustment for the possible outcomes of the market condition (i.e., 0%, 75%, 100%, or 150% using the *Target Revenue Target* row to reflect the effect of only the market condition). For example, assume that the simulation yields a payout attributable to the market condition that is midway between the target of 100% and the maximum of 150%, which would result in a payout after interpolation of 125%. If the fair value of a share is \$25, the grant-date value of a PRU would be \$31.25 ($\$25 \times 125\%$).

Recognition of Compensation Cost. The shares expected to vest based solely on the outcome of the performance condition would be the amount that would be earned if the market condition were achieved at the target level – 0%, 40%, 100%, or 160%. The amount of compensation cost the entity would recognize over the requisite service period would be based on management’s best estimate of the achievement of the performance condition. If management estimates that the performance condition will be achieved at the minimum level, annual compensation cost would be \$4,167 ($[1,000 \text{ PRUs} \times \$31.25 \times 40\% \text{ performance target}] / 3 \text{ year service period}$).

If the ultimate outcome of the performance condition is higher or lower than the estimated level, the amount of compensation would be adjusted on a cumulative basis by substituting 0%, 100%, or 160% for the 40% used in the original estimate. However, if the ultimate outcome moves to a different outcome (e.g., minimum, less than minimum, or maximum) based on the final resolution of the market condition, that change would not be reflected in the compensation cost because this probability was incorporated into the grant-date fair value measurement of \$31.25.

For example, if the ultimate payout of the award is 240% because the maximum level was achieved for the revenue and TSR targets, the ultimate compensation cost would be

\$50,000 (1,000 PRUs \times \$31.25 \times 160%). Similarly, if the ultimate payout of the award is 75% because the target level was achieved for the revenue target but only the minimum level was achieved for the TSR target, the ultimate compensation cost would be \$31,250 (1,000 PRUs \times 31.25 \times 100%).

Example 4.38a: Vesting Depending on a Combination of a Performance Condition and a Market Condition (Two Awards)

An entity grants 1,000 RSUs subject to a targeted EPS goal (i.e., performance condition). The award specifies a range of possible outcomes starting with a minimum threshold amount to vest in 75% of the awards, a target amount to vest in 100% of the awards, and a maximum amount to earn 200% of the awards. In addition, a market limiting cap, which represents a market condition, reduces the payout under the target and maximum threshold performance condition by 20% if the company's TSR is low relative to the TSR of its peers. There is no market limiting cap if the minimum threshold performance conditions are met.

In Example 4.38, the number of awards that ultimately vest is based on the combination of a revenue target (performance condition) and total shareholder return (TSR) (market condition) that work in combination such that to vest in any portion of the award, the minimum targets for both must be satisfied.

However, in this example, there is an identifiable number of shares that vest based solely on the outcome of a performance condition (i.e., 750 awards), regardless of the TSR outcome. Those 750 RSUs would be accounted for separately based on the grant date fair value of the entity's shares. The remaining awards that vest are based on the combination of the outcome of the performance condition and the market limiting cap. The outcome for that portion of the award can range from 1,000 to 2,000 shares if both the performance condition is met at various levels and the TSR condition is met. If the TSR condition is not met but the performance condition is, the range could be from 800 to 1,600 shares. For this portion of the award, the combination of outcomes would be subject to complex valuation methodologies to determine the grant date fair value.

Example 4.38b: Vesting and Exercisability of Awards with a Market Condition and an Implied Performance Condition

ABC Corp. issues performance-based restricted units to certain members of management with a five-year service period. For the units to vest and become exercisable, the following Internal Rate of Return (IRR) targets must be met:

- Annual compounded IRR on the grantor's equity investment of at least 15% per annum over the five-year period; if met the restrictions with respect to 30% of the units awarded not previously forfeited lapse, or

- Annual compounded IRR on the grantor's equity investment of at least 20% per annum over the five-year period; if met the restrictions with respect to an additional 30% of the awarded units not previously forfeited lapse (i.e., the restrictions lapse with respect to a total of 60% of the units awarded), or
- Annual compounded IRR on the grantor's equity investment at such time of at least 25% per annum over the five-year period; if met, the restrictions with respect to an additional 40% of the awarded units not previously forfeited lapse (i.e., the restrictions lapse with respect to a total of 100% of the units awarded).

However, to meet an IRR target listed above, proceeds must be received by the grantor. Proceeds *must only* be received through a liquidity event, which could include a change in control or an IPO. Each of these liquidity events would allow for the grantor's investors to monetize all or a portion of their investment.

For these awards, the performance condition is not explicitly stated in the award. For example, these awards vest and become exercisable only if a market condition is satisfied (in this case, IRR is a market condition), but also an event that meets the definition of a performance condition (e.g., liquidity event) needs to occur. That is, because achievement of the market condition requires a defined liquidity event to occur, and therefore the awards contain both a market and a performance condition. Judgment about the facts and circumstances is necessary to determine whether an implied performance condition exists.

Compensation costs for these awards would only be recognized once achievement of the implied performance condition (liquidity event) is probable. The market condition (IRR, in this case) is included in the measurement of the award. In addition, the liquidity event would not be considered probable until it occurs. Further, as this award contains a market condition, the probability of the market condition being achieved is considered when determining the grant-date fair value of the award using a simulation-based valuation approach, such as a Monte Carlo simulation approach. See discussion beginning at Paragraph 2.079.

SERVICE, PERFORMANCE, AND MARKET CONDITIONS THAT AFFECT FACTORS OTHER THAN VESTING OR EXERCISABILITY

4.119 Service, performance, and market conditions may affect factors that are used in measuring compensation cost. For example, the exercise price of an award may be reduced or the number of shares or share options under the award may change if a performance condition is met. Performance conditions that affect factors other than vesting or exercisability, such as exercise price, contractual term, number of shares or share options or other pertinent factors, are considered when estimating compensation cost. A grant-date fair value should be determined for each possible outcome. The compensation cost ultimately recognized is equal to the grant-date fair value of the award

based on the actual outcome of the performance condition. See Paragraph 2.078, Example 2.6, Paragraph 2.084, and Example 2.8 for more guidance on when there is a performance condition that affects factors other than vesting or exercisability. ASC paragraph 718-10-30-15

4.120 For awards subject to market conditions that affect factors other than vesting, all possible outcomes are reflected in the fair value of the awards on the grant date and recognized over the employee's requisite service period or nonemployee's vesting period. This is unlike the accounting for awards with service or performance conditions that affect factors other than vesting where separate grant-date fair values are determined. Because the market conditions (which may affect factors other than vesting) are deemed to be exercisability conditions rather than vesting conditions, they are incorporated into a single grant-date fair value measure. ASC paragraph 718-10-55-64

4.121 If an award includes only a market condition and there is no explicit service or vesting condition, the grant-date fair value of the award would reflect the likelihood that the market condition will be achieved. However, ASC Topic 718 does not specifically address situations where exercisability or vesting of an award is based on satisfying either (a) a service or performance condition or (b) a market condition. An issue arises as to whether the impact of the market condition should be reflected in estimating the grant-date fair value of the award. The Statement 123(R) Resource Group, when discussing employee awards, concluded that because the employee will retain the award based on the achievement of the service or performance vesting condition even if the market condition is not achieved, the fair value of a *share option* award would be an amount that is between the grant-date fair value of the award with the market condition and without the market condition. The valuation should reflect the market condition, but also the likelihood that an employee would vest in the award based on service when the market condition is not achieved, thereby resulting in a higher value for the award than a similar award with only the market condition. However, if the award is a grant of *nonvested stock* that vests on satisfying either a market condition or a service condition, the Statement 123(R) Resource Group concluded that the nonvested stock would be valued at the fair value of the underlying stock on the grant date (i.e., there would be no valuation *haircut* related to the market condition). Additionally, for either award, to determine the employee's requisite service period the entity would need to use a lattice model or simulation to determine the derived service period associated with the market condition. The employee's requisite service period would be the shorter of the derived service period and the explicit service period related to the service or performance condition. Additional accounting guidance on the impact of market conditions on the grant-date fair value is discussed in Paragraphs 2.079 and 2.135. While the Statement 123(R) Resource Group discussed only employee awards, we believe the valuation considerations would equally apply to a nonemployee award with the same terms. However, given the different attribution approaches for nonemployee and employee awards, the vesting period consideration for the nonemployee awards could be different. See Paragraph 4.086a.

Example 4.39: Performance Condition That Affects the Number of Awards

ABC Corp. grants to each of its 20 regional sales managers 10,000 share options. The share options have a 10-year contractual term and an exercise price of \$8, which equals the market price of ABC's shares on the date of grant. The share options only vest if the market share of ABC's new product is 20% at the end of three years. However, if the market share exceeds 30% at the end of three years, each of the regional sales managers will receive 25,000 share options. At the date of grant, ABC believes that the 20% market share is probable of achievement. ABC believes the 30% market share is not probable of achievement.

Background

| | | |
|--|--|-----------------------|
| Share options granted (based on market share of 20%) | $10,000 \times 20$ regional sales managers = | 200,000 share options |
| Share options granted (based on market share of 30%) | $25,000 \times 20$ regional sales managers = | 500,000 share options |
| Probability assessment at date of grant: | | |
| Market share of 20% | Probable | |
| Market share of 30% | Not probable | |
| Grant-date fair value | \$3 per share option | |

The award has an explicit service period of three years. Based on its sales forecast, ABC determines at the grant date that it is probable that the market share of its new product will be above 20% at the end of three years, but it is not probable that it will achieve a 30% market share. Because ABC estimates that the performance condition at the 20% level is probable, it will begin to recognize compensation cost based on 200,000 share options (the number of share options if the 20% market share target is achieved). During the three-year requisite service period, ABC will continue to reassess the likelihood of achieving the two performance conditions.

If during the second year of the new product launch, the 30% market share is considered probable of achievement, compensation cost would be remeasured for the number of share options, as follows:

| | | |
|---|--------------------------------------|-------------------------|
| Initial total compensation cost of award | $200,000 \times \$3 =$ | \$600,000 |
| Compensation cost recognized in Year 1 | $600,000 / 3 =$ | \$200,000 |
| Revised compensation cost of award based on assessment that 30% market share is probable of achievement | $500,000 \times \$3 =$ | \$1,500,000 |
| Revised compensation cost in Year 2: | | |
| Revised compensation cost per year | $\$1,500,000 / 3 \text{ years} =$ | \$500,000 |
| Cumulative compensation cost to be recognized through Year 2 | $\$500,000 \times 2 \text{ years} =$ | \$1,000,000 |
| Compensation cost recognized in Year 1 | | <u>(200,000)</u> |
| Compensation cost to recognize in Year 2 | | <u>\$800,000</u> |
| Compensation cost to recognize in Year 3 | | <u><u>\$500,000</u></u> |

Because the change in the assessment of the performance condition affected the number of awards received and, therefore, the total amount of compensation, compensation cost was adjusted on a cumulative basis. At the end of the three-year service period, compensation cost is only recognized for the number of awards that ultimately vested based on the achievement of the market share target.

Example 4.40: Performance Condition That Affects Grant-Date Fair Value

ABC Corp. grants to each of its 20 regional sales managers 10,000 share options. The share options have a 10-year contractual term and an exercise price of \$8, which equals the market price of ABC's shares on the date of grant. The share options only vest if the market share of ABC's new product is 20% at the end of three years. However, if the market share exceeds 30% at the end of three years, the exercise price of the share options will be reduced to \$6 per share.

Background

| | |
|-----------------------|---|
| Share options granted | $10,000 \times 20$ regional sales managers = 200,000 share options |
|-----------------------|---|

Probability assessment at date of grant:

| | |
|---|-------------------------|
| Market share of 20% | Probable |
| Market share of 30% | Not probable |
| Grant-date fair value with exercise price of \$8 per share option | \$3.00 per share option |
| Grant-date fair value with exercise price of \$6 per share option | \$5.25 per share option |

The award has an explicit service period of three years. Based on its sales forecasts, ABC expects that, at the date of grant, it is probable that the market share of its new product will be above 20% at the end of three years, but it is not probable that it will achieve a 30% market share. Because ABC estimates that the performance condition at the 20% level is probable of achievement, it will begin to recognize compensation cost using a grant-date fair value of \$3 per share option. Although at the date of grant it is not probable that the 30% market share will be achieved, ABC will calculate grant-date fair value for that possible performance condition outcome. During the three-year requisite service period, ABC will continue to assess the probability of achieving each of the performance conditions.

If during the second year of the new product launch, the 30% market share were now considered probable of achievement, compensation cost would be recognized using the grant-date fair value based on the 30% outcome (\$6 exercise price and a grant-date fair value of \$5.25). The fair value for this possible outcome is computed at the grant date and not changed subsequently. Compensation cost is determined as follows:

| | | |
|--|--------------------------------------|-------------------------|
| Total compensation cost of award at grant date | $200,000 \times \$3 =$ | \$600,000 |
| Compensation cost recognized in Year 1 | $\$600,000 / 3 =$ | \$200,000 |
| Revised compensation cost in Year 2: | | |
| Revised compensation cost of award | $200,000 \times \$5.25 =$ | \$1,050,000 |
| Revised compensation cost per year | $\$1,050,000 / 3 \text{ years} =$ | \$350,000 |
| Cumulative compensation cost to recognize through Year 2 | $\$350,000 \times 2 \text{ years} =$ | \$700,000 |
| Compensation cost recognized in Year 1 | | <u>\$(200,000)</u> |
| Compensation cost to recognize in Year 2 | | <u><u>\$500,000</u></u> |
| Compensation cost to recognize in Year 3 | | \$350,000 |

Dividends on Awards

4.122 Under certain share-based payment arrangements, grantees are entitled to receive dividends paid on the underlying equity shares during the vesting period of an award. Dividends or dividend equivalents paid to grantees on the portion of an award of equity shares or other equity instruments that vest are charged to retained earnings. If grantees are not required to repay the dividends or dividend equivalents received when an award is forfeited, dividends or dividend equivalents paid on the awards that do not vest are recognized as compensation cost. If an entity's accounting policy is to estimate the number of awards expected to be forfeited in accordance with ASC paragraph 718-10-35-1D or 718-10-35-3, the estimate of compensation cost for dividends or dividend equivalents paid on share-based payment awards that are not expected to vest should be consistent with the entity's estimates of forfeitures. As the entity revises the estimated rate of forfeitures during the employee's requisite service period or nonemployee's vesting period, the effect of the change on the allocation of dividends paid between retained earnings and compensation cost is recognized in the current period. If an entity elects an accounting policy to account for forfeitures when they occur, the entity shall reclassify to compensation cost, in the period in which the forfeitures occur, the amount of dividends and dividend equivalents previously charged to retained earnings related to awards that are forfeited. ASC paragraph 718-10-55-45

4.123 Some share option awards provide for reductions in the exercise price based on the amount of dividends paid on the underlying shares during the vesting period. Other share option awards receive nonforfeitable dividends as they are earned. In each of these circumstances, the grant-date fair value of the award would be calculated using a dividend yield of zero. (Refer to Section 2 for a discussion of the treatment of dividends in measuring the grant-date fair value of the award.) ASC paragraph 718-10-55-44

LIABILITY-CLASSIFIED AWARDS

4.124 Both liability-classified awards and equity-classified awards are initially measured at their grant-date fair value (see Section 3, *Classification of Awards as Either Liabilities*

or Equity). However, at each financial reporting date until settlement of the award, the fair value of a liability-classified award is remeasured based on the current share price and other pertinent factors at the reporting date. During the employee's requisite service period or nonemployee's vesting period, compensation cost recognized for a liability-classified award is based on the proportionate amount of the employee requisite service that has been rendered to date, or for nonemployee awards, the percentage that would have been recognized had the grantor paid cash for the goods or services. For awards with graded vesting that are liability-classified, an entity should apply the same policy elections that are used for other awards (whether equity- or liability-classified). See Paragraphs 4.080-4.080b. Changes in fair value of the liability-classified award after the employee's requisite service period or nonemployee's vesting period has been completed are immediately recognized as compensation cost in the period in which the change in fair value occurs. As a result, compensation cost related to a liability-classified award will continue to have variability based on changes in the award's fair value from the grant date (or service inception date if earlier) until the settlement date, unless for some reason the award becomes equity classified before that date. ASC paragraph 718-30-35-2

4.125 ASC Topic 718 is not explicit in the accounting for dividends or dividend equivalents that are paid on share-based payment awards that are liability-classified. The guidance in ASC Topic 480, *Distinguishing Liabilities from Equity*, which states that dividends paid on instruments that are classified as a liability should be reflected as interest cost, is analogous to the accounting for dividends or dividend equivalents paid on share-based payment awards that are liability-classified, and therefore those dividends or dividend equivalents should be recorded as compensation cost. The payment of dividends on share-based payment awards that are liability-classified will have an offsetting effect on the fair value of the liability at the next measurement date. The tax effects of the additional compensation should be recorded under the guidance in ASC Topic 718, as that issue only applies to equity-classified awards.

4.126 At the time of settlement, the fair value of a liability-classified award recognized in the entity's financial statements might exceed its intrinsic value. This difference is related to the remaining time value of the award and would be recognized as a reduction in compensation cost in the period the award is settled. As a result, the cumulative compensation cost recognized for a liability-classified award is equal to its intrinsic value at the time of settlement. ASC paragraph 718-30-35-2

Example 4.41: Liability-Classified Award with No Forfeitures

On January 1, 20X3, ABC Corp. grants 100,000 cash-settled share appreciation rights (SARs) to management that entitle the holders to receive cash equal to the increase in the market value of one share of ABC's stock above the \$15 market price on the grant date. The award vests at the end of four years and has a contractual term of 10 years. Assume that there are no forfeitures of the awards.

Background

| | |
|-----------------------|---|
| SARs granted | 100,000 |
| Vesting schedule | 100% at end of four years (cliff vesting) |
| Grant-date fair value | \$10 per SAR |

Fair value for the SARs is calculated at grant-date and each subsequent reporting date during both the requisite service period and each subsequent period until settlement. Assume the share prices and fair values below and that all of the SARs are cash-settled on December 31, 20X8. Compensation cost is determined as follows:

| At December 31 | Share Price | Fair Value | Total Compensation Cost |
|----------------|-------------|--------------------|-------------------------|
| 20X3 | \$ 20.00 | 8.00 | 800,000 |
| 20X4 | 25.00 | 15.00 | 1,500,000 |
| 20X5 | 17.00 | 4.00 | 400,000 |
| 20X6 | 22.00 | 11.00 | 1,100,000 |
| 20X7 | 25.00 | 14.00 | 1,400,000 |
| 20X8 | 27.50 | 12.50 ¹ | 1,250,000 |

¹ Fair value equals intrinsic value at settlement (intrinsic value of SARs of \$12.50 = \$27.50 - \$15.00).

| | 20X3 | 20X4 | 20X5 | 20X6 | 20X7 | 20X8 |
|---|------------------|----------------|------------------|----------------|----------------|------------------|
| Total compensation cost | \$800,000 | 1,500,000 | 400,000 | 1,100,000 | 1,400,000 | 1,250,000 |
| Proportion of requisite service period provided to date | 25% | 50% | 75% | 100% | 100% | 100% |
| Cumulative compensation cost | 200,000 | 750,000 | 300,000 | 1,100,000 | 1,400,000 | 1,250,000 |
| Cumulative compensation cost previously recognized | 0 | 200,000 | 750,000 | 300,000 | 1,100,000 | 1,400,000 |
| Current year expense (income) | <u>\$200,000</u> | <u>550,000</u> | <u>(450,000)</u> | <u>800,000</u> | <u>300,000</u> | <u>(150,000)</u> |

Subsequent to the completion of the requisite service period, any changes in the fair value of the SARs through ultimate settlement of the award are recognized immediately as compensation cost in the period of change.

Example 4.42: Liability-Classified Award with Forfeitures

On January 1, 20X3, ABC Corp. grants 100,000 cash-settled SARs to management that entitle the holders to receive cash equal to the increase in the market value of one share of ABC's stock above the \$15 market price on the grant date. The award vests at the end of four years and has a contractual term of 10 years.

Background

| | |
|-----------------------------------|--|
| SARs granted | 100,000 |
| Vesting schedule | 100% at end of Year 4 (cliff vesting) |
| Grant-date fair value | \$10 per SAR |
| Initial estimate of forfeitures | 10,000 SARs |
| Change in estimate of forfeitures | At the beginning of Year 3, SARs expected to be forfeited are 15,000 |

Fair value for the SARs is calculated at grant-date and each subsequent reporting date during both the requisite service period and each subsequent period until settlement. Assume the share prices and fair values below and that all of the SARs are cash-settled on December 31, 20X8. Compensation cost is determined as follows:

| At December 31 | Share Price | Fair Value | SARs Expected to Vest | Actual forfeitures | Total Compensation Cost |
|----------------------|-------------|--------------------|-----------------------------|-----------------------|----------------------------|
| 20X3 | \$20.00 | \$8.00 | 90,000 | 5,000 | \$720,000 |
| 20X4 | 25.00 | 15.00 | 90,000 | 5,000 | 1,350,000 |
| 20X5 | 17.00 | 4.00 | 85,000 | 5,000 | 340,000 |
| 20X6 | 22.00 | 11.00 | 85,000 | — | 935,000 |
| 20X7 | 25.00 | 14.00 | 85,000 | — | 1,190,000 |
| 20X8 | 27.50 | 12.50 ¹ | 85,000 | — | 1,062,500 |

¹ Fair value equals intrinsic value at settlement (intrinsic value of SARs of \$12.50 = \$27.50 - \$15.00).

After 20X6, the requisite service period has been completed and no further forfeitures can occur. In this example, it is assumed that all remaining 85,000 SARs will settle at the end of 20X8.

Scenario 1 – ABC's policy is to estimate forfeitures in determining the amount of compensation cost to recognize each period.

4. Recognition of Compensation Costs

| | 20X3 | 20X4 | 20X5 | 20X6 | 20X7 | 20X8 |
|---|-----------|-----------|-----------|---------|-----------|-----------|
| Total compensation cost | \$720,000 | 1,350,000 | 340,000 | 935,000 | 1,190,000 | 1,062,500 |
| Proportion of requisite service period provided to date | 25% | 50% | 75% | 100% | 100% | 100% |
| Cumulative compensation cost | 180,000 | 675,000 | 255,000 | 935,000 | 1,190,000 | 1,062,500 |
| Cumulative compensation cost previously recognized | 0 | 180,000 | 675,000 | 255,000 | 935,000 | 1,190,000 |
| Current year expense (income) | \$180,000 | 495,000 | (420,000) | 680,000 | 255,000 | (127,500) |

Scenario 2 – ABC’s policy is to recognize forfeitures as they occur (20X7 and 20X8 are the same as in Scenario 1).

| | 20X3 | 20X4 | 20X5 | 20X6 |
|---|------------------------|--------------------------|------------------------|-----------|
| Total compensation cost | \$760,000 ¹ | \$1,350,000 ² | \$340,000 ³ | \$935,000 |
| Proportion of requisite service period provided to date | 25% | 50% | 75% | 100% |
| Cumulative compensation cost | \$190,000 | \$675,000 | \$255,000 | \$935,000 |
| Cumulative compensation cost previously recognized | \$0 | \$190,000 | \$675,000 | \$255,000 |
| Current year expense (income) | \$190,000 | \$485,000 | (\$420,000) | \$68,000 |

1 100,000 SARs – 5,000 actual forfeitures = 95,000 SARs x \$8 fair value

2 100,000 SARs – 10,000 cumulative forfeitures = 90,000 SARs x \$15

3 Cumulative forfeitures of 15,000; 85,000 SARs x \$4

After the completion of the requisite service period, no further forfeitures are possible and any changes in the fair value of the SARs through ultimate settlement of the award are recognized immediately as compensation cost in the period of change.

4.127 A share-based payment award accounted for in the same manner as an employee cash bonus award (i.e., in accordance with ASC Topics 450 and 710) should not reflect a discount for the present value of the amounts expected to be paid on vesting at a future date. If the payment to the employee coincides with the completion of the vesting period, then a discount for the present value of the award at the grant date would be inappropriate because delayed payments due to vesting restrictions are not considered in determining the grant-date fair value. To the extent that the payment to the employee was nonforfeitable on vesting, but was not to be paid until a date beyond the completion of the vesting period, then the delayed payment would be considered a post-vesting restriction and would be incorporated in the determination of the grant-date fair value.

Q&A 4.24: Bonus Plan

Background

On January 1, 20X6, ABC Corp. establishes a bonus plan for its executives with the following terms:

- Eligibility based on meeting a specified sales target for 20X6;
- Payout is based on a fixed dollar amount to be settled in shares of ABC (e.g., if sales target is met, the executives will receive shares worth \$100,000 in value);
- Number of shares to be issued based on ABC's stock price at December 31, 20X6; and
- The shares will be issued on January 1, 20X7.

Q. How should an award be classified? When will the compensation cost be recognized?

A. The award is treated as a cash bonus award to be settled in shares of ABC stock (i.e., a share-settled liability). The award establishes a liability to be estimated during the performance period. It is accounted for in the same manner as a cash bonus award (i.e., accrued over the one-year service period in accordance with ASC Topic 450 and ASC paragraphs 710-10-25-9 through 25-11).

Q&A 4.25: Bonus Plan with a Subsequent Service Period

Background

Assume the same facts as in Q&A 4.24, except that the award will be settled in nonvested shares for which the executives are required to provide one additional year of service for the shares to vest (i.e., vesting will occur on December 31, 20X7).

Q. How should the award be classified? When will the compensation cost be recognized?

A. The award is treated as a cash bonus award to be settled in nonvested shares of ABC. Assuming that the performance condition is substantive, the requisite service period for the award is two years. The award is classified as a liability until the number of shares is fixed. At that time, the award becomes equity-classified.

Example 4.43: Bonus Plan with a Look-Back Feature

ABC Corp. has an annual cash bonus plan that establishes performance targets on January 1 of each year. Each individual has a target bonus amount and the amount of the target that is earned is subject to the following percentage multiplier:

| EPS | % of Target |
|------------------------------|-------------|
| Less than or equal to \$0.90 | 0% |
| \$.091 to \$1.00 | 75% |
| \$1.01 to \$1.10 | 100% |
| Greater than \$1.10 | 125% |

In addition, employees may elect to allocate a percentage of their bonus toward the purchase of ABC's common stock. This election is made by the employees on January 1 and is irrevocable. The purchase price of the common stock is equal to the lower of (1) 80% of the market price on January 1 or (2) 80% of the market price on December 31 of that same year.

Assumptions

- CEO has a targeted bonus amount of \$200,000 for fiscal year 20X7;
- On January 1, 20X7, CEO elects to allocate 40% of the bonus toward the purchase of common stock;
- Market price of ABC's stock on January 1, 20X7 is \$10;
- Market price of ABC's stock on December 31, 20X7 is \$8; and
- EPS for the year ended 20X7 is \$1.11.

Based on the CEO's election, the bonus plan comprises two awards that are accounted for separately. The first award is the annual cash bonus plan, which comprises 60% of the award for the CEO. In this situation, the CEO's annual cash bonus could be one of four possible amounts based on the final EPS results: \$0; \$90,000 ($75\% \times \$200,000 \times 60\%$); \$120,000 ($100\% \times \$200,000 \times 60\%$); and \$150,000 ($125\% \times \$200,000 \times 60\%$). ABC should recognize a cash bonus expense in a systematic and rational manner over the one-year bonus plan period based on the estimated most likely outcome of these four possibilities in accordance with ASC paragraphs 710-10-25-9 through 25-11. This estimate should be reviewed each reporting period with any changes in the most likely outcome being recognized on a cumulative basis.

The second award is an employee share purchase plan (ESPP) award with a look-back option for the 40% of the award to be used to buy common stock. This ESPP is compensatory under ASC paragraph 718-50-25-1. Contribution percentages made to the ESPP are determined by January 1, are irrevocable, and cannot be increased or decreased. Therefore, the grant date is January 1. This plan is akin to a Type B plan as described in ASC Section 718-50-55 (see discussion beginning at Paragraph 11.004). Therefore, the grant-date fair value of this ESPP award should be determined on January 1 based on the accounting for Type B Plans. Based on the example described above, the grant-date fair value of this award, based on the three components of value under a Type B plan, would be calculated at January 1 as: (See discussion beginning at Paragraph 2.162)

| | | |
|-----|--|---------------------|
| (1) | The discount per share (\$10 × 20% discount) | \$2.00 |
| (2) | One-year call option on 0.80 of a share of stock | \$1.68 ¹ |
| (3) | One-year put option on 0.20 of a share of stock | \$0.30 ² |
| | Grant-date fair value of an award | \$3.98 |

¹ Black-Scholes Value for call option × 0.80

² Black-Scholes Value for put option × 0.20

The total grant-date fair value is dependent on the number of awards that ultimately vest (which is based on the bonus target actually earned). Per ASC paragraph 718-50-55-25, ABC would *not* consider the potentially greater number of shares that may ultimately be purchased if the market price declines, because it has already been considered in the valuation of the put. Similar to the cash bonus, there are four possible outcomes for the total grant-date fair value to be recognized as compensation cost.

| A | B=A × 40% | C=B/(\$10 stock price × 80%) | D=C × \$3.98 |
|------------------|-----------------------------------|--|---|
| Bonus Earned | Portion of bonus elected for ESPP | Number of shares that can be purchased based on January 1 stock price and 20% discount | Number of shares time grant-date fair value |
| 0% = \$0 | \$0 | 0 | \$0 |
| 75% = \$150,000 | \$60,000 | 7,500 | \$29,850 |
| 100% = \$200,000 | \$80,000 | 10,000 | \$39,800 |
| 125% = \$250,000 | \$100,000 | 12,500 | \$49,750 |

In addition to the bonus earned in the first award, which is recognized separately, ABC should recognize compensation cost related to the second award at the grant-date fair value ratably over the one-year requisite service period based on the most likely outcome of these four possibilities. This estimate should be reviewed each reporting period and changes in the most likely outcome should be recognized on a cumulative basis.

Because the target achieved is the same for the cash bonus and the ESPP, ABC should have the same determination of the most likely outcome for both awards. For example, if the bonus earned in the first award is at the \$80,000 level, this amount is recognized for the annual cash bonus plan, and \$39,800 is recognized for the ESPP.

CLASSIFICATION OF COMPENSATION COST

4.128 ASC Topic 718 does not address the financial statement classification of compensation cost recognized from a share-based payment arrangement. Like any other recognized cost, the entity determines the functional nature of the cost and classifies it accordingly. Investors that are SEC registrants should classify any income or expense resulting from recognizing stock-based compensation granted to employees of an equity method investee in the same income statement caption as the equity in earnings (or losses) of the investee.

4.129 The compensation cost to grantees should be treated in the same manner as other components of compensation cost. As a result, the compensation cost might be included in an expense category, such as research and development or selling and administrative. Some companies parenthetically indicate the amount of share-based compensation cost included in each line item. It is unacceptable to include all share-based payment compensation cost on a separate line item in the income statement.

4.130 Alternatively, the cost might be capitalized as part of the cost of an asset to the extent that the share-based payment awards are granted to grantees whose compensation cost is capitalized as part of the acquisition cost of an asset. Examples of classes of assets as part of which compensation cost might be capitalized include:

- Inventory;
- Self-constructed property, plant, and equipment;
- Loan origination fees and costs capitalized in accordance with ASC Subtopic 310-20, *Receivables – Nonrefundable Fees and Other Costs*;
- Deferred acquisition costs in the insurance industry;
- Computer software costs capitalized in accordance with ASC Subtopic 985-20, *Software – Costs of Software to Be Sold, Leased, or Marketed*, or ASC Subtopic 350-40, *Intangibles--Goodwill and Other – Internal-Use Software*;
- Contract costs for arrangements accounted for in accordance with ASC Subtopic 605-35, *Revenue Recognition – Construction-Type and Production-Type Contracts*¹;
- Direct-response advertising costs capitalized in the limited situations described in ASC Subtopic 720-35, *Other Expenses – Advertising Costs*;
- Mine development costs;
- Exploration costs capitalized in the oil and gas industry; and

- Goodwill or other acquired assets as a consequence of share options issued to effect a business combination.

In addition, upon adoption of the new revenue accounting standard (ASC 606), certain incremental costs of obtaining a contract and costs to fulfill a contract in accordance with ASC Subtopic 340-40, *Other Assets and Deferred Costs – Contracts with Customers*

¹ ASU 2014-09, Revenue from Contracts with Customers (Topic 606), supersedes the revenue recognition requirement in Topic 605, *Revenue Recognition*, including some cost guidance included in Subtopic 605-35.

4.131 When compensation cost is properly capitalized as part of the cost of an asset, the related expense will not be recognized in the same period as the compensation cost. In this situation, entities should have a process in place to determine the appropriate classification and subsequent accounting for the related compensation cost.

Q&A 4.25.1: Capitalization of Compensation Cost

Background

ABC is a steel manufacturing company. During 20X9, ABC decided to reward its manufacturing department employees by granting them share options. ABC determined that the cost of the manufacturing department employees' service is an inventoriable cost.

Q. How should ABC recognize the share options to its manufacturing department employees, and also account for its period-end inventory balance for the amount of share-option cost?

A. ABC capitalizes the cost of the share option grants as inventory during the requisite service period and subsequently recognizes the cost that is capitalized in inventory in the income statement when the inventory is sold. Topic 718 provides no specific method to use to incorporate a portion of the share-option costs in an inventory-costing system. SAB Topic 14.I states that a company may accomplish accounting for its period-end inventory balance by incorporating the share-option cost through either its inventory costing system or by recognizing a period-end adjustment to its financial statements.

4.132 – 4.135 Not used.

EMPLOYER LOAN FEATURES

4.136 Employers may provide financing to employees for the purchase of stock or the payment of the exercise price of share options. For public companies, there are regulatory limits on such loans under the Sarbanes-Oxley Act of 2002. The financing may be recourse or nonrecourse notes and the accounting for these loans depends on certain factors in addition to the form of the note. A nonrecourse loan represents an employee loan that is collateralized only by the stock purchased and the employer's only recourse is

to the stock itself. A recourse loan represents a loan that the company is able, and clearly intends, to foreclose on the employee's other assets in the event of default by the employee.

Nonrecourse Loan to Employees

4.137 ASC paragraph 718-10-25-3 indicates that stock compensation arrangements should be accounted for according to their substance. For example, the rights and obligations embodied in a transfer of equity shares to an employee for a note that provides no recourse to other assets of the employee (i.e., other than the shares) are substantially the same as those embodied in a grant of share options. Thus, the transaction would be accounted for as a share option grant regardless of the use of the proceeds of the note by the employee.

4.138 The terms of a share-based payment award and related arrangements need to be reflected in the measurement of the fair value of the award. For example, the fair value of a substantive share option structured as the exchange of equity shares for a nonrecourse note will differ depending on whether the employee is required to pay nonrefundable interest on the note (i.e., the nonrecourse principal and interest is considered part of the exercise price of the share option). If an employee is required to pay nonrefundable interest on the nonrecourse note, the employer should not recognize interest income on the note as the interest is a component of the exercise price of the option. In addition, determining fair value for the share option should include the increasing share option exercise price. Nonrefundable payments (e.g., periodic principal and interest payments) are treated as deposits and are accounted for as a credit to APIC as received. Refundable payments are also treated as deposits, but instead are recorded as a liability until the nonrecourse note is paid off, at which time the deposit balance is transferred to APIC.

4.138a A company may issue nonrecourse notes to employees for the exercise of an equity-classified stock option award with the note having a variable interest rate linked to a third-party index (e.g., SoFR, Federal Interest Rates). As a result of the variable interest rate being linked to a third-party index, the exercise price of the award is linked to something other than a service, performance, or market condition (an "other" condition) and, therefore, the award is liability-classified. See Paragraph 3.006 for further guidance surrounding *other* conditions.

Q&A 4.26 – 4.28 Not used.

Q&A 4.29: Consideration of Interest on a Nonrecourse Note in the Measurement of Grant-Date Fair Value of a Share-Based Payment Award

Q. How should interest on a nonrecourse note be considered in the measurement of the grant-date fair value of a share-based payment award?

A. If the nonrecourse note specifies that interest will accrue on the note balance and the interest also is nonrecourse, then the substance of the arrangement is a share option with an increasing exercise price. This type of award could be valued using a Black-Scholes-Merton model with the original principal amount, the expected term of the option, and the stated interest rate used to compute a strike price that would be used as inputs to the model. For example, if the current price per share inherent in the original note balance is \$100, the interest rate on the note is 5% compounded annually, and the expected term of the share option is 2 years, the strike price used as an input to determine the grant-date fair value of the award is $100 \times (1+0.05)^2$ or 110.25. Another approach is to value the share options by deducting from the discount rate the annual percentage increase in the exercise price. For example, if the risk free rate is 8% and the interest on the note is 5%, the input of the risk free rate to the Black-Scholes model would be 3% (8%-5%), and the strike price would be the principal balance of the note without the adjustment.

If the interest on the note is paid periodically and the interest is nonrefundable, a more complex model (i.e., Binomial model or Monte Carlo simulation model) may be needed to determine the fair value. Alternatively, an approximation method may be used, such as valuing the arrangement as a plain vanilla option without the interest component calculated using the Black-Scholes-Merton model and then deducting from the result the present value of the periodic interest payments discounted at a risk adjusted discount rate. The interest payments are discounted at a risk-adjusted rate to reflect the credit risk inherent in the future stream on interest payment. However, this method may be complicated by consideration of the in/out-of-the-money probability. If the share option is out-of-the-money, and the interest paid by the employee is nonrefundable, the employee is expected to return the shares and cancel the note, because the note is nonrecourse. This may occur at any point in the term of the arrangement when the value of the share option is lower than the current interest payment due plus the present value of all future interest payments. If this occurs, it would not be viewed as a forfeiture if the employee's service continues, and compensation cost would still be recognized if the requisite service is rendered in accordance with the guidance in ASC Topic 718.

Because the interest is deemed to be a component of the exercise price of the share option, the employer would not recognize interest income.

4.138b A company may issue nonrecourse notes to employees, but in certain circumstances the nonrecourse note is only for the amount to cover the tax withholdings. Even when the nonrecourse note is only for the amount to cover the tax withholdings, because there is no recourse to other assets of the employee (i.e., other than the shares), the nonrecourse note arrangement to cover the withholding taxes has substantially the same characteristics as those embodied in a grant of share options (the employee could just return the underlying shares instead of paying off the nonrecourse note). Thus, the nonrecourse note transaction would be accounted for as a share option grant.

4.138c The maturity date of a nonrecourse note provides the maximum term of the option in estimating the expected term input for determining the option's grant date fair value. The maturity date does not affect the requisite service period for such awards granted to

employees, or the vesting period for such awards granted to nonemployees. For example, if a nonrecourse note issued in exchange for shares granted to employees matures in 10 years but is prepayable at any time and there is no requirement for the grantee to provide ongoing services, the 10-year maturity period would be irrelevant in the determination of the requisite service period. Instead, the 10-year maturity period would be considered the maximum term of the option, and compensation expense would be recognized immediately since there is no ongoing service requirement. Conversely, if the nonrecourse note was not prepayable and the grantee is required to provide ongoing services at maturity of the nonrecourse note to retain the awards, the 10-year period would be both the vesting period and the expected term of the option.

Q&A 4.29a: Subsequent Issuance of Nonrecourse Loan for Cash

Q. How should an entity account for a loan to an employee that provides no recourse other than the current equity interests of the employee (e.g., previously vested restricted stock units)?

A. An entity may grant a nonrecourse loan to the employee to provide the employee with cash collateralized only by shares the employee already owns. Even if a nonrecourse employee loan is not issued contemporaneously with a share-based compensation arrangement or used to pay the exercise price of a share option, the subsequent issuance of the loan changes the economic substance of the existing equity awards into a share option similar to that described in ASC paragraph 4.137. The issuance of the nonrecourse loan in substance represents a repurchase of the existing awards and concurrent grant of new awards in the form of share options. ASC paragraph 718-10-25-3

The fair value of the new share options and cash should be compared to the fair value of the original equity award to determine if the repurchase amount is in excess of the fair value of the original awards, representing incremental compensation cost. See Section 5, beginning at Paragraph 5.026. ASC paragraph 718-20-35-7

Recourse Loan to Employees

4.139 If an entity has recourse to the general assets of the employees, those assets are sufficient to cover the value of the loan, and the entity intends to pursue its recourse in the event of default, the guidance of ASC paragraph 718-10-25-3 would not apply. However, notes may be legally structured as recourse notes, but all facts and circumstances should be considered including the following factors originally provided in Issue 34 of EITF 00-23, which was nullified by ASC Topic 718:

- (a) The employer has legal recourse to the employee's other assets but does not intend to seek repayment beyond the shares issued,
- (b) The employer has a history of not demanding repayment of loan amounts in excess of their fair value of the shares,

- (c) The employee does not have sufficient assets or other means beyond the shares to justify the recourse nature of the loan, or
- (d) The employer has accepted a recourse note on exercise and subsequently converted the recourse note to a nonrecourse note.

4.140 If (a), (b), (c), or (d) is present in the fact pattern, the recourse note should be considered to be in substance nonrecourse in nature. Therefore, the arrangement continues to be a share option award for accounting purposes. In addition to criteria (a), (b), (c), or (d), all other relevant facts and circumstances should be evaluated when determining whether the note is considered to be in substance recourse in nature. If an entity extends the payment terms of a recourse note, the entity should evaluate the reason for the extension and whether factors (a), (b), (c), or (d) are also present. If one of the factors is present at the time of the recourse note extension, the recourse note is generally treated in substance as a nonrecourse note for accounting purposes. Additionally, the entity should treat the note as in substance nonrecourse if it is probable that the employee will not have sufficient assets or other means beyond the shares to support the recourse nature of the note.

4.141 If the concepts in Issue 34 of EITF 00-23 do not apply and the entity has recourse to the employee's assets and intends to exercise those rights in the event of default, the note receivable should be recorded as reduction of shareholders' equity under ASC paragraphs 310-10-45-14, 505-10-45-1, and 45-2. If an entity forgives a recourse note, on the date of forgiveness the entity records compensation cost. The compensation cost includes the amount of the note and any accrued interest forgiven. In addition, compensation cost should be reduced by any recoveries received.

4.141a If an entity converts a recourse note to a nonrecourse note, the conversion is accounted for as the repurchase (a treasury stock purchase) of the shares issued to the employee and the grant of a new award in exchange for a nonrecourse note. The entity recognizes compensation cost over the requisite service period (if any) of the new award for any amount by which the repurchase amount exceeds the fair value of the shares repurchased. Any changes made to a nonrecourse or recourse note should be assessed under the guidance in ASC paragraph 718-20-35-2A as to whether modification accounting is required.

4.141b If an entity subsequently agrees to finance the exercise price for previously granted share options by providing either recourse or nonrecourse notes, the issuance of such promissory notes should be assessed under the guidance in ASC paragraph 718-20-35-2A to determine whether modification accounting is required.

4.142 If an entity permits an employee to exercise a share option with a noninterest-bearing or below-market interest rate, the exercise or purchase price of the share-based payment award is equal to the fair value of the note (i.e., the present value of the principle and interest using a discount rate equivalent to a market rate). Accordingly, the granting of a noninterest or below-market interest rate loan results in a reduction of the exercise price of the award. This will result in an increase in the grant-date fair value of the award and an increase in the amount of compensation cost to be recognized by the entity. For

example, assume an entity grants a \$10,000 noninterest-bearing full recourse loan payable in three years to an employee for the exercise of share options. The fair value of the stock on the date of purchase is \$10,000, and the market rate of interest on the loan is 8%. This would result in the stock's fair value of \$7,938 (the present value of \$10,000 in three years, discounted 8%). Therefore the difference of \$2,062 (\$10,000 less \$7,938) is recognized as additional compensation cost by the entity over the three-year period.

Combination Recourse and Nonrecourse Loan to Employees

4.143 Issue 34 of EITF 00-23 also addressed the exercise of awards with a nonrecourse note for a portion of the total exercise price and a recourse note for the remainder of the exercise price. If the exercise price or purchase price for each share is represented on a pro rata basis by both nonrecourse and recourse notes (e.g., 25% of the exercise price is nonrecourse and 75% is recourse), including the nonrecourse note causes both notes to be treated as nonrecourse, regardless of the relative percentages of the recourse and nonrecourse notes to the total exercise price. However, if a pro rata portion of the underlying shares, as opposed to a pro rata portion of the exercise price per share, is represented by nonrecourse and recourse notes, respectively, the entity would account for each portion of shares on a nonrecourse and recourse basis, respectively.

AWARDS GRANTED TO CUSTOMERS

4.144 Awards granted to customers are considered consideration payable to a customer and recognized as a reduction of revenue under ASC Topic 606 unless they represent a fair-value payment for a distinct good or service (in which case they are recognized as a nonemployee award to acquire that good or service under ASC Topic 718). However, the measurement and classification of the award is determined based on ASC Topic 718. Therefore, when the equity-based instruments are accounted for as consideration payable to a customer, the grant date fair value is recognized as a reduction of revenue in the same manner as if the entity made a cash payment to the customer. Refer to KPMG Handbook, Revenue recognition, Chapter 5, Question 5.7.20 for further discussion of timing of recognition, including consideration of vesting conditions for equity awards granted to customers.

¹ Big R or little r restatements – see KPMG Handbook, Accounting changes and error corrections, Chapter 4

Section 5 - Modification of Awards

Detailed Contents

General Model for a Modification of an Equity-Classified Award

Example 5.1: Modification of Vested Share Options

Example 5.2: Modification of Unvested Share Options

Example 5.2a: Modification of Unvested Share Options Graded Vesting

Q&A 5.1: Modification to Increase Period for Which Share Options Are Exercisable

Q&A 5.2: Modification to Permit Net-Share Settlement

Q&A 5.3: Modification to Increase Exercise Period after Retirement

Q&A 5.3a: Modification to Increase Exercise Period after Termination

Q&A 5.3b Modifications That Occur Frequently

Modifications That Affect Vesting Conditions

Example 5.3: Modification to Accelerate Unvested Share Options on Termination

Q&A 5.4: Acceleration of Vesting on Termination

Q&A 5.5: Acceleration of Vesting on Involuntary Termination

Q&A 5.6: Modification That Affects Vesting and Grant Date – Part I

Q&A 5.6a: Modification That Adds Early Exercise Feature to Share Options - Part II

Q&A 5.7: Acceleration of Vesting of Out-of-the-Money Share Options

Q&A 5.7a: Modification When an Entity's Accounting Policy Is to Account for Forfeitures as They Occur

Example 5.4: Acceleration of Vesting of a Service Condition – Alternative I

Example 5.4a: Acceleration of Vesting of a Service Condition – Alternative II

Example 5.5: Type III Modification With Initial Estimated Forfeiture Rate of 0% or When A Company Accounts for Forfeitures When They Occur

Modifications That Affect Vesting Conditions and Fair Value

Example 5.6: Modification of Fully Vested Share Options That Affects Vesting and Fair Value

Example 5.7: Modification of Unvested Share Options That Affects Vesting and Fair Value

Modifications that Affect Transferability

Modifications That Affect Performance Conditions

Example 5.8: Modification of Performance Conditions

Example 5.9: Modification of Performance Condition – Not Probable to Probable

Example 5.9a: Modification of Performance Condition – Not Probable to Probable

Example 5.10: Modification of Performance Condition – Probable to Probable

Example 5.10a: Modification of Performance Condition – Not Probable to Not Probable

Example 5.11: Modification of Performance Target – Not Probable to Probable for Tranche

Excerpt from ASC 718-20-55-109; 55-113 through 55-115

Excerpt from ASC 718-20-55-109; 55-116; 55-117

Modification of a Performance Target in Response to a New Accounting Standard or other specified event

Modifications That Affect Awards with Market Conditions

Example 5.12: Modification of a Market Condition in an Award

Modifications Regarding an Award's Classification

Example 5.13: Modification of an Award That Changes Its Classification from Equity to Liability - Part I

Example 5.14: Modification of an Award That Changes Its Classification from Equity to Liability - Part II

Example 5.15: Modification of an Award That Changes Its Classification from Liability to Equity – Part I

Example 5.16: Modification of an Award That Changes Its Classification from Liability to Equity – Part II

Application of ASC Paragraph 480-10-S99-3 When a Modification of an Award with a Contingent Cash Redemption Feature Occurs

Example 5.17: Modification of an Award Containing a Contingent Redemption Feature

Settlement of Awards

Example 5.18: Settlement of Vested Share Options

Example 5.19: Settlement of Unvested Shares – Alternative I

Example 5.20: Settlement of Unvested Shares – Alternative II

Q&A 5.7b: Separation Agreement Resulting in Modification Accounting for Awards

Q&A 5.7bb: Excise Tax on Repurchases if the Price Is in Excess of Fair Value

Short-Term Inducements

Example 5.20b: Short-Term Inducement

Q&A 5.7c: Grantee Sales of Immature Shares in a Secondary Offering

Cancellations

Example 5.21: Cancellation of an Award and the Concurrent Grant of a Replacement

Example 5.21a: Cancellation of an Unvested Award

Q&A 5.8: Demotion of an Employee

Q&A 5.9: Cancellation and Issuance of Awards in Connection With the Emergence from Chapter 11

Example 5.21b: Modification of Awards Previously Accounted for under ASC Topic 710

Modification to Accelerate Vesting

Awards Modified to Accelerate Vesting before Event Is Contemplated

Example 5.22: Addition of an Acceleration Provision for Change of Control Not in Contemplation of a Change of Control Event

Awards Modified to Accelerate Vesting In Contemplation of an Event

Example 5.23: Adding an Acceleration Provision Made in Contemplation of an Employee Termination Without Cause

Example 5.24: Adding an Acceleration Provision Made in Contemplation of a Change in Control

Q&A 5.10: Modification Made in Contemplation of an Event

Equity Restructurings

Awards That Contain Anti-Dilution Provisions as Part of Existing Terms

Example 5.25: Equity Restructuring with Awards That Contain Anti-Dilution Provisions

Example 5.26: Modification of Awards That Contain Anti-Dilution Provision with a Partial Cash Settlement in Connection with Equity Restructuring

Awards Modified to Add an Anti-Dilution Provision Not Made in Contemplation of an Equity Restructuring

Awards Modified to Add an Anti-Dilution Provision Made in Contemplation of an Equity Restructuring

Example 5.27: Adding an Anti-Dilution Provision in Contemplation of an Equity Restructuring Resulting in One Modification

Example 5.28: Adding an Anti-Dilution Provision in Contemplation of an Equity Restructuring That Results in Two Modifications

Example 5.29: Adding an Anti-Dilution Provision with a Partial Cash Settlement in Connection with Equity Restructuring

Discretionary Modifications Related to Equity Restructurings

Example 5.30: Accounting Treatment if Management's Percentage Ownership Interest Remains Consistent Before and After an Equity Restructuring

Tax Considerations

Awards Modified in Connection with a Spin-off

Q&A 5.11: Attribution of Compensation Cost When Spinor Awards are Exchanged for Spinee Awards

5.000 A modification of a share-based payment award is a change in the terms or conditions of an award and may result from changes in the share-based payment award plan document or as part of another agreement such as an employment or individual award agreement that provides the terms of the share-based payment award. Also see Paragraph 3.002. When there is a modification of an award, an entity should not apply modification accounting if all of the following are the same immediately before and after the modification:

- Fair value (or calculated value or intrinsic value, for entities that use either of those methods);
- Vesting conditions of the award; and
- The classification as either a liability or equity instrument.

5.000a ASC paragraph 718-20-35-2A states that if there is a change in fair value, vesting conditions, or the classification of an award, the modification of an equity-classified award is treated as the exchange or repurchase of the original award for a new award of equal or greater value. The accounting for the modification of an equity-classified award depends on the likelihood, at the date of the modification that the original award would have vested under its original terms. If, at the date of the modification, it is probable that the original award would have vested under its original terms, the cumulative compensation cost to be recognized equals the grant-date fair value of the original award plus the incremental value of the award given in the modification. However, if at the date of the modification it is *not* probable that the original award would have vested, the cumulative compensation cost to be recognized is the fair value of the modified award. The assessment of whether the original award would have vested under its original terms considers expected forfeitures. Therefore, regardless of an entity's accounting policy election for forfeitures, at the time of a modification, the entity assesses whether the original award was expected to vest under its original terms. The estimate of forfeitures related to the original award is required since that estimate can affect the cumulative compensation cost to be recognized as described above. In other words, even if an entity's accounting policy is to record forfeitures as they occur, an estimate of forfeitures is made at the time of a modification, to determine the type of modification (Type I through Type IV discussed in Paragraph 5.008) and whether a new measurement date has occurred for any awards. However, an entity's policy election for forfeitures will apply when it subsequently accounts for the modified award. ASC paragraphs 718-20-35-2A, 35-3, 35-3A and 35-4 and 718-30-35-5

5.000b When applying the guidance in ASC paragraph 718-20-35-2A to determine whether modification accounting needs to be applied, an entity may not need to estimate the value of an award immediately before and after the modification in all cases. When a modification does not change any of the inputs to the valuation technique for an award, then the entity is not required to quantitatively determine the value immediately before and after the modification. ASC paragraph 718-20-35-2A(a)

5.000c Examples of changes to an award that generally do not require modification accounting include:

- Administrative changes, e.g., company or plan name changes; and
- Changes in statutory tax withholdings that do not affect the classification of the award.

5.000d Examples of changes to an award that generally require modification accounting include:

- Repricing of share options that results in a change in value of those share options;
- Changes in a service, performance or market condition;
- Changes in an award that change the classification from equity to liability or vice versa; and
- An acceleration of vesting provision added to the plan in contemplation of an event, under which the awards are immediately vested if the related event occurs.

5.000e When determining the date on which a modification occurs, entities would consider the definition of a grant date provided in Topic 718. A grant date exists when there is a mutual understanding by both the grantor and the grantee of the key terms and conditions of the award. For a modification to occur, the grantee would need to understand the key terms and conditions of the modification. See Paragraph 4.028 for additional guidance about the conditions required to establish a grant date.

5.000f In applying the guidance in ASC paragraph 718-20-35-2A to determine whether modification accounting needs to be applied, judgment is needed to determine whether a fair value difference is an insignificant difference that would preclude modification accounting (e.g., a rounding difference). In addition, a company may need to use judgment to conclude that the fair value of an award is the same before and after a modification occurs when there is an insignificant fair value difference.

5.000g The guidance in ASC paragraph 718-20-35-2A as to whether modification accounting is required should be considered before applying the modification accounting guidance in Section 5.

5.001 Because grantees are unlikely to accept a modification that reduces the fair value of an award or reduces the likelihood that the award will vest, generally the terms or conditions of a modified award are at least as favorable as those under the original award. Therefore, a modification that makes an award less valuable or increases the likelihood of forfeiture should be carefully analyzed to determine if an additional form of consideration has been given or promised to persuade the grantee to accept the modification.

5.002 The modification of a liability-classified award also is treated as the exchange or repurchase of the original award for a new award of equal or greater value. Because liability-classified awards are remeasured at fair value (or intrinsic value for a nonpublic entity that elects, as an accounting policy, that method) through settlement, the guidance

discussed beginning at Paragraph 5.005 does not apply to liability-classified awards. This is because the consequences of the modification will be recognized when the award is remeasured at the next reporting date. ASC paragraph 718-20-35-3

5.003 Freestanding equity-classified written call options that are within the scope of Topic 815, but are modified or exchanged to compensate grantees in a share-based payment arrangement, are accounted for by applying the requirements in Topic 718; however, classification of the instrument will remain subject to the requirements of Subtopic 815-40. ASC paragraphs 718-10-15-5, 815-40-35-14

5.004 In addition to the accounting considerations described in this section, an employee award modification can result in significant tax consequences to both the company and the employees, *even for modifications with no accounting consequence*. Modifications of awards can trigger personal income taxes, excise taxes, and interest to employees on vesting of awards. Additionally, the modifications can result in disallowance of tax deductions on exercise of share options and vesting of nonvested shares to a company. For example, for tax purposes a modification may cause the employee award to be viewed as a newly granted award. If, for tax purposes, the employee award is viewed as a newly granted employee award and it is in the money on the modification date, the employee award may (1) be viewed as deferred compensation under Section 409A of the Internal Revenue Code (which may result in significant negative tax implications for the employee), (2) if granted to executives, be subject to limitation on the employer's tax deduction under Section 162(m) of the Internal Revenue Code, or (3) no longer qualify as an incentive stock option. Accordingly, companies should consider consulting with a tax professional when considering modifying the provisions to their awards to understand the potential tax consequences of the modification. See KPMG Handbook, Accounting for Income Taxes, Section 8, *Income Tax Issues Associated with Share-Based Payment Arrangements*, for further guidance.

GENERAL MODEL FOR A MODIFICATION OF AN EQUITY-CLASSIFIED AWARD

5.005 If there is a change in fair value, vesting conditions, or the classification of the award, a modification of the terms or conditions of an equity-classified award is treated as an exchange of the original award for a new award. In substance, the entity is deemed to have repurchased the original instrument by issuing a new instrument of equal or greater value thereby incurring additional compensation cost for any incremental value. In calculating the incremental compensation cost of a modification, the fair value of the modified award is compared to the fair value of the original award measured immediately before its terms or conditions are modified. For a share option, the current fair value of the original award is calculated using a valuation model that reflects the award's inputs (e.g., current share price) at the date of the modification.

An entity that has an accounting policy to account for forfeitures when they occur is required to assess at the date of the modification whether the performance or service

conditions of the original award are expected to be satisfied. See Paragraph 5.008 for further discussion. ASC paragraphs 718-20-35-2A, 35-3, 35-4 and 718-30-35-5

Example 5.1: Modification of Vested Share Options

On January 1, 20X6, ABC Corp. grants 20,000 share options with an exercise price of \$10 per share option (the current share price). The awards cliff vest after three years of service. The grant-date fair value is \$4 per share option. None of the awards were forfeited. Therefore, ABC recognized compensation cost of \$80,000 (20,000 share options × \$4) over the three-year employee requisite service period.

On March 31, 20X9, after the share options are vested, ABC decides to reduce the exercise price of the share options to \$3 (i.e., a repricing of the awards), which equals the current share price. No other terms or conditions of the original award are changed (the modified share options are fully vested). The fair value of the modified award is \$1.20 per share option. The fair value of the original award at the date of the modification is \$0.50 per share option (with an exercise price of \$10, the share options are deep out-of-the-money).

As the fair value of the award is not the same immediately before and after the change to the award, the entity accounts for the effect of the modification on March 31, 20X9. The incremental compensation cost for the modification is as follows (assumes that no share options have been exercised):

| | | |
|---|----|---------------|
| Fair value of modified share option at March 31, 20X9 | \$ | 1.20 |
| Less: Fair value of original share option at March 31, 20X9 | | <u>(0.50)</u> |
| Incremental compensation cost per share option | \$ | 0.70 |
| Number of awards modified | × | <u>20,000</u> |
| Additional compensation cost to be recognized | \$ | 14,000 |

The incremental compensation cost of \$14,000 is recognized immediately because the share options are fully vested as of the date of the modification. In calculating the fair value of the share option pre- and post-modification, the inputs used in the valuation model for both the original award and the modified award are the same except for the exercise price of the award (\$10 pre-modification and \$3 post-modification).

While this example describes employee awards, the modification would be accounted for similarly for nonemployee awards. However, compensation cost attribution for nonemployee awards may not necessarily be the same as for employee awards, because for nonemployee awards compensation cost is recognized in the same manner the grantor would if paying in cash. As these awards are modified when fully vested and stay fully vested after the modification, the additional compensation cost for nonemployee awards would be recognized immediately on modification, similar to the employee awards.

5.006 Incremental compensation cost related to the modification of an unvested award (i.e., the requisite service has not yet been completed) is recognized ratably over the remaining vesting term of the award. ASC paragraph 718-20-55-98

Example 5.2: Modification of Unvested Share Options

On January 1, 20X6, ABC Corp. grants 30,000 share options with an exercise price of \$20 per share option (the current share price). The awards cliff vest after three years of service. The grant-date fair value is \$6 per share option. ABC's policy is to account for forfeitures when they occur. During 20X6 no forfeitures are expected or occur, so ABC recognizes compensation cost of \$60,000 (30,000 share options \times \$6 \times 1/3).

On January 1, 20X7, ABC reduced the exercise price of the share options to \$10, which equals the share price at the date of the modification. No other terms or conditions of the award are changed. The fair value of the modified award is \$3.50 per share option and the fair value of the original award at the date of the modification is \$2.00 per share option.

As the fair value of the award is not the same immediately before and after the change to the award, the entity accounts for the effect of the modification on January 1, 20X7. The compensation cost recognized over the remaining employee requisite service period after the modification of the award (and assuming there are no forfeitures) is computed as follows:

| | |
|---|-------------------|
| Fair value of modified share option at January 1, 20X7 | \$ 3.50 |
| Less: Fair value of original share option at January 1, 20X7 | <u>(2.00)</u> |
| Incremental compensation cost per share option | \$ 1.50 |
| Number of awards modified | \times 30,000 |
| Additional compensation cost to be recognized | <u>\$ 45,000</u> |
| Unrecognized compensation cost on original award at the date of the modification (30,000 share options \times \$6 \times 2/3) | <u>\$ 120,000</u> |
| Total remaining compensation cost to be recognized | \$ 165,000 |

The remaining compensation cost of \$165,000 is recognized ratably over 20X7 and 20X8 (the remaining employee requisite service period).

While this example describes employee awards, the modification would be accounted for similarly for nonemployee awards. However, compensation cost attribution for nonemployee awards may not necessarily be the same as for employee awards, because for nonemployee awards compensation cost is recognized in the same manner the grantor would if paying in cash. As these awards are modified when the awards are unvested, the additional compensation cost for nonemployee awards would be recognized over an attribution period that would be used if the grantor paid cash instead of issuing share-based payment awards.

Example 5.2a: Modification of Unvested Share Options Graded Vesting

Assume the same facts as in Example 5.2, except that the options contain a graded vesting schedule (i.e., 1/3 of the options vest at the end of each year of service). In accordance with the accounting policy election to choose between straight-line or graded vesting attribution (see Paragraph 4.080), ABC Corp. records compensation cost on a straight-line basis over the total requisite service period for the entire award.

For the first year of service, ABC recognizes compensation cost of \$60,000 (30,000 share options \times \$6 \times 1/3). On the date of the modification, ABC determines the incremental compensation cost of \$45,000 (same as in Example 5.2). ABC records \$15,000 of incremental compensation cost immediately because 1/3 of the options have vested.

The remaining \$30,000 (\$45,000 less the \$15,000 recognized) of incremental compensation cost along with the \$120,000 of compensation cost associated with the modified awards (see calculation in Example 5.2) is recognized ratably over 20X7 and 20X8 (the remaining employee requisite service period).

Q&A 5.1: Modification to Increase Period for Which Share Options Are Exercisable

Background

ABC Corp. grants share options to grantees with terms that permit exercise after vesting only on the day that is at least three (3) and no more than twelve (12) business days after the public earnings release (the *window period*). This window period is shorter than required by insider trading restrictions under current securities laws. The contractual term of the share options is the shorter of 10 years from the grant date or 90 days from the date of termination.

The entity increased the window period for exercise of share options by an additional five business days, thereby increasing the periodic window to exercise the share options from 10 business days per quarter to 15 business days per quarter.

Q. Is the increase in a *self-imposed* window period for grantees to exercise existing share options a modification that results in an accounting consequence if the modification does not extend the contractual term beyond the original term of the award?

A. No. A modification to increase the exercise window without changing the contractual term or other conditions of the award does not result in an accounting consequence (i.e., new measurement date) as long as the modification does not extend the exercise period beyond the original term of the award. Although this modification increased the window period within which the share options can be exercised, the share options will still expire

10 years from the grant date, regardless of whether the expiration date occurs during the middle of an exercise window.

Q&A 5.2: Modification to Permit Net-Share Settlement

Q. Does the modification of an award to permit net-share settlement result in an accounting consequence?

A. No. For both vested and unvested share options, the modification to permit net-share settlement does not cause the share options to become more valuable nor does it affect the vesting conditions of the award, or cause the award to become liability-classified. Therefore, no incremental compensation cost is caused by the modification.

Q&A 5.3: Modification to Increase Exercise Period after Retirement

Q. A company grants share options to senior management with terms that require the vested option to be exercised within 90 days of retirement or involuntary termination of employment from the company. The company subsequently modifies the option plan to extend the exercise period to three years after retirement. The modification does not change the original contractual expiration term of 10 years for the options. Does this modification have an accounting consequence?

A. Yes. The modification would result in additional fair value of the awards because extending the exercise period post-retirement from 90 days to three years would result in a change in expected term, which would increase the fair value of the share options. The incremental compensation cost resulting from the modification should be recognized immediately for vested options and over the remaining requisite service period for unvested options.

Q&A 5.3a: Modification to Increase Exercise Period after Termination

Q. ABC Corp grants share options to senior management with terms that require the vested option to be exercised within 10 days of involuntary termination of employment from the company. The company subsequently modifies the option plan to extend the exercise period to 60 days after termination. The modification does not change the original contractual expiration term of 10 years for the options. The awards are probable of vesting both before and after the modification (therefore, a probable-to-probable modification). Does this modification have an accounting consequence?

A. It depends. If the probable-to-probable modification was made in contemplation of a specific employee termination event, the modification could result in an increase in the expected term of the terminated share options, resulting in an increase in the fair value of

the options. This is because the fair value before the modification would be based on an expected term for an option with a 10-day post-termination exercise period, while after the modification the fair value would be based on an expected term for an option with a 60-day post-termination exercise period. The incremental fair value resulting from the modification is recognized immediately as compensation cost for vested options and, for unvested options, it is recognized over the remaining requisite service period.

If the probable-to-probable modification was not made in contemplation of a specific employee termination event, the expected term, depending on the facts and circumstances, may or may not increase by 50 days. ABC would need to determine if the expected term changed, and if the change results in incremental fair value triggering modification accounting.

Q&A 5.3b Modifications That Occur Frequently

Q. Does an entity apply the share-based payment accounting model, and therefore, modification accounting to an award that is modified multiple times?

A. Generally, yes. However, frequent modifications of a share-based payment award may indicate that there is no mutual understanding of the award's key terms and conditions between the grantor and grantee. When a service inception date exists but a mutual understanding of the key terms and conditions does not exist, then the grant date and measurement date cannot be established and the award is recorded at its fair value at each reporting date until settlement. Also see Paragraph 4.036.

We believe frequent modifications generally will not automatically lead to the conclusion that there is no mutual understanding of the award's key terms and conditions. This belief is based on the FASB's rejection of a different accounting model for awards that are frequently modified as part of its deliberations of FAS 123(R). Specifically, the FASB explained in the Basis for Conclusions to FAS 123(R) that "[t]he Board considered several possible means of identifying awards to be accounted for as if a grant date has not yet occurred and concluded that each possible method could result in significant implementation problems." Moreover, the Board noted that most modifications "result in the recognition of incremental compensation cost." [FAS 123(R).BC200]

However, if it is apparent from the facts and circumstances that the initial terms of the award were provided as *place holders* to be modified in the future, we believe that a grant date would not occur until the date on which all the key terms and conditions are mutually understood.

MODIFICATIONS THAT AFFECT VESTING CONDITIONS

5.007 An award may be modified by changing its exercise price, extending its contractual term, or changing its vesting conditions. For share options, modifications that affect either

the exercise price (see Examples 5.1 and 5.2) or the contractual term (and as a result, the remaining expected term of the share option) affect the per share option fair value of the award.

5.008 A modification of an award's vesting terms does not affect an award's per share or per share option fair value. However, a modification to the vesting terms of an award may impact the total amount of compensation cost to be recognized as it is likely to result in either a Type I or Type III modification (see Paragraph 5.009a). As a result, when there is a change in vesting conditions only, an entity is required to consider the modification accounting guidance within ASC Topic 718. If, at the date of the modification, an award is expected to vest under its original service or performance condition (Type I, probable-to-probable, modification), total compensation cost is unchanged by a modification that only changes the vesting conditions (and the award is still expected to vest). However, if at the date of the modification, the award is not expected to vest under the original service or performance condition (Type III, improbable-to-probable, modification), total compensation cost is equal to the modified award's fair value at the date of the modification. This situation commonly arises when an employee is or will be terminated prior to the vesting of an award, the award terms do not provide for accelerated vesting upon termination, and the employer accelerates vesting to allow the employee to exercise or receive the award. In effect, the employee forfeited the original award (because the original award would have been forfeited on termination) and is granted a new, fully vested award. ASC paragraphs 718-20-55-107 and 55-108

5.009 We believe an entity should make a policy election about how it will apply modification accounting to awards when there is a modification to accelerate vesting. Under Alternative I, an entity views modification accounting as applying to each individual award, and attribution (which includes a forfeiture estimate, if the entity's accounting policy is to estimate the number of forfeitures) as applying to the population subject to modification. This results in a Type I modification for the entire modified award. Under Alternative II, an entity views both the modification and the attribution as applying to the population modified and therefore a modification may result in several different types of modifications (Type I, Type III, and Type IV as illustrated in Example 5.4 and 5.5). An entity that has an accounting policy to account for forfeitures when they occur in accordance with ASC paragraphs 718-10-35-3 is required to assess at the date of the modification whether the performance or service conditions of the original award are expected to be satisfied. The estimate of forfeitures related to the original award is required when there is a modification, since that estimate can affect the cumulative compensation cost to be recognized. However, an entity's policy election for forfeitures will apply when it subsequently accounts for the modified award.

5.009a The table below summarizes an entity’s accounting for compensation cost, depending on policy for forfeitures under the two alternatives for accounting for modifications. as discussed in Paragraph 5.009:

| Modification policy | Modification to accelerate vesting terms | If the entity’s accounting policy is to estimate forfeitures: Compensation cost consideration at time of modification | If the entity’s accounting policy is to account for forfeitures as they occur (see Example 5.7a): Compensation cost consideration at time of modification |
|---|---|--|--|
| Alternative I – modification accounting applies to each individual award (i.e., modification applies to all awards) | Type I – probable-to-probable for all awards | Calculate incremental compensation cost for all awards based on fair value before and after the modification; recognize incremental compensation cost over the remaining employee requisite service period or nonemployee vesting period, adjusted for estimated forfeitures. For modifications that only change vesting conditions, total compensation cost is unchanged for all awards, as there is no additional value upon modification. | Calculate incremental compensation cost for all awards based on fair value before and after the modification; recognize incremental compensation cost over the remaining employee requisite service period or nonemployee vesting period. For modifications that only change vesting conditions, total compensation cost is unchanged for all awards, as there is no additional value upon modification. After the modification, compensation cost is reversed at the |

| | | | |
|---|--|---|---|
| | | | time any forfeitures occur. |
| Alternative I – modification accounting applies to each individual award (i.e., modification applies to all awards) | Type III – improbable-to-probable for all awards | Cumulative compensation cost to be recognized over the remaining employee requisite service period or nonemployee vesting period is the fair value of the modified awards | Same approach as if entity’s policy is to estimate forfeitures. After the modification, compensation cost is reversed at the time any forfeitures occur. |

Under Alternative I, there are two scenarios that are most likely to occur in practice for a modification to accelerate vesting terms. The entity has either accelerated awards that were already probable of vesting (Type I), or has accelerated awards that were not probable of vesting (Type III), based on the original terms of the awards.

For entities that elect to account for forfeitures as they occur, under Alternative I, the cumulative compensation cost considerations are the same as if the entity had a policy to estimate forfeitures. This is because the entity applies the modification considerations to all the awards with the same approach, regardless of whether it was an award expected to be forfeited.

| | | | |
|---|--|--|--|
| Alternative II – modification accounting applies to the population modified (i.e., different types of modification for different populations of the same award) | Type I – probable-to-probable for population of the awards expected to vest, which would exclude awards included in Type III and Type IV below | Recognize incremental compensation cost for awards in the Type I population based on fair value before and after the modification; recognize incremental compensation cost over the remaining employee requisite service period or nonemployee vesting period, adjusted for estimated forfeitures. For modifications that only change vesting conditions, total compensation cost is | Recognize incremental compensation cost for awards in the Type I population based on fair value before and after the modification; recognize incremental compensation cost over the remaining employee requisite service period or nonemployee vesting period. For modifications that only change vesting conditions, total compensation |
|---|--|--|--|

unchanged for Type I awards, as there is no additional value upon modification

cost is unchanged for Type I awards, as there is no additional value upon modification.

After the modification, compensation cost is reversed at the time any forfeitures occur for awards in the Type I population.

| | | |
|---|---|--|
| <p>Type III – improbable-to-probable for population of the awards originally expected to be forfeited, but expected to vest due to the modification</p> | <p>Cumulative compensation cost to be recognized over the remaining employee requisite service period or nonemployee vesting period is the fair value of the modified awards in the Type III population, which may be higher or lower than the grant date fair value.</p> | <p>Cumulative compensation cost to be recognized over the employee remaining requisite service period or nonemployee vesting period is the fair value of the modified awards in the Type III population.</p> <p>Compensation cost for these awards prior to the modification is not reversed on the modification date. Any compensation cost recognized for these awards prior to the modification is compared to the fair value of the modified awards to determine total cumulative compensation cost to recognize for these awards; compensation cost</p> |
|---|---|--|

| | | |
|--|--|---|
| <p>Type IV – improbable-to-improbable for population of the awards originally expected to be forfeited before and after the modification</p> | <p>There is no additional compensation cost at the time of the modification for Type IV awards; If the awards become probable of vesting at a later date, recognize any additional compensation cost for awards expected to vest post-modification using the fair value on modification date, which may be higher or lower than the grant date fair value.</p> | <p>is reversed at the time any forfeitures in the Type III population actually occur.</p> <p>Cumulative compensation cost to be recognized over the remaining employee requisite service period or nonemployee vesting period is the fair value of the modified awards in the Type IV population.</p> <p>Compensation cost for these awards prior to the modification is not reversed on the modification date. Any compensation cost recognized for these awards prior to the modification is compared to the fair value of the modified awards to determine total cumulative compensation cost to recognize for these awards; compensation cost is reversed at the time any forfeitures in the Type IV population actually occur.</p> |
|--|--|---|

Under Alternative II, when there is a modification to accelerate vesting, the entity's awards, upon modification, are bifurcated into the different populations, depending on which scenario is applicable (Type I, Type III, or Type IV).

If the entity's accounting policy is to recognize forfeitures when they occur, additional compensation cost can arise, under Alternative II. This scenario exists when there are awards that were improbable of vesting prior to the modification, and the fair value of the awards at modification is greater than the original grant date fair value.

Modifications to nonemployee awards

The total amount of compensation cost recognized for share-based payment awards to nonemployees is based on the number of instruments for which a good has been delivered or a service has been rendered, also referred to as the nonemployee's vesting period. The determination of the nonemployee vesting period is made at the grant date (or the service inception date, if it precedes the grant date) based on an analysis of the service, performance, or market conditions (or a combination thereof) that are explicit, implicit, or derived in the terms of the award. The difference between a nonemployee vesting period and an employee requisite service period, is that the nonemployee compensation cost is attributed over the vesting period in the same manner as it would be if the grantor had paid cash for the goods or services instead of granting share-based payment awards. As a result, for modifications that accelerate vesting, compensation cost attribution for nonemployee awards may not necessarily be the same as for employee awards. When unvested nonemployee awards are modified, any additional compensation cost for nonemployee awards would be recognized over an attribution period that is as if the grantor paid cash instead of issuing share-based payment awards.

Example 5.3: Modification to Accelerate Unvested Share Options on Termination

On January 1, 20X6, ABC Corp. grants its CEO 100,000 share options with an exercise price of \$15 per share option (which equals the current share price). The award cliff vests after four years of service. The grant-date fair value is \$5 per share option. As a result, ABC would recognize compensation cost of \$125,000 per year ($100,000 \times \$5 / 4$ years) over each of the next four years assuming the CEO continues to provide service.

At the end of 20X7, ABC's Board of Directors terminates the CEO. Under the original terms of the awards, the share options all would have been forfeited. However, as part of the severance package, the Board agreed to immediately vest all of the CEO's share options and allow them to remain exercisable for the next two years.

Based on a current share price of \$25 and an expected term of two years,¹ the fair value of the modified award is \$12 per share option. At the date of the modification, the service condition of the original award would not be satisfied because the CEO was terminated before completing the four-year service condition of the original award.

Therefore, the cumulative compensation cost to be recognized is the fair value of the modified award of \$1,200,000 (100,000 × \$12).

Because the award is fully vested, ABC would recognize the following amount (assuming compensation cost for 20X7 for the original awards had already been recognized):

| | |
|--|------------------|
| Fair value of modified award | \$ 1,200,000 |
| Less: Compensation cost recognized in 20X6 and 20X7 | <u>(250,000)</u> |
| Compensation cost to recognize at the time of the modification | \$ 950,000 |

¹ The expected term of the modified award is two years because the remaining contractual term of the share option is not dependent on the CEO's continued employment.

Q&A 5.4: Acceleration of Vesting on Termination

Q. On termination, an entity accelerates the vesting of an award that would have otherwise been forfeited. Can the final amount of compensation cost be less than the grant-date fair value of the award?

A. Yes. Because the service or performance condition of the original award will not be satisfied (the employee will not render the requisite service), any previously recognized compensation cost for the original award is reversed at the modification date. The fair value of the modified award is recognized immediately because it is considered a new award that is fully vested. If the entity's share price has declined since the grant date of the original award, the fair value of the modified award may be lower than the grant date fair value of the original award. Therefore, the cumulative compensation cost would be less than the grant-date fair value of the original award. Statement 123(R), par. B190

Q&A 5.5: Acceleration of Vesting on Involuntary Termination

Q. The original terms of an award provide that if an employee is terminated without cause, any unvested awards are immediately vested. On termination, is the acceleration of unvested awards considered a modification?

A. No. A condition that results in the acceleration of vesting in the event of an employee's death, disability, or termination without cause is a service condition. As a result, the acceleration on such an event would not be considered a modification because the service condition of the original award would have been met. The remaining unrecognized compensation cost would be recognized at the date of the employee's death, disability, or termination without cause. ASC Section 718-10-20

Q&A 5.6: Modification That Affects Vesting and Grant Date – Part I

Q. What is the accounting effect if a company grants a nonvested share award that vests on the achievement of a specified EPS target and the company subsequently modifies the terms of the awards to include a requirement that the awards will not vest unless the compensation committee determines that in addition to achieving the EPS target, the company's overall growth has been satisfactory?

A. On modification, the awards no longer have a grant date because the requirement of a subjective assessment of overall growth does not lend itself to there being a mutual understanding of the key terms and conditions of the award. In this situation, the modification effectively rescinds the previously established grant date resulting in the service inception date preceding the grant date. Therefore, the awards previously granted by the company will be marked to fair value each reporting period until the compensation committee decides that the company's overall growth has been satisfactory (i.e., a new grant date is established). On the date of modification, the company will record an adjustment in compensation cost to *true up* to the fair value of the award at each reporting date and the compensation cost will continue to be adjusted until a new grant date is established (see Paragraph 4.037).

Q&A 5.6a: Modification That Adds Early Exercise Feature to Share Options - Part II

Background

In January 20X2, ABC Company added a new provision to its previously granted employee share options. The new provision provides for the following:

- Participants may at any time exercise all or any part of their share options before they are fully vested; and
- In the event the participant voluntarily terminates employment, the Company has the right to repurchase (i.e., an employer call option) any unvested shares received by the participant as a result of the share options exercised. The repurchase feature has a strike price of the lesser of the fair value of the shares at the repurchase date or the original exercise price, and is only exercisable by the Company if the participant voluntarily terminates employment before the end of the vesting period. At the completion of the original requisite service period for the share options, the repurchase feature lapses.

The early exercise feature affords the employees potentially favorable tax consequences upon the subsequent sale of the shares.

Effect of the Modification on Attribution. The new provision added to the share options to permit early exercise and to establish a repurchase feature does not change the requisite service period. The repurchase feature essentially functions as a forfeiture provision for the award because the participant is not entitled to the rewards of ownership prior to the satisfaction of the requisite service. That is, the employee will lose any appreciation on the stock that occurs between the date of early exercise and the original vesting date if the employee departs from the company.

Effect of the Modification on Classification. Because the repurchase feature functions as a forfeiture provision, it does not impact the classification of the award.

Effect of the Modification on Fair Value. The modification does not affect the fair value of the award for accounting purposes. The potential tax benefits to the individual holder is not a component in determining fair value of share-based payments. In addition, there is a potential reduction in fair value. While the share options have been early exercised for accounting purposes, this is not considered a substantive exercise until the requisite service is rendered. Therefore, the expected term of the modified share options will be the remaining requisite service period and, in most circumstances, the expected term of the share options just prior to modification would assume a holding period after vesting before the share options are exercised. The shortening of the expected term results in a reduction of fair value under the Black-Scholes valuation model. Reductions in fair value are not recognized for probable-to-probable (Type I) modifications.

- (a) **Accounting.** - The early exercise of the share options is not considered to be a substantive exercise for accounting purposes because the exercise also activates the repurchase provision. Therefore, the shares received by the employee are not *issued* until those shares vest. Vesting occurs when the employer call option lapses and the employee has all the risks and rewards of ownership. The shares are excluded from basic EPS until the employer call option lapses and the shares are no longer contingently returnable (see section 6.10 in KPMG Handbook, Earnings per share). The Company also continues to recognize compensation cost based on the grant date fair value of the awards with an offset to equity. The cash paid for the exercise price is recorded as a deposit liability. The subsequent accounting depends on the facts and circumstances as follows: If the employee terminates before the requisite service is completed and the Company exercises the repurchase feature, the share option is deemed to have been forfeited. As a result of the forfeiture, the previously recognized compensation cost is reversed, considering the entity's accounting policy for forfeitures and the repayment reduces the deposit liability.

If the repurchase was at the market price of the stock at the repurchase date, the difference in the market price of the stock at the date of departure and the exercise price of the stock option is recognized as an offset to additional paid-in capital.

- (b) If the employee terminates before the requisite service is completed but the Company decides not to exercise the repurchase feature, then an improbable-to-probable modification of the share options to accelerate vesting has occurred followed by an immediate exercise of the awards. The accounting for the modification would be similar to the accounting described in Example 5.3, and the deposit liability is reclassified into additional paid-in capital (APIC).

Q&A 5.7: Acceleration of Vesting of Out-of-the-Money Share Options

Background

Substantially all of an entity's outstanding employee share option awards are currently out-of-the-money as a result of significant deterioration in the entity's stock price. The entity is considering accelerating vesting of all outstanding awards. Under the plan being considered, the entity would not grant or promise to grant additional awards to the affected employees.

Q. How should the entity account for the acceleration of vesting of its out-of-the-money share options that are not accompanied by grants (or promises to grant) additional at- or near-the-money share options or other share-based payment awards?

A. It depends in the first instance on a judgment about whether the share options are *deep* out-of-the-money at the time the awards are modified. If the awards are determined to be deep out-of-the-money at the date of the acceleration, then the acceleration would be viewed as nonsubstantive. This is in accordance with ASC paragraph 718-10-55-67, which states "Likewise, if an award with an explicit service condition that was at-the-money when granted is subsequently modified to accelerate vesting at a time when the award is *deep* out-of-the-money, that modification is not substantive because the explicit service condition is replaced by a derived service condition" (emphasis added). However, if the awards are determined to be out-of-the-money but not *deep* out-of-the-money, then the modification could be viewed as substantive. There are several factors to consider in making a judgment about whether share options are *deep* out-of-the-money and, if not, there are various views applied in practice to account for the modified awards.

Evaluating whether awards are deep out-of-the-money. As discussed in Paragraph 4.059, there is no bright-line test that indicates when an out-of-the money grant is deemed to be deep out-of-the-money. Therefore, all facts and circumstances related to the share options should be evaluated.

In some cases, a qualitative assessment is sufficient to support a conclusion that an award is deep out-of-the money. For instance, if the exercise price of a share option is \$30 and the current market price is \$3, the disparity is so significant that a qualitative assessment is sufficient to conclude that the award is deep out-of-the money. In other situations, a qualitative assessment may not be sufficient to support such a conclusion. For example, if the exercise price of a share option is \$30 and the current market price is \$20, it may not be clear whether the award is deep out-of-the-money. In those situations, we believe that

there are quantitative techniques that can be used to support the judgment of whether the award is deep out-of-the-money.

For example, a Monte Carlo simulation, which typically is used to compute a derived service period for awards with market conditions (including deep out-of-the-money share options), could be used to evaluate whether a share option is deep out-of-the-money. For this analysis, the estimated period until market recovery would be the derived service period computed using a Monte Carlo simulation. As described in Paragraph 4.071, the derived service period is the median path of all paths in the simulation that result in the stock price exceeding the target price (in this case the exercise price).

If the ratio of the estimated period until market recovery to the remaining requisite service period is less than approximately half of the remaining requisite service period, we generally believe the share option would *not* be viewed as being deep out-of-the-money. If the ratio is more than approximately half of the remaining requisite service period, we generally believe the share options *would* be viewed as being deep out-of-the-money. The analysis should be performed on a grant-by-grant basis for all of a company's outstanding awards that are subject to the notional acceleration. If an entity has multiple tranches of affected awards, we believe that the objective should be to achieve a cutoff between awards that are deemed to be deep out-of-the-money at a ratio of approximately 50%. However, we believe that all of the affected awards should be evaluated together and it may be appropriate for the cutoff to be above or below the 50% target if that results in a natural delineation within the overall population. This decision is a judgment to be made in particular sets of facts and circumstances.

For purposes of illustration, assume that awards were issued at various dates during 20X6 - 20X8 with a four-year requisite service period. At the time of the modification, the number of remaining months in the original requisite service periods, the derived service period, and analysis under potential scenarios is as follows:

| | Computed Derived Service Period | Remaining Original Requisite Service Period | Ratio | Preliminary Assessment |
|---------|--|--|--------------|-----------------------------------|
| Award A | 6 months | 24 months | 25% | Not deep out-of-the-money |
| Award B | 13 months | 36 months | 36% | Not deep out-of-the-money |
| Award C | 8 months | 17 months | 47% | Facts & circumstances |
| Award D | 15 months | 20 months | 75% | Deep out-of-the-money |
| Award E | 16 months | 8 months | 200% | Deep out-of-the-money |

The initial conclusion would be that Awards A and B are not deep out-of-the-money and that Awards D and E are deep out-of-the-money. Given that the ratio for Award C is near 50% and there is a natural delineation for the next closest award, it would be reasonable to conclude that the Award C is not deep out-of-the-money. Because Awards D and E are considered to be deep out-of-the-money, the acceleration is deemed to be nonsubstantive and the unrecognized compensation cost for those awards would continue to be recognized over the original requisite service period.

Accounting for awards not considered to be deep out-of-the-money. There are several acceptable methods in practice to account for awards that are not considered to be deep out-of-the-money resulting in a conclusion that the modification is substantive.

Some believe that the notional acceleration for those awards is substantive and, therefore, any remaining unrecognized compensation cost should be recognized at that time. If this view were applied to the example described above, any remaining unrecognized compensation cost for Awards A, B, and C would be recognized on the date of the modification.

Others believe that the modification results in the replacement of an award containing a service condition (the original award) with an award containing a market condition. Under this view, the derived service period of each award should be used as the remaining requisite service period. If this view were applied to the example described above, any remaining compensation cost for Awards A, B, and C would be recognized over 6 months, 13 months, and 8 months, respectively. (As indicated below, the SEC staff is inclined to take this view when the derived service period is a substantive period of time; generally, those periods approaching two years or more.)

Other considerations. For awards for which compensation cost is not accelerated (i.e., where the modification is deemed to be a replacement award containing a market condition), it is possible that the market price for the company's shares could recover and the awards exercised before the end of the requisite service period (i.e., the derived service period). Consistent with the requirements of ASC Topic 718 for awards with a market condition, if the stock price recovers such that it equals the exercise price prior to the end of the derived service period, then any remaining unrecognized compensation cost should be accelerated at that time.

In addition to the ratio described above, the SEC staff has informally indicated that they believe that if the derived service period is a substantive period of time, despite being a relatively low ratio of the remaining requisite service period, full acceleration of the associated compensation cost may not be acceptable. For example, if the derived service period is two years and the remaining requisite service period is five years, the award would not be considered to be deep out-of-the-money following the model described above. However, we understand that the SEC staff believes that notwithstanding a ratio of 40% (2 years / 5 years), the two-year continued service requirement is so significant that accelerating the compensation charge would not be appropriate. In these situations, the SEC staff would expect companies to recognize compensation cost either over the

derived service period of two years or over the original remaining requisite service period of five years.

Q&A 5.7a: Modification When an Entity's Accounting Policy Is to Account for Forfeitures as They Occur

Background

An entity that has an accounting policy to account for forfeitures as they occur assesses, at the date of the modification, whether the performance or service conditions of the original award are expected to be satisfied when measuring the effects of the modification in accordance with ASC paragraph 718-20-35-3. Assuming that the estimated forfeitures is 10% before and 5% after the modification, how does an entity account for the modification prospectively?

Alternative I. Under Alternative I, an entity views modification accounting as applying to each individual award, and attribution as applying to the population subject to modification. This results in a Type I modification for the entire modified award.

Because the company has an accounting policy to recognize forfeitures as they occur and has been recognizing 100% of the expense, and the modification does not change the vesting terms, immediately prior to the modification the company assumes that all awards are Type I (probable to probable). The company would perform the assessment of whether there is incremental compensation (using the fair value immediately before and after the modification) and recognize incremental compensation for all awards over the remaining requisite service period, or vesting period, if the award is a nonemployee award. Compensation cost would be reversed at the time the forfeitures occur.

Alternative II. Under Alternative II, an entity views both the modification and the attribution as applying to the population modified and therefore a modification may result in several different types of modifications (Type I, Type III, and Type IV). Although the modification does not change the vesting terms of the award, there is a Type I (probable-to-probable) modification for 90% of the awards, a Type III (improbable-to-probable) for 5% of the awards, and a Type IV (improbable-to-improbable) modification for 5% of the awards. The 5% of the awards that fall into the Type III category and the 5% of the awards that fall into the Type IV category will have a new measurement date and the Company will use the fair value on the modification date to recognize compensation cost. Because the accounting policy is to account for forfeitures as they occur, the new fair value will be used to recognize compensation cost for the 10% (5% + 5%) such that at the end of the vesting period, cumulative compensation cost equal to the number of awards that vest multiplied by the modification date fair value would be recognized. The company would perform the assessment of whether there is incremental compensation (using the fair value immediately before and after the modification) and recognize incremental compensation for the 90% over the remaining requisite service period, or

over the vesting period, if the award is a nonemployee award. Compensation cost would be reversed at the time the forfeitures actually occur.

Example 5.4: Acceleration of Vesting of a Service Condition – Alternative I

On January 1, 20X6, ABC Corp. grants 100 nonvested shares to each of its 1,000 employees that cliff vest after five years of service. The grant-date fair value of each nonvested share is \$10. ABC's accounting policy is to estimate the number of forfeitures and to include that estimate in its initial accrual of compensation costs. Based on historical employee turnover rates, ABC estimates that 200 employees will terminate service prior to completing the five-year requisite service period. At the beginning of 20X8, ABC accelerates the vesting of all of the awards so that vesting occurs after four years of service rather than the original five-year service period. As a result of the acceleration, ABC now expects that only 150 employees will forfeit their awards. ABC has elected a policy to view modification accounting as applying to each of the individual awards and attribution as applying to the population subject to modification (Alternative I as described in Paragraph 5.009), which results in a Type I modification for the entire population for which the award is modified.

ABC would recognize compensation cost as follows:

Years 20X6 and 20X7

| | | |
|-----------------------------------|---|-----------|
| Number of shares expected to vest | | 80,000 |
| Fair value per nonvested share | × | \$10 |
| Total compensation cost | | \$800,000 |
| Requisite service period | / | 5 years |
| Compensation cost per year | | \$160,000 |

Years 20X8 and 20X9

| | | |
|---|---|-----------|
| Revised number of shares expected to vest | | 85,000 |
| Fair value per nonvested share | × | \$10 |
| Total compensation cost | | \$850,000 |
| Requisite service period after modification | / | 4 years |
| Revised compensation cost per year | | \$212,500 |
| | × | 3 years |
| Cumulative compensation cost through 20X8 | | \$637,500 |
| Less: Compensation cost recognized in 20X6 and 20X7 | | \$320,000 |
| Compensation cost recognized in 20X8 | | \$317,500 |
| Compensation cost recognized in 20X9 | | \$212,500 |

Accelerating the vesting condition does not cause a change in the grant-date fair value of the award. However, because of the acceleration of the vesting period, the number of nonvested shares expected to vest increased. Changes in actual or estimated outcomes that affect the quantity of instruments for which the requisite service is expected to be

rendered are accounted for using a cumulative adjustment approach. ASC paragraphs 718-10-55-78 and 55-79

Example 5.4a: Acceleration of Vesting of a Service Condition – Alternative II

Assume the same facts as in Example 5.4, except that ABC Corp. has elected a policy to apply modification accounting to the population of awards modified (Alternative II as described in Paragraph 5.009). The fair value of the nonvested shares on the modification date is \$15.

The acceleration of the vesting results in three types of modifications: (1) Type I modification of the 80,000 awards (800 employees × 100 nonvested shares) for which vesting was considered probable under the original terms and at the modification date; (2) Type III modification of the 5,000 awards ([200 employees expected to forfeit awards – 150 employees now expected to forfeit awards] × 100 nonvested shares) for which forfeiture was expected under the original terms but is no longer expected as a result of the modification; and (3) Type IV modification for the 15,000 shares (150 employees expected to forfeit before and after the modification × 100 nonvested shares) that were expected to be forfeited before the modification and for which ABC still expects awards to be forfeited.

Compensation cost under this scenario is as follows after the modification (compensation cost in 20X6 and 20X7 is the same as in Example 5.4):

Years 20X8 and 20X9

| | | | |
|----------|--|---|-----------|
| Type I | Cumulative compensation cost through 20X8 for 80,000 shares (\$160,000 × 2) | | \$320,000 |
| | Remaining unrecognized compensation cost (\$800,000 - 320,000), recognized over modified two-year service period | | \$480,000 |
| | Compensation cost recognized in 20X8 and 20X9 | | \$240,000 |
| Type III | Revised number of shares expected to vest | | 5,000 |
| | Fair value per nonvested share at modification date | × | \$15 |
| | Additional compensation cost, recognized over modified two-year service period | | \$75,000 |
| | Compensation cost recognized in 20X8 and 20X9 | | \$37,500 |
| Type IV | Revised number of shares not expected to vest | | 15,000 |
| | Fair value per nonvested share at modification date | × | \$15 |
| | Additional compensation cost | | \$0 |

Accelerating the vesting condition does not cause a change in the fair value of the 80,000 shares originally expected to vest and still expected to vest after the modification. For the Type III modifications, the fair value at the date of the modification is used. No compensation cost is recognized for the Type IV modification because those shares were not expected to vest before or after the modification. However, if ABC's estimate changes such that all or a portion of the Type IV awards are expected to vest, ABC would recognize compensation cost of \$15 per share for those awards.

If ABC's policy is to account for forfeitures as they occur and it elects Alternative II when accounting for modifications of awards, compensation cost recorded for the Type I modification of the 80,000 awards would be the same as above. However, for the Type III and Type IV modifications above, the awards would have a new measurement date and ABC would use the \$15 fair value on the modification date to recognize compensation cost. Because the accounting policy is to account for forfeitures as they occur, the new fair value will be used to recognize compensation cost for the awards (i.e., 5,000 plus 15,000 awards). As the fair value for awards increased from \$10 to \$15, ABC would recognize incremental compensation for the 80,000 awards over the remaining requisite service period. Compensation cost would be reversed at the time the forfeitures actually occur. That is, at the time of modification, ABC would record a cumulative catch-up adjustment for the increase in fair value for the Type III and Type IV awards, when Alternative II is used by ABC. See Paragraph 5.009a.

Example 5.5: Type III Modification With Initial Estimated Forfeiture Rate of 0% or When A Company Accounts for Forfeitures When They Occur

On January 1, 20X5, ABC Corp. grants 100,000 nonvested shares to its CEO that cliff vest after five years of service. Before vesting, the awards are forfeited if the CEO is terminated for any reason. ABC's policy is to estimate forfeitures and ABC has estimated a zero forfeiture rate for these awards.

On December 21, 20X6, ABC's Board of Directors decides to terminate the CEO's employment during the first quarter of 20X7. On January 15, 20X7, the Board of Directors informs the CEO of its decision, which is effective February 28, 20X7.

Since it was determined on December 21, 20X6 that the CEO would be terminated, in connection with the preparation of its financial statements as of and for the period ending December 31, 20X6, ABC updates its estimate of forfeitures as of December 31, 20X6 to reflect an expectation that 100% of the awards will be forfeited. As a result of updating this forfeiture estimate, ABC reverses all previously recognized compensation cost associated with these awards when preparing the financial statements as of and for the year ended December 31, 20X6.

Subsequent to January 15, 20X7 and prior to the issuance of ABC's December 31, 20X6 financial statements, the Board of Directors negotiates with the CEO to modify the terms of the award for the 100,000 nonvested shares to allow for immediate vesting on

employment termination. ABC evaluates the modification made to the awards, as a result of the negotiations with the CEO, and concludes that it is a Type III modification (improbable-to-probable). As a result, ABC recognizes compensation cost in the 20X7 financial statements for the modified awards based on the fair value of the 100,000 nonvested shares on the modification date. The Type III modification is recorded in the 20X7 financial statements, as the modification date is in 20X7. However, disclosure in the 20X6 financial statements of both the change in estimated forfeiture rate and the 20X7 modification would need to be made, if material.

Alternatively, if ABC had an accounting policy to account for forfeitures as they occur, the forfeiture and modification of the CEO's nonvested shares are both accounted for in the 20X7 financial statements.

If ABC accounts for forfeitures as they occur, ABC would have two alternatives in accounting for the modification of the CEO's nonvested shares. In the first alternative, the previously recognized compensation cost would be reversed on the date of the modification and the fair value of the modified award would then be recognized over the remaining substantive service period. In the second alternative, the difference between the modification date fair value of the nonvested shares and the previously recorded compensation expense would be recognized over the remaining substantive service period. Further consideration of whether disclosure of the modification as a subsequent event is also required in this scenario.

To the extent that the second alternative is elected and the fair value of the awards on the modification date is less than the award on the original grant date fair value of the award, we believe ABC could choose to either recognize a cumulative catch-up adjustment on the date of modification or recognize the difference over the remaining substantive service period. ABC would need to apply the accounting policy elections consistently to all modified awards.

See Paragraphs 4.062 and Appendix I, Paragraph 10.045 for further discussion on substantive vs. nonsubstantive service periods.

MODIFICATIONS THAT AFFECT VESTING CONDITIONS AND FAIR VALUE

5.010 In some situations, an entity may modify an award to change both its vesting conditions and the award's fair value. This situation may occur, for example, when an entity reprices a fully vested, out-of-the-money share option. In return for repricing of the share option, the entity may establish a new service or vesting period so that the grantees can earn the repriced share option. Because the original award is fully vested at the time of the modification, the grant-date fair value of the original award was previously recognized as compensation cost and would not be reversed. In accounting for the modification, the incremental fair value of the award calculated at the date of the modification would be recognized over the newly established service or vesting period of the modified award. The incremental compensation cost would be recognized only for grantees who satisfy the

employee's requisite service period or nonemployee's vesting period of the modified award with forfeitures recognized in accordance with the entity's accounting policy as described in Paragraph 4.003.

Example 5.6: Modification of Fully Vested Share Options That Affects Vesting and Fair Value

On January 1, 20X6, ABC Corp. grants 20,000 share options with an exercise price of \$10 per share option (the current share price). The awards cliff vest after three years of service. The grant-date fair value is \$4 per share option. None of the awards were forfeited. Therefore, ABC recognized compensation cost of \$80,000 (20,000 share options × \$4) over the three-year employee requisite service period.

On March 31, 20X9, after the share options are vested, ABC decides to reduce the exercise price of the share options to \$3 (i.e., a repricing of the awards), which equals the current share price. The repriced share options cliff vest after two additional years of rendering service. The fair value of the modified award is \$1.20 per share option. The fair value of the original award at the date of the modification is \$0.50 per share option (with an exercise price of \$10, the share options are deep out-of-the-money).

The incremental compensation cost for the modification is as follows (assumes that no share options have been exercised):

| | | |
|---|---|-----------------|
| Fair value of modified share option at March 31, 20X9 | | \$1.20 |
| Less: Fair value of original share option at March 31, 20X9 | | (0.50) |
| Incremental compensation cost per share option | | <u>\$0.70</u> |
| Number of awards modified | × | 20,000 |
| Incremental compensation cost | | <u>\$14,000</u> |

Assume that ABC's accounting policy is to estimate the number of forfeitures and to include that estimate in its initial accrual of compensation cost. ABC estimates that over the two-year vesting period, 1,000 share options will be forfeited and that actual forfeitures equal expected forfeitures. As a consequence, 95% of the modified awards are expected to vest (19,000 share options / 20,000 share options). Therefore, additional compensation cost of \$13,300 (\$14,000 × 95%) is recognized over the two-year service period.

5.011 Likewise, a modification may occur in connection with repricing of an out-of-the-money unvested share option, in which an employee agrees to a longer vesting period in exchange for a repriced share option. When modifications occur during the vesting period, there is mixed practice in attributing the compensation cost over the revised employee's requisite service period when that period is longer than the remaining portion of the original employee's requisite service period. Some entities separately account for the incremental fair value computed for the modification and recognize that amount over the total remaining employee's requisite service period with any remaining amount of unamortized compensation cost from the original award recognized over the remaining

portion of the original employee's requisite service period. Other entities do not bifurcate the amounts and recognize the total amount of remaining unrecognized compensation cost (based on the grant-date fair value) and the incremental fair value of the modified award, over the extended vesting period (this is the accounting that entities follow when the revised employee's requisite service period is the same as or shorter than the remaining portion of the original employee's requisite service period). Based on the discussion with the FASB Statement 123(R) Resource Group and FASB staff, this is considered an accounting policy election for employee awards that should be applied consistently with appropriate disclosures if material. If this scenario applied to nonemployee awards, we believe the ability to either separately account for the awards, or recognize the awards in total would also apply for nonemployee awards, with the compensation cost recognized as if the grantor had paid cash and over the corresponding vesting period.

Example 5.7: Modification of Unvested Share Options That Affects Vesting and Fair Value

On January 1, 20X6, ABC Corp. grants 15,000 share options with an exercise price of \$10 per share option (the current share price). The awards cliff vest after three years of service. The grant-date fair value is \$4 per share option. ABC's accounting policy is to estimate the number of forfeitures and to include that estimate in its initial accrual of compensation cost. ABC's initial estimate is that none of the awards are expected to be forfeited and through the modification date, no awards have been forfeited.

On January 1, 20X8, ABC reduced the exercise price of the share options to \$3, which equals the share price at the date of the modification. In exchange for the reduction in exercise price, ABC increased the vesting term from the original vesting period to three years from the date of modification (one year remaining from original vesting requirement and additional two years). The fair value of the modified award is \$1.20 per share option and the fair value of the original award at the date of the modification is \$0.50 per share option. Assume that ABC now estimates that over the three-year additional vesting period, 3,000 share options will be forfeited – 1,000 before the end of the original vesting period and 2,000 after the original vesting date but before the new vesting date. Assume that actual forfeitures equal expected forfeitures.

Assuming that ABC elects to separately account for the incremental compensation cost related to the modification and the original compensation cost, the amounts recognized in 20X8 and in 20X9 and 20Y0 would be as follows:

Compensation cost associated with the modification

| | |
|--|------------------|
| Fair value of modified share option at January 1, 20X8 | \$1.20 |
| Less: Fair value of original share option at January 1, 20X8 | <u>(0.50)</u> |
| Incremental compensation cost per share option | \$0.70 |
| Number of awards modified (expected to vest) | × <u>12,000</u> |
| Incremental compensation cost to be recognized | \$8,400 |
| Requisite service period | / <u>3 years</u> |
| Incremental compensation cost related to modification to be recognized in 20X8 | \$2,800 |

Compensation cost associated with the original award

| | |
|--|-------------------|
| Total compensation cost associated with the original award (14,000 share options expected to vest × \$4) | \$56,000 |
| Total compensation cost recognized before modification (15,000 share options × \$4 × 2/3) | <u>\$(40,000)</u> |
| Compensation cost to be recognized in 20X8 | \$16,000 |
| Portion of incremental compensation related to modification to be recognized in 20X8 (from above) | <u>\$2,800</u> |
| Total compensation cost to be recognized in 20X8 | \$18,800 |
| Total remaining compensation cost to be recognized (\$8,400 - \$2,800) | \$5,600 |

The remaining compensation cost of \$5,600 is recognized ratably over 20X9 and 20Y0 (the remaining requisite service period).

Alternatively, if ABC elects not to bifurcate the amounts but to recognize the total amount of remaining unrecognized compensation cost (based on the grant-date fair value) and incremental fair value of the modified award, over the extended vesting period, the calculation is illustrated below:

| | |
|--|--------------|
| Unrecognized compensation from original award | \$16,000 |
| Incremental compensation cost | <u>8,400</u> |
| Total compensation to be recognized over a new three-year period | \$24,400 |

In years 20X8, 20X9, and 20Y0, ABC will recognize compensation of \$8,133 (\$24,400 / 3 years) per year.

However, under this policy election, if fewer than 1,000 share options are forfeited by the end of 20X8 (the original vesting date), compensation cost is adjusted so that the grant-date fair value of the original awards is recognized on the share options for which the original three-year requisite service period is completed.

If ABC's accounting policy instead was to account for forfeitures when they occur, ABC is required to assess at the date of the modification whether the service conditions of the original award are expected to be satisfied by the end of 2008 (the original vesting date). The estimate of forfeitures related to the original award is required, when there is a modification, since that estimate can affect the cumulative compensation cost to be recognized. However, an entity's policy election for forfeitures will apply when it subsequently accounts for the modified award. See Paragraphs 5.009 and 5.009a for further discussion.

While this example scenario is for employee awards, its guidance also applies to nonemployee awards, other than for the compensation cost attribution. Nonemployee award compensation cost is recognized over a vesting period, and it is recognized in the same manner as if the grantor had paid cash. See Paragraph 4.086a.

MODIFICATIONS THAT AFFECT TRANSFERABILITY

5.012 The terms of a share-based payment award often restrict the transfer of an award to anyone other than the grantee. In certain situations, an award may be modified to allow for the transfer of the award to an immediate family member, family partnership, family trust, or others after the date of grant. If an award is modified to allow for its transfer, an entity should evaluate the effects of the change in the transferability restrictions based on the facts and circumstances to determine whether the modification of the transferability feature affects the exercise behavior of the holders of the award, which could affect the expected term of the award thereby resulting in incremental changes in fair value of the award. A modification to provide transferability that is limited to immediate family members, a family partnership, or family trust is likely to have minimal effect on the exercise behavior and the expected term because the expected exercise behavior of the grantee's family members may be no different than the expected exercise behavior of the grantee. Conversely, the ability to transfer the award to other parties is more likely to result in exercise behavior that is more similar to share optionholders unrelated to the company and therefore, the expected return may be closer to the contractual term of the option thereby resulting in incremental value due to the increased time value element of the award.

5.013 An entity also should consider whether the modification to the transferability feature affects its ability to use the simplified method under ASC paragraph 718-10-S99-1 for estimating the expected term, if applicable. The simplified method is appropriate for those awards that do not allow for transferability. Paragraphs 2.025 through 2.030 provide additional discussion of the simplified method.

MODIFICATIONS THAT AFFECT PERFORMANCE CONDITIONS

5.014 The accounting for the modification of the vesting condition of an award that vests on the achievement of a performance condition depends on the probability of achievement of the original performance condition immediately before and after the award is modified. At the date of the modification, both the original performance condition and the modified performance condition are assessed as either *probable* or *not probable*. If, at the date of the modification, it is probable that an award would vest under its original performance condition, compensation cost should be recognized using the grant-date fair value if *either* (1) the award vests under the modified vesting condition *or* (2) the award would have vested under the original vesting condition. Conversely, if, at the time of the modification, it is not probable that the award would vest under its original performance condition, compensation cost should be recognized only if the award vests under the modified vesting condition. ASC paragraphs 718-20-55-107 and 55-108

5.015 Therefore, at the date of the modification, the likelihood that the original award would vest under its original terms is assessed as being either probable or not probable. Likewise, at the date of the modification, the likelihood that the modified award will vest under its terms is assessed as being either probable or not probable. As such, there are four possible combinations and, therefore, four types of modifications that may occur for performance vesting conditions as illustrated in Example 5.8. Based on the outcome of the performance condition, Example 5.8 summarizes whether compensation cost should be recognized based on either (1) the grant-date fair value of the original award or (2) the fair value of the modified award. ASC paragraphs 718-20-55-107 through 55-109

Example 5.8: Modification of Performance Conditions

| | Probable to Probable (Type I) | Probable to Not Probable (Type II) | Not Probable to Probable (Type III) | Not Probable to Not Probable (Type IV) |
|---|--|---|--|---|
| Achievement of modified target | Grant-date fair value | Grant-date fair value | Fair value of modified award | Fair value of modified award |
| Achievement of original target, but not modified target | Grant-date fair value ¹ | Grant-date fair value ¹ | N/A | N/A |
| Achievement of original and modified target | Grant-date fair value | Grant-date fair value | Fair value of modified award | Fair value of modified award |

| | | | | |
|--|----------------------|----------------------|----------------------|----------------------|
| Neither the modified nor original target is achieved | No compensation cost | No compensation cost | No compensation cost | No compensation cost |
|--|----------------------|----------------------|----------------------|----------------------|

¹ This possible outcome could occur only when the modification makes an award less likely to vest. In this situation, the award would not vest because the modified target was not met. However, compensation cost (based on grant-date fair value) would still be recognized because the original performance target was met. We would expect these scenarios to be infrequent because generally a grantee would need to consent to a modification that makes an award less likely to vest.

Example 5.9: Modification of Performance Condition – Not Probable to Probable

On January 1, 20X6, ABC Corp. grants 10,000 share options with an exercise price of \$10 per share option (which equals the current share price) to each of its six regional sales managers. The share options vest if ABC's market share for its new product line equals or exceeds 20% at the end of three years. The grant-date fair value is \$3 per share option. ABC's accounting policy is to estimate the number of forfeitures and to include that estimate in its initial accrual of compensation cost. ABC does not expect any forfeitures.

Based on its forecasts, ABC estimates that the market share target is not probable of achievement and, therefore, recognizes no compensation cost for these awards. On January 1, 20X8, ABC lowers the market share target to 15% to motivate its regional sales managers. No other terms or conditions of the original award are changed. As a result of its share price increasing to \$12, the fair value of the award is \$6 per share option at the date of the modification. Immediately prior to the modification, no cumulative compensation cost has been recognized because the original market share target was not probable of achievement. ABC estimates that the new market share target is probable of achievement. Therefore, ABC will recognize compensation cost of \$360,000 ($\$6 \times 60,000$ share options) during 20X8.

While this example scenario is for employee awards, its guidance also applies to nonemployee awards, other than for the compensation cost attribution. Nonemployee award compensation cost is recognized over a vesting period, and it is recognized in the same manner as if the grantor had paid cash. See Paragraph 4.086a.

Example 5.9a: Modification of Performance Condition – Not Probable to Probable

Assume the same fact pattern as Example 5.9, but instead ABC revises its share target from 20% to 15% on January 1, 20X7 and the fair value of the original award is unchanged at \$3 per share. No other terms or conditions of the original award are changed.

Immediately prior to the modification, no cumulative compensation cost has been recognized because the original market share target was not probable of achievement. ABC estimates that the new market share target is probable of achievement. The cumulative compensation cost to be recognized over the remaining life of the awards is \$180,000 ($\$3 \times 60,000$ share options). The amount to be recognized in 20X7 is \$90,000 ($\$180,000 / 2$). The remaining \$90,000 of compensation expense would be recognized in 20X8 as long as the target is achieved.

Example 5.10: Modification of Performance Condition – Probable to Probable

On January 1, 20X6, ABC Corp. grants 10,000 share options with an exercise price of \$10 per share option (which equals the current share price) to each of its six regional sales managers. The share options vest if ABC's market share for its new product line equals or exceeds 10% at the end of three years. The grant-date fair value is \$3 per share option. ABC's accounting policy is to estimate the number of forfeitures and to include that estimate in its initial accrual of compensation cost. ABC does not expect any forfeitures.

Based on its forecasts, ABC estimates that the market share target is probable of achievement. As a result, compensation cost of \$60,000 was recognized in 20X6 and 20X7 ($\$3 \times 60,000 / 3$ years). On January 1, 20X8, ABC raises the market share target to 15% to motivate its regional sales managers. No other terms or conditions of the original award are changed. As of January 1, 20X8, the share options are out-of-the-money because of a general stock market decline. Consequently, the fair value of the awards at the date of the modification is \$2.40 per share option. Immediately prior to the modification, the original market share target continued to be probable of achievement. In addition, ABC estimates that the new market share target is also probable of achievement.

If the modified target (15%) is achieved, ABC would recognize compensation cost of \$60,000 in 20X8 (cumulative compensation cost of \$180,000 based on the grant-date fair value of the share options). That is, the grant-date fair value constitutes the *floor* on the compensation cost and continues to be the basis on which compensation cost is recognized rather than using the \$2.40 fair value amount as of the date of the modification. In the event that the original target (10%) is achieved, but the modified target was not, ABC *would still* recognize compensation cost of \$60,000 in 20X8

(cumulative compensation cost of \$180,000 based on the grant-date fair value of the share options), even though the share options would not vest. ABC would reverse previously recognized compensation cost only if the *original* target is not achieved. This type of modification is infrequent.

If the fair value of the awards on the modification date is \$4 per share option and the revised performance target is probable of being achieved, then incremental compensation cost would be recognized. So, in this case, cumulative compensation cost would be \$240,000 ($\$4 \times 60,000$). As of the date of the modification, compensation cost of \$120,000 has already been recognized. Therefore, ABC would recognize \$120,000 in 20X8 ($\$240,000 - \$120,000$).

While this example scenario is for employee awards, its guidance also applies to nonemployee awards, other than for the compensation cost attribution. Nonemployee award compensation cost is recognized over a vesting period, and it is recognized in the same manner as if the grantor had paid cash. See Paragraph 4.086a.

Example 5.10a: Modification of Performance Condition – Not Probable to Not Probable

On January 1, 20X5, ABC Corp. grants 100,000 share options to its CEO with an option value of \$10 per share. The share options have a four-year service condition and the terms of the awards stipulate that a change in control must occur during that four-year period for the awards to vest. A change in control is defined in the agreement as an acquisition of more than 50% of ABC's shares and/or when an IPO occurs. The grant-date fair value is \$3 per share option. ABC's accounting policy is to estimate the number of forfeitures and it includes that estimate in its initial accrual of compensation cost. ABC does not expect any forfeitures.

At the time the award is granted, ABC concludes that the occurrence of a change in control during the four-year service period is not probable and therefore, no compensation cost is recognized.

As of December 31, 20X7, a change in control has not occurred and on January 1, 20X8, ABC modifies the award by extending the service condition one additional year (thus extending the service condition to December 31, 20X9). The grant-date fair value on the modification date is \$5 per share option. ABC concludes that this is a Type IV modification as the performance condition was not probable of being met before and after the modification. As a result, ABC continues to recognize no compensation cost.

On January 1, 20X9, a change in control event occurs and the performance condition is met. As the original award was not probable of vesting, the modified grant-date fair value is used to determine the amount of compensation cost to be recognized for the award. The fair value of the modified award for the years of service completed since the modification of \$250,000 is recorded on the acquisition date as compensation cost [$(\$5 \times 100,000$ share options) \times (1 years of service provided / 2-year service period after the

modification)]. The remaining \$250,000 of compensation cost will be recorded over the remaining service period of one year.

5.016 In some situations, entities grant awards with performance conditions that include a series of performance hurdles (often based on the same performance metric) such that the number of awards that vests is dependent on how many of the performance hurdles are achieved. For example, an entity may grant an award that vests based on the achievement of growth in EPS during the service or vesting period and the grantee can earn from 0 to 100 units depending on the EPS results during the period. ASC Topic 718 requires the recognition of compensation cost based on the target performance level that is probable. (ASC paragraph 718-20-55-38) In these situations, if an entity modifies the performance targets in a manner that makes a higher performance target probable, the incremental tranche of awards that has become probable due to the modification is deemed to be a *not probable-to-probable* modification. The tranches that were probable both before and after the modification of the performance targets are not deemed to have been modified. Although it would be unlikely because grantors often are either unwilling or unable to modify awards in a manner making achievement more difficult, if such a modification were made, it could result in a vesting condition changing from probable to not probable of achievement. For this situation, the entity would continue to account for the award based on the original vesting conditions.

Example 5.11: Modification of Performance Target – Not Probable to Probable for Tranche

On January 1, 20X6, ABC Corp. grants nonvested stock units to each of its six regional sales managers. The number of nonvested stock units that vest are based on the cumulative growth in ABC's EPS during the next three years. If cumulative EPS growth exceeds 10%, 1,000 nonvested stock units will vest. If cumulative EPS growth exceeds 15%, 3,000 nonvested stock units will vest. If cumulative EPS growth exceeds 20%, 5,000 nonvested stock units will vest. The grant-date fair value of the nonvested stock unit is \$15 per unit. ABC's accounting policy is to estimate the number of forfeitures and to include that estimate in its initial accrual of compensation cost. ABC does not expect any forfeitures.

Based on its forecasts, in 20X6, ABC estimates that the cumulative EPS growth will be in excess of 20%. Therefore, in 20X6, ABC recognizes compensation cost of \$25,000 (5,000 nonvested stock units × \$15 per unit / 3-year service period). In 20X7, ABC estimates that its cumulative EPS growth will be greater than 15% but less than 20%. Therefore, in 20X7, ABC recognizes compensation cost of \$5,000 [3,000 nonvested stock units × \$15 per unit × (2 years of service provided / 3-year service period) - \$25,000 compensation cost recognized in 20X6].

In 20X8, ABC continues to estimate that the cumulative EPS growth will be greater than 15% but less than 20%. In 20X8, ABC modifies the performance target such that if cumulative EPS growth exceeds 17%, 5,000 nonvested share units will vest. At the date

of the modification, the fair value of the nonvested stock unit is \$13 per unit. The 3,000 nonvested stock units that were previously deemed to be probable of vesting have not been modified. Therefore, ABC will recognize compensation cost in 20X8 related to the original award of \$15,000 [3,000 nonvested stock units × \$15 per unit / 3-year service period].

The 2,000 nonvested stock units (5,000 expected to vest after the modification – 3,000 expected to vest before the modification) are treated as a *not probable-to-probable* modification. Therefore, ABC will recognize compensation cost equal to the fair value of the 2,000 nonvested stock units determined at the date of the modification (\$13 per unit). The additional compensation cost recognized in 20X8 related to the modification is \$26,000 (2,000 nonvested stock units × \$13 per unit). Therefore, the total compensation cost recognized in 20X8 is \$41,000 (\$15,000 for awards not modified + \$26,000 for awards modified).

While this example scenario is for employee awards, its guidance also applies to nonemployee awards, other than for the compensation cost attribution. Nonemployee award compensation cost is recognized over a vesting period, and it is recognized in the same manner as if the grantor had paid cash. See Paragraph 4.086a

The following illustrative example is an excerpt from the FASB Codification starting at paragraph 718-20-55-109, which illustrates a Case with a Type II Probable to Not Probable Modification (Case B).

Excerpt from ASC 718-20-55-109; 55-113 through 55-115

Compensation – Stock Compensation – Awards Classified as Equity

718-20-55-109. . . . Entity T grants 1,000 at-the-money employee share options with a contractual term of 10 years to each of 10 employees in the sales department. All share options vest at the end of three years (cliff vesting), which is an explicit service (and requisite service) period of three years. Vesting is conditional upon selling 150,000 units of product A (the original sales target) over the 3-year explicit service period. The grant-date fair value of each option is \$14.69. For simplicity, this Example assumes that no forfeitures will occur from employee termination; forfeitures will only occur if the sales target is not achieved.

Case B: Type II Probable to Improbable Modification

718-20-55-113. It is generally believed that Type II modifications will be rare; therefore, this illustration has been provided for the sake of completeness. Based on historical sales patterns and expectations related to the future, management of Entity T believes that at the grant date, it is probable that the sales target (150,000 units of product A) will be achieved. At January 1, 20X7, 102,000 units of product A have been sold and the options are out-of-the-money because of a general stock market decline. Entity T's management

implements a cash bonus program based on achieving an annual sales target for 20X7. The options are neither cancelled nor settled as a result of the cash bonus program. The cash bonus program would be accounted for using the same accounting as for other cash bonus arrangements. Concurrently, the sales target for the option awards is revised to 170,000 units of Product A. No other terms or conditions of the original award are modified. Management believes that the modified sales target is not probable of achievement; however, they continue to believe that the original sales target is probable of achievement. Immediately before the modification, total compensation cost expected to be recognized over the 3-year vesting period is \$146,900 or \$14.69 multiplied by the number of share options expected to vest (10,000). Because no other terms or conditions of the award were modified, the modification does not affect the per-share-option fair value (assumed in this Case to be \$8 at the modification date). Moreover, because the modification does not affect the number of share options expected to vest under the original vesting provisions, Entity T would determine incremental compensation cost in the following manner.

| | | |
|--|----|-----------------|
| Fair value of modified share option | \$ | 8 |
| Share options expected to vest under original sales target | | <u>10,000</u> |
| Fair value of modified award | \$ | <u>80,000</u> |
| Fair value of original share option | \$ | 8 |
| Share options expected to vest under original sales target | | <u>10,000</u> |
| Fair value of original award | \$ | <u>80,000</u> |
| Incremental compensation cost of modification | \$ | <u><u>0</u></u> |

718-20-55-114. In determining the fair value of the modified award for this type of modification, an entity shall use the greater of the options expected to vest under the modified vesting condition or the options that previously had been expected to vest under the original vesting condition.

718-20-55-115. This paragraph illustrates the cumulative compensation cost Entity T should recognize for the modified award based on three potential outcomes:

- (a) Outcome 1 -- achievement of the modified sales target. In Outcome 1, all 10,000 share options vest because the salespeople sold at least 170,000 units of Product A. In that outcome, Entity T would recognize cumulative compensation cost of \$146,900.
- (b) Outcome 2 -- achievement of the original sales target. In Outcome 2, no share options vest because the salespeople sold more than 150,000 units of Product A but less than 170,000 units (the modified sales target is not achieved). In that outcome, Entity T would recognize cumulative compensation cost of \$146,900 because the share options would have vested under the original terms and conditions of the award.
- (c) Outcome 3 -- failure to achieve either sales target. In Outcome 3, no share options vest because the modified sales target is not achieved; additionally, no share options would have vested under the original terms and conditions of the

award. In that case, Entity T would recognize cumulative compensation cost of \$0.

While this example is for employee awards, paragraphs 718-20-55-109A and 55-109B provide guidance that, if this example were for nonemployee awards, the cumulative amount of compensation cost that an entity would recognize because of a modification would be the same for the employee awards that are modified. However, nonemployee awards may have a different cost attribution, in that they are recognized in the same manner as if the grantor had paid cash for the goods or services instead of paying with or using the share-based payment awards.

The following illustrative example is an excerpt from the FASB Codification, which illustrates a Case with a Type III Not Probable to Probable Modification (Case C).

Excerpt from ASC 718-20-55-109; 55-116; 55-117

Compensation – Stock Compensation – Awards Classified as Equity

718-20-55-109. . . . Entity T grants 1,000 at-the-money employee share options with a contractual term of 10 years to each of 10 employees in the sales department. All share options vest at the end of three years (cliff vesting), which is an explicit service (and requisite service) period of three years. Vesting is conditional upon selling 150,000 units of product A (the original sales target) over the 3-year explicit service period. The grant-date fair value of each option is \$14.69. For simplicity, this Example assumes that no forfeitures will occur from employee termination; forfeitures will only occur if the sales target is not achieved.

Case C: Type III Improbable to Probable Modification

The following Example is an excerpt from ASC paragraphs 718-20-55-109 through 119.

718-20-55-116. Based on historical sales patterns and expectations related to the future, management of Entity T believes that at the grant date it is not probable that the sales target will be achieved. On January 1, 20X7, 80,000 units of Product A have been sold. To further motivate the salespeople, the sales target is lowered to 130,000 units of Product A (the modified sales target). No other terms or conditions of the original award are modified. Entity T lost a major customer for Product A in December 20X6; hence, management continues to believe that the modified sales target is not probable of achievement. Immediately before the modification, total compensation cost expected to be recognized over the 3-year vesting period is \$0 or \$14.69 multiplied by the number of share options expected to vest (zero). Because no other terms or conditions of the award were modified, the modification does not affect the per-share-option fair value (assumed in this Case to be \$8 at the modification date). Since the modification affects the number of share options expected to vest under the original vesting provisions, Entity T will determine incremental compensation cost in the following manner.

| | |
|--|-------------------------|
| Fair value of modified share option | \$ 8 |
| Share options expected to vest under original sales target | 10,000 |
| Fair value of modified award | <u>\$ 80,000</u> |
| Fair value of original share option | \$ 8 |
| Share options expected to vest under original sales target | - |
| Fair value of original award | <u>\$ -</u> |
| Incremental compensation cost of modification | <u><u>\$ 80,000</u></u> |

718-20-55-117. This paragraph illustrates the cumulative compensation cost Entity T should recognize for the modified award based on three potential outcomes:

- (a) Outcome 1 — achievement of the modified sales target. In Outcome 1, all 10,000 share options vest because the salespeople sold at least 130,000 units of Product A. In that outcome, Entity T would recognize cumulative compensation cost of \$80,000 (10,000 × \$8).
- (b) Outcome 2 — achievement of the original sales target and the modified sales target. In Outcome 2, Entity T would recognize cumulative compensation cost of \$80,000 because in a Type IV modification the original vesting condition is generally not relevant (that is, the modified award generally vests at a lower threshold of service or performance).
- (c) Outcome 3 — failure to achieve either sales target. In Outcome 3, no share options vest because the modified sales target is not achieved; in that case, Entity T would recognize cumulative compensation cost of \$0.

While this example is for employee awards, paragraphs 718-20-55-109A and 55-109B provide guidance that, if this example were for nonemployee awards, the cumulative amount of compensation cost that an entity would recognize because of a modification would be the same for the employee awards that are modified. However, nonemployee awards may have a different cost attribution, in that they are recognized in the same manner as if the grantor had paid cash for the goods or services instead of paying with or using the share-based payment awards.

MODIFICATION OF A PERFORMANCE TARGET IN RESPONSE TO A NEW ACCOUNTING STANDARD OR OTHER SPECIFIED EVENT

5.017 The terms of a performance condition may no longer suit the original compensation objective if there is an event that was not contemplated at the time the award was granted. This may include the adoption of a new accounting standard, or another specified event, such as an acquisition or disposition of a business, that changes its operating results compared with what was expected when the performance condition was initially determined. The change could be made pursuant to a new accounting standard as well as a voluntary accounting change. Some companies have concluded that the plan documents

support an interpretation that allows for continuing to compute operating results using the old accounting principle or based on the operations prior to the event for purposes of evaluating whether the performance condition was met. However, this may not be practicable if the changes in accounting principle or from the event are pervasive, or the remaining performance measurement period is long. In addition, it may be counterproductive to continue to have management focus on achieving incentives under an old accounting principle or operations that are not truly reflective of the ongoing entity, rather than manage the current business with its current set of accounting principles or current operations.

5.018 Another common approach to preserve an award's original compensation objective is to modify its performance condition with an aim to retain the original difficulty of achieving the performance condition. Some plan documents specify that in the event of an accounting change, the adoption of a new accounting standard, or other specified event, a modification must be made to preserve the value or the same degree of difficulty in achieving the performance condition under the new accounting principle or other specified event. Because some plan documents do not clearly state whether performance conditions are required to be revised for the adoption of new accounting standards or occurrence of an other specified event, a company may need to seek legal advice to determine if the award requires the company to make a preservation modification. The accounting and related assessments of the consequences from changes in accounting policy or other specified event leading to a modification of a performance condition can vary based on facts and circumstances and require significant judgment. The scenarios below summarize the points to consider when a modification is made to preserve the value of share-based payment awards on adoption of a new accounting standard, a voluntary accounting change, or other specified event.

Scenario 1 – Plan documents or awards contain a provision

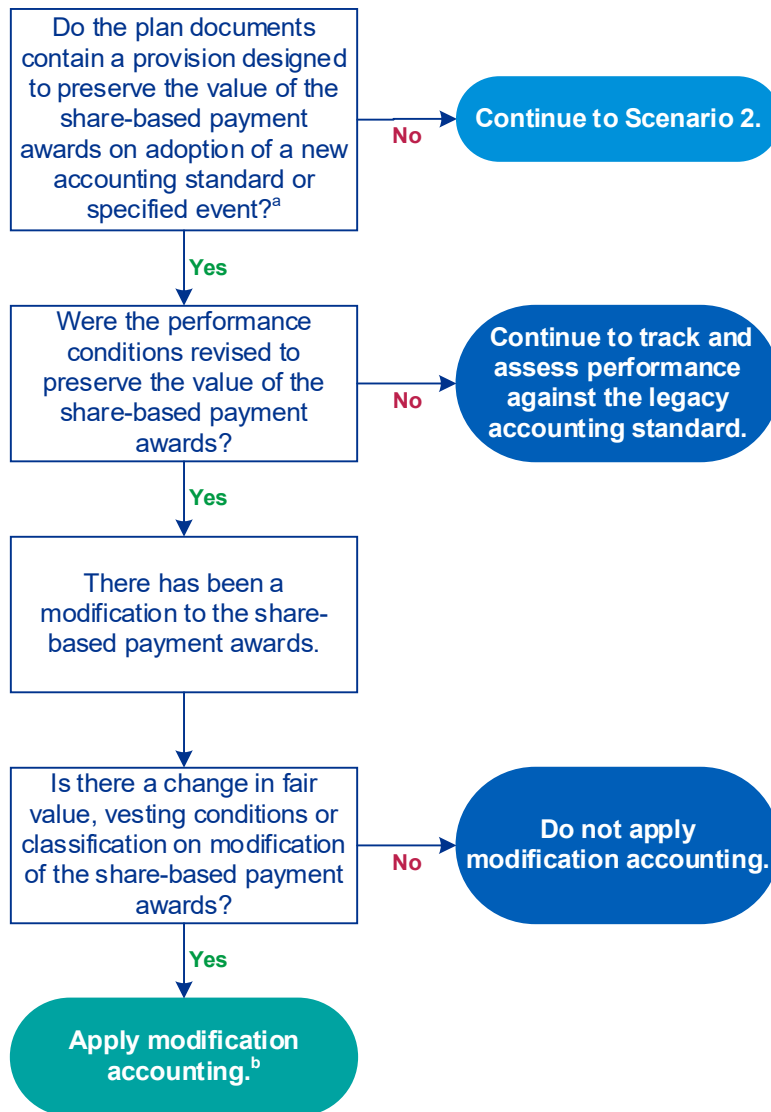

a. This scenario also applies to a voluntary accounting change.

b. If the plan documents contain a provision that requires a revision to preserve the value of the awards on adoption of a new accounting standard, voluntary accounting change, or specified event, we would expect the modification to result in minimal or no incremental compensation cost, if properly structured. For additional guidance on modification accounting, see paragraphs 5.007 – 5.016.

Scenario 2 – Plan documents or awards do not contain a provision

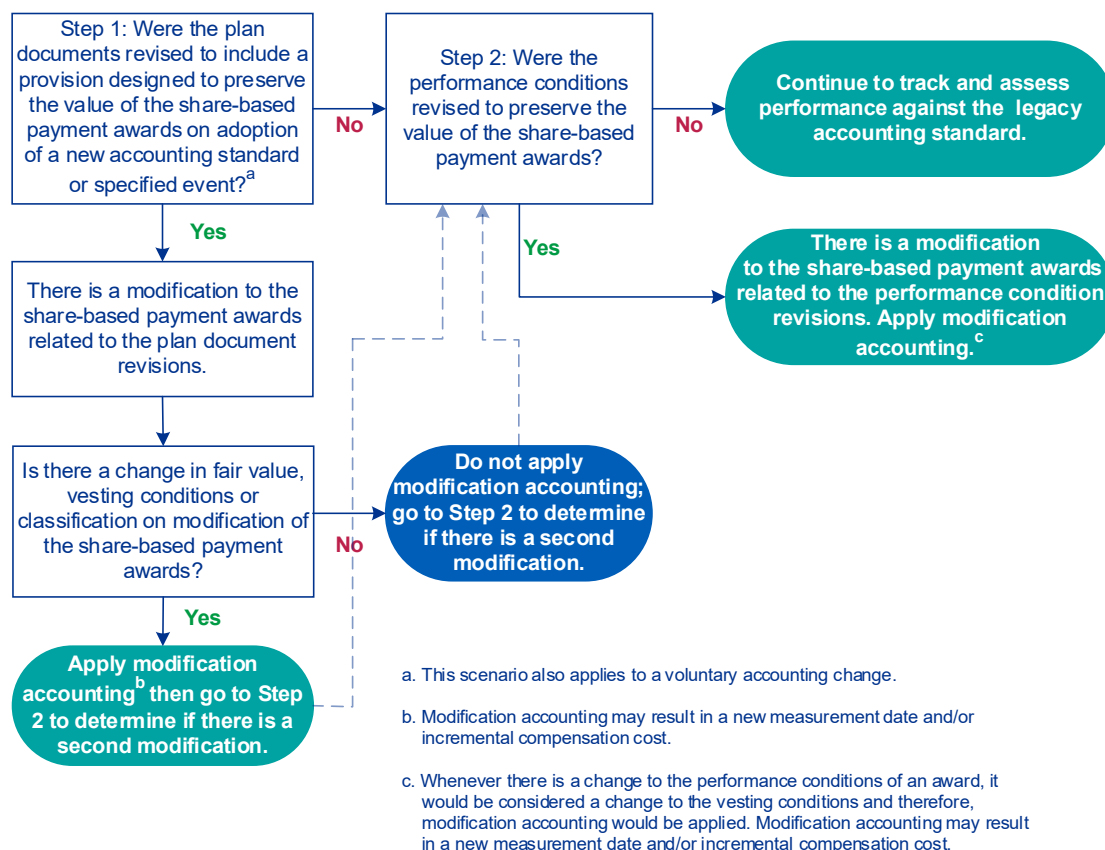

5.019 Similar to awards modified to add an anti-dilution provision as discussed in Paragraphs 5.042 and 5.043, an assessment should be performed in Scenario 2 to determine whether the awards were modified to add the preservation provision in contemplation of adopting a new accounting standard or a voluntary accounting change. If the modification is not made in contemplation of such events, a comparison of the fair value of the modified awards and the fair value of the original awards immediately before the modification is not required, as the modification does not affect the inputs to the technique used to value the awards so there would not be a new performance metric to consider. As a result, we would expect no incremental compensation to result at the time the provision is added. Conversely, if the modification is made in contemplation of such events, there would be a comparison of the fair value of the awards pre- and post-modification on the date of the modification, taking into account the effect of the change in accounting standard on the value of the award in the same way as a modification would be evaluated if no such provision is in the plan. The fair value of the pre-modified award does not include adjustments to the award for the adoption of the accounting standard. Therefore, the fair value of the pre-modified award is determined using the value that would have resulted had the adoption of the accounting standard (and its related effects)

occurred but the award had not been modified. This will likely result in incremental compensation cost.

MODIFICATIONS THAT AFFECT AWARDS WITH MARKET CONDITIONS

5.020 The accounting for the modification of an award with a market condition differs from the accounting for a modification of an award with a performance or service condition. We believe entities should distinguish between situations in which the market condition in an award is modified and situations in which an award contains a market condition but some other aspect of the award is the subject of the modification. When a market condition in an award is modified, the probability of satisfying the original market condition does not affect the recognition of compensation cost because the market condition was incorporated into the grant-date fair value measurement. Accordingly, the total compensation cost recognized for the modification of a market condition is subject to the same *floor* considerations as an award with a service condition that is expected to be satisfied at the date of the modification. Therefore, the compensation cost will not be reduced below the grant-date fair value of the original award. In addition, the effect of the modification on the number of awards expected to become exercisable is considered when measuring the incremental compensation cost from the modification. However, if the award also had a performance condition and that original performance condition was not probable of vesting, the entire modification would be considered an improbable-to-improbable or improbable-to-probable modification and the grant date fair value would be irrelevant (see Example 5.8).

Example 5.12: Modification of a Market Condition in an Award

On January 1, 20X6, ABC Corp. granted 1,000 share options. The share options have an exercise price of \$10 (the market price of the shares on the grant date) and become exercisable when ABC's share price reaches \$18 (a market condition). ABC used a simulation to determine that the grant-date fair value of the share options is \$3.50 and the derived service period is four years. ABC's accounting policy is to estimate the number of forfeitures and to include that estimate in its initial accrual of compensation cost. ABC estimated that 80% (or 800) of the employees receiving awards would remain employed for the entire derived service period.

In 20X6, ABC recognized \$700 of compensation cost [$\$3.50 \times (1,000 \times 80\%) / 4$ years].

On January 1, 20X7, when its stock price had dropped to \$8, ABC modified the market condition so that the share options become exercisable when the share price reaches \$12. To determine if the modification resulted in incremental compensation cost, ABC measured the fair value of the original award immediately before the modification (\$1.75), and compared that to the fair value of the modified award (\$2.50). The requisite service period of the modified award, derived from the simulation used to value the award, is two years. Due to the reduction in the requisite service period, ABC estimated that 90% (or 900) of the employees receiving awards would remain employed for the

entire derived service period. The additional 100 share options expected to vest as a result of the modification are included in calculating incremental compensation cost.

Incremental compensation cost resulting from the modification is calculated as follows:

| | |
|--|----------------|
| Fair value of modified share options | \$2.50 |
| Share options expected to vest (modified conditions) | × 900 |
| Fair value of modified award | <u>\$2,250</u> |
| Fair value of original share options | \$1.75 |
| Share options expected to vest (original conditions) | × 800 |
| Fair value of original award | <u>\$1,400</u> |
| Incremental compensation cost | \$850 |

ABC will recognize compensation cost of \$2,950 [(\$2,800 - \$700) + \$850] over the remaining two-year requisite service period. At the end of the derived service period, the total compensation recognized will be \$3,650 (\$700 + \$2,950).

While this example scenario is for employee awards, its guidance also applies to nonemployee awards, other than for the compensation cost attribution. Nonemployee award compensation cost is recognized over a vesting period, and it is recognized in the same manner as if the grantor had paid cash. See Paragraph 4.086a.

MODIFICATIONS REGARDING AN AWARD'S CLASSIFICATION

5.021 A modification may affect the classification of an award. For example, an award may originally have been share-settled and, therefore, equity-classified and the award is modified to allow it to be net-cash settled at the grantee's option. This would cause the award to become liability-classified. Conversely, a modification could cause the award to change from liability-classified to equity-classified. ASC paragraph 718-20-55-122

5.022 ASC paragraphs 718-20-35-3, 35-4, and 718-30-35-5 establish the principle that for an equity-classified award that is modified, the cumulative compensation cost cannot be less than the grant-date fair value of the award unless, at the date of modification, it was not probable that the original award would vest under its terms (not probable-to-probable modification). Consistent with that principle, the modification of an award that changes its classification from equity to liability will result in cumulative compensation cost equal to the greater of (1) the grant-date fair value of the original equity-classified award or (2) the fair value of the modified liability-classified award when it is settled (unless at the date of the modification, the original award was not probable of vesting under its original terms). See Paragraph 5.026a on distinguishing between a settlement and modification that changes the classification from equity to a liability. ASC paragraphs 718-20-35-3 and 35-4, 55-126 and 55-127, and 718-30-35-5

Example 5.13: Modification of an Award That Changes Its Classification from Equity to Liability - Part I

ABC Corp. grants 10,000 share options to its employees on January 1, 20X6. The awards can only be physically settled (i.e., upon exercise, the employees pay ABC an amount equal to the exercise price and will receive shares of ABC stock). As a result, the award is equity-classified. At the grant date, the share options had a fair value of \$4 and cliff vested after four years of service.

On January 1, 20X8, ABC modifies the award such that employees are permitted to net-cash settle the award. No other terms of the award are changed by the modification. As a result of the modification, the award becomes liability-classified. All of the awards are settled on December 31, 20Y0.

The fair value of the award at the date of the modification and at the end of each year until settlement is as follows (none of the awards are forfeited):

| | |
|----------|--------|
| 1/1/X8 | \$4.50 |
| 12/31/X8 | \$4.20 |
| 12/31/X9 | \$3.80 |
| 12/31/Y0 | \$4.70 |

Compensation cost recognized in 20X6 and 20X7

| | |
|--|----------|
| Grant-date fair value of awards (10,000 × \$4) | \$40,000 |
| Requisite service period | 4 years |
| Compensation cost recognized per year | \$10,000 |

At December 31, 20X7, ABC has \$20,000 recorded in additional paid-in capital (APIC) – an amount equal to the cumulative compensation cost to date.

On January 1, 20X8, ABC would record the following:

| | Debit | Credit |
|-------------------------------|--------|--------|
| APIC | 20,000 | |
| Compensation cost | 2,500 | |
| Share-based payment liability | | 22,500 |

The liability equals the fair value of the award times the proportion of the requisite service that has been provided: $(10,000 \times \$4.50) \times (2 \text{ years} / 4 \text{ years})$.

Compensation cost is recognized for the increase in the fair value of the award.

On December 31, 20X8, ABC would record the following:

| | | |
|--|-------|---------------|
| Compensation cost | 9,000 | |
| Share-based payment liability | | 9,000 |
| Liability at 12/31/X8: $(10,000 \times \$4.20) \times 3 / 4$ | | 31,500 |
| Liability at 1/1/X8: $(10,000 \times \$4.50) \times 2 / 4$ | | <u>22,500</u> |
| Increase in liability | | 9,000 |

On December 31, 20X9, ABC would record the following:

| | | |
|--|-------|---------------|
| Compensation cost | 8,500 | |
| Share-based payment liability | | 6,500 |
| APIC | | 2,000 |
| Liability at 12/31/X9: $(10,000 \times \$3.80) \times 4 / 4$ | | 38,000 |
| Liability at 12/31/X8: $(10,000 \times \$4.20) \times 3 / 4$ | | <u>31,500</u> |
| Increase in liability | | 6,500 |

Cumulative compensation cost cannot be less than the grant-date fair value of the original award ($10,000 \times \$4 = \$40,000$). Compensation cost recognized in previous years is \$31,500. Therefore, an additional \$2,000 of compensation cost is recognized in 20X9 (for a total of \$8,500) and the offset is recorded as a credit to additional paid-in capital.

For 20Y0, ABC would record the following:

| | | |
|--|-------|---------------|
| Compensation cost | 7,000 | |
| APIC | 2,000 | |
| Share-based payment liability | | 9,000 |
| Liability at 12/31/Y0: $(10,000 \times \$4.70) \times 4 / 4$ | | 47,000 |
| Liability at 12/31/X9: $(10,000 \times \$3.80) \times 4 / 4$ | | <u>38,000</u> |
| Increase in liability | | 9,000 |

At settlement, ABC would record the following:

| | | |
|-------------------------------|--------|--------|
| Share-based payment liability | 47,000 | |
| Cash | | 47,000 |

Cumulative compensation cost recognized is the greater of (1) grant-date fair value of the original award (\$40,000), or (2) fair value of the liability at the date of settlement (\$47,000). In previous periods, cumulative compensation recognized was \$40,000, resulting in an additional \$7,000 ($\$47,000 - \$40,000$) of compensation cost to recognize for 20Y0.

While this example scenario is for employee awards, its guidance also applies to nonemployee awards, other than for the compensation cost attribution. Nonemployee

award compensation cost is recognized over a vesting period, and it is recognized in the same manner as if the grantor had paid cash. See Paragraph 4.086a.

Example 5.14: Modification of an Award That Changes Its Classification from Equity to Liability - Part II

Assume the same information as in Example 5.13, except as described below.

The fair value of the award at the date of the modification and at the end of each year until settlement is as follows (none of the awards are forfeited):

| | |
|----------|--------|
| 1/1/X8 | \$3.90 |
| 12/31/X8 | \$2.50 |
| 12/31/X9 | \$4.10 |
| 12/31/Y0 | \$3.70 |

Compensation cost recognized in 20X6 and 20X7

| | |
|--|----------|
| Grant-date fair value of awards (10,000 × \$4) | \$40,000 |
| Requisite service period | 4 years |
| Compensation cost recognized per year | \$10,000 |

At December 31, 20X7, ABC has \$20,000 recorded in APIC – an amount equal to the cumulative compensation cost to date.

On January 1, 20X8, ABC would record the following:

| | Debit | Credit |
|-------------------------------|--------|--------|
| APIC | 19,500 | |
| Share-based payment liability | | 19,500 |

The liability equals the fair value of the award times the proportion of the requisite service that has been provided: $(10,000 \times \$3.90) \times (2 / 4)$.

Because the fair value of the award at the date of the modification is less than its grant-date fair value, no compensation cost is recognized at the date of the modification.

On December 31, 20X8, ABC would record the following:

| | | |
|--|--------|------------|
| Share-based payment liability | 750 | |
| Compensation cost | 10,000 | |
| APIC | | 10,750 |
| Liability at 12/31/X8: $(10,000 \times \$2.50) \times 3 / 4$ | | 18,750 |
| Liability at 1/1/X8: $(10,000 \times \$3.90) \times 2 / 4$ | | 19,500 |
| Decrease in liability | | <u>750</u> |

Cumulative compensation cost cannot be less than the amount based on grant-date fair value ($10,000 \times \$4 \times 3 / 4 = \$30,000$). Compensation cost previously recognized was \$20,000 (\$10,000 in 20X8 and 20X9), resulting in additional compensation cost of \$10,000 ($\$30,000 - \$20,000$) to recognize for 20X8.

On December 31, 20X9, ABC would record the following:

| | | |
|--|--------|---------------|
| Compensation cost | 11,000 | |
| APIC | 11,250 | |
| Share-based payment liability | | 22,250 |
| Liability at 12/31/X9: $(10,000 \times \$4.10) \times 4 / 4$ | | 41,000 |
| Liability at 12/31/X8: $(10,000 \times \$2.50) \times 3 / 4$ | | <u>18,750</u> |
| Increase in liability | | 22,250 |

Cumulative compensation cost is the greater of the grant-date fair value of the original award (\$40,000) or the fair value of the liability (\$41,000). Compensation cost previously recognized is \$30,000, resulting in additional compensation cost of \$11,000 ($\$41,000 - \$30,000$) to recognize for 20X9.

For 20Y0, ABC would record the following:

| | | |
|--|-------|---------------|
| Share-based payment liability | 4,000 | |
| Compensation cost | | 1,000 |
| APIC | | 3,000 |
| Liability at 12/31/Y0: $(10,000 \times \$3.70) \times 4 / 4$ | | 37,000 |
| Liability at 12/31/X9: $(10,000 \times \$4.10) \times 4 / 4$ | | <u>41,000</u> |
| Decrease in liability | | 4,000 |

At settlement, ABC would record the following:

| | | |
|-------------------------------|--------|--------|
| Share-based payment liability | 37,000 | |
| Cash | | 37,000 |

Cumulative compensation cost recognized is the greater of (1) grant-date fair value of the original award (\$40,000), or (2) fair value of the liability at the date of settlement (\$37,000). In previous periods, cumulative compensation recognized was \$41,000, resulting in a reduction of compensation cost of \$1,000 ($\$41,000 - \$40,000$) to recognize for 20Y0.

While this example scenario is for employee awards, its guidance also applies to nonemployee awards, other than for the compensation cost attribution. Nonemployee award compensation cost is recognized over a vesting period, and it is recognized in the same manner as if the grantor had paid cash. See Paragraph 4.086a.

5.023 When a liability-classified award is modified so that it becomes equity-classified without changing any of the other terms of the award, the fair value of the award at the date of the modification becomes its measurement basis from that point forward, because an equity-classified award is not subsequently remeasured. Because an award that is liability-classified is adjusted for changes in its fair value each reporting period, a modification of an award that only changes its classification from liability to equity can result in cumulative compensation cost that is less than the award's grant-date fair value. This would occur if, at the date of the modification, the fair value of the liability-classified award is less than its grant-date fair value. ASC paragraphs 718-20-55-135 through 55-138

5.023a When a liability-classified award becomes equity-classified, and the award also is modified so that other terms of the award are changed, the fair value of the award would be calculated immediately before the modification, as a last mark-to-market, before its reclassification to equity. Once remeasured, modification accounting would be applied to the award. If the value of the modified award is less than the value of the unmodified award, the cumulative compensation cost would reflect the value of the unmodified award. Therefore, there would be no reversal of compensation cost recognized prior to the modification accounting, resulting in a floor set by the last remeasurement of the liability-classified award.

Example 5.15: Modification of an Award That Changes Its Classification from Liability to Equity – Part I

ABC Corp. grants 10,000 cash-settled share appreciation rights (SARs) to its employees on January 1, 20X6. Because the award is cash-settled, it is liability-classified. The award cliff vests after three years of service.

On January 1, 20X8, ABC modifies the award such that it is net-share settled. No other terms of the award are changed by the modification. As a result of the modification, the award becomes equity-classified. None of the awards are forfeited.

The fair value of the award is as follows:

| | |
|----------------------------|--------|
| 1/1/X6 (grant date) | \$4.00 |
| 12/31/X6 | \$4.20 |
| 12/31/X7 | \$4.80 |
| 1/1/X8 (modification date) | \$4.80 |

Compensation cost recognized in 20X6

| | |
|---|----------|
| Fair value of award, 12/31/X6 (10,000 × \$4.20) | \$42,000 |
| Requisite service period | 3 years |
| Compensation cost | \$14,000 |

Compensation cost recognized in 20X7

| | |
|---|-----------------|
| Fair value of award, 12/31/X7 (10,000 × \$4.80) | \$48,000 |
| Requisite service period | 2 / 3 years |
| Cumulative compensation cost | \$32,000 |
| Compensation cost previously recognized | 14,000 |
| Compensation cost recognized in 20X7 | <u>\$18,000</u> |

At the date of the modification (1/1/X8), the liability is \$32,000 and ABC would record the following entry:

| | Debit | Credit |
|-------------------------------|--------|--------|
| Share-based payment liability | 32,000 | |
| APIC | | 32,000 |

Compensation cost recognized in 20X8

| | |
|--|-----------------|
| Fair value of award modification (10,000 × \$4.80) = | \$48,000 |
| Requisite service period | <u>3 years</u> |
| Compensation cost recognized in 20X8 | <u>\$16,000</u> |

While this example scenario is for employee awards, its guidance also applies to nonemployee awards, other than for the compensation cost attribution. Nonemployee award compensation cost is recognized over a vesting period, and it is recognized in the same manner as if the grantor had paid cash. See Paragraph 4.086a.

Example 5.16: Modification of an Award That Changes Its Classification from Liability to Equity – Part II

Assume the same information as in Example 5.15, except that the fair value of the award is as follows:

| | |
|----------------------------|--------|
| 1/1/X6 (grant date) | \$4.00 |
| 12/31/X6 | \$4.20 |
| 12/31/X7 | \$3.90 |
| 1/1/X8 (modification date) | \$3.90 |

Compensation cost recognized in 20X6

| | |
|---|-----------------|
| Fair value of award, 12/31/X6 (10,000 × \$4.20) | \$42,000 |
| Requisite service period | <u>3 years</u> |
| Compensation cost | <u>\$14,000</u> |

Compensation cost recognized in 20X7

| | |
|---|--------------------|
| Fair value of award, 12/31/X7 (10,000 × \$3.90) | \$39,000 |
| Requisite service period | <u>2 / 3 years</u> |
| Cumulative compensation cost | <u>\$26,000</u> |

| | |
|---|-----------------|
| Compensation cost previously recognized | 14,000 |
| Compensation cost recognized in 20X7 | <u>\$12,000</u> |

At the date of the modification (1/1/X8), the liability is \$26,000 and ABC would record the following entry:

| | Debit | Credit |
|-------------------------------|--------|--------|
| Share-based payment liability | 26,000 | |
| APIC | | 26,000 |

Note: This amount is less than the grant-date fair value of the award.

Compensation cost recognized in 20X8

| | |
|--|----------------|
| Fair value of award modification (10,000 × \$3.90) | \$39,000 |
| Requisite service period | <u>3 years</u> |
| Compensation cost recognized in 20X8 | \$13,000 |

As noted in Example 5.15, while this example scenario is for employee awards, its guidance also applies to nonemployee awards, other than for the compensation cost attribution. Nonemployee award compensation cost is recognized over a vesting period, and it is recognized in the same manner as if the grantor had paid cash. See Paragraph 4.086a.

Application of ASC Paragraph 480-10-S99-3 When a Modification of an Award with a Contingent Cash Redemption Feature Occurs

5.024 When an award is modified, if the modified award has a contingent cash redemption feature that is beyond the entity's control but the occurrence of the event is not probable, the amount classified outside of permanent equity would be the redemption amount (usually the intrinsic value) at the date of the modification. The modification to the terms or conditions of a share-based payment award is treated as the exchange or repurchase of the original award for a new award, effectively resulting in a new grant date.

5.025 Consistent with related guidance in ASC Topic 480, *Distinguishing Liabilities from Equity*, and ASC paragraph 480-10-S99-3, a share-based payment award with a contingent cash-settlement feature that requires redemption of the share-based payment award only in the event that *all* equity holders' interests are redeemed should not result in the share-based payment award being classified as a liability on the event becoming probable of occurring nor in an amount being classified outside of permanent equity. See 3.069. An event that involves the redemption of *all* equity holders would include the sale of a company in an all-cash transaction or a liquidation of the company.

5.025a As noted in Paragraph 3.101, for equity-classified share-based payment instruments in which the contingent cash settlement feature is beyond the control of the company, the amount that initially should be classified outside of permanent equity is based on the grant-date redemption value of the award and the proportion of goods and

services provided to date. For most awards, the written terms of the plan provide for the redemption at the intrinsic value of the award at the redemption date. In these situations, such share-option awards initially granted *at-the-money* would have no initial redemption amount. When awards are modified, the intrinsic value often is no longer \$0. This necessitates an entry to record an amount outside permanent equity if the award has redemption features.

Example 5.17: Modification of an Award Containing a Contingent Redemption Feature

On January 1, 20X4, ABC Corp. grants 10,000 share options with an exercise price of \$10 and a four-year vesting period. The share options are contingently redeemable at the intrinsic value upon a change in control. At the date of the grant, the market price of the stock also was \$10. ABC's policy is to recognize forfeitures as they occur. On the grant date, the grant date intrinsic value is \$0 (market price is equal to the exercise price of \$10). As a result, as all equity holders' interests are redeemed in the event of the contingent cash-settlement feature (the change in control provision), on grant date, the award would be equity classified. In addition, on grant date, as the grant-date intrinsic redemption value of the award is \$0, there would not be an amount classified outside of permanent equity.

On December 28, 20X5, ABC accelerated the vesting of the share options so that they were immediately vested. At December 28, 20X5, the market price of the stock was \$25. The modification, which is the acceleration of the vesting, causes a new grant-date intrinsic-value measurement. Given the market price of the stock is \$25 on the modification date, the redemption amount is no longer \$0, and ABC would record an entry to present the redemption amount outside permanent equity.

Under ASC Topic 718, the amount to be presented outside of permanent equity would be \$150,000 ($[\$25 - \$10] \times 10,000$) because the share options are contingently redeemable at intrinsic value and the acceleration of the vesting causes a new *grant-date intrinsic-value* measurement for *all* of the share options.

However, the amount presented outside of equity would not be adjusted in subsequent periods unless it becomes probable that a change in control will occur, at which time the award would become liability-classified and measured at fair value.

Amounts classified outside of permanent equity do not affect earnings available to common shareholders in the EPS calculations because the shares involved are common shares and the redemption amount is not greater than fair value. See KPMG Handbook, *Earnings Per Share*, for further guidance on the effect of share-based payment awards on EPS.

SETTLEMENT OF AWARDS

5.026 Entities will sometimes repurchase equity-classified awards issued to grantees for cash or other assets (or liabilities incurred). If the amount paid to settle the award does not exceed the fair value of the award at the date of the repurchase, any difference between the amount paid and the recorded amount of the award should be charged to equity.

Conversely, if the entity pays an amount in excess of the fair value of the award at the date it is repurchased, the incremental amount paid in excess of the award's fair value on the date of settlement should be recognized as additional compensation cost. The repurchase of an unvested award (where the promised goods or services have not been delivered or the requisite service has not been rendered) is, in effect, a modification to immediately vest the award. Any compensation cost measured at the grant date, but not yet recognized should be recognized at the date of repurchase in accordance with its policy election as described in Paragraph 5.009. ASC paragraph 718-20-35-7

5.026a It is important to distinguish between a settlement (including a short-term offer to settle an award discussed in Paragraphs 5.028 through 5.029) and a modification that changes the classification from equity to liability. A modification that changes classification from equity to liability may result in incremental compensation cost even if the modified award has the same fair value as the original award at the modification date. This is because the entity must recognize the fair value of the liability, and any excess of the amount above the original award's grant-date fair value would result in compensation expense (see Paragraph 5.022). In contrast, in a settlement only the excess of the repurchase price above fair value results in incremental compensation cost (see Paragraph 5.026). When either of the following are present, we believe the arrangement represents a modification rather than a short term offer to settle an award:

- the grantee is required to continue providing services to the entity for a period of time after the offer is accepted to be entitled to the payment; or
- the payment continues to be indexed to the entity's shares.

Example 5.18: Settlement of Vested Share Options

On January 1, 20X6, ABC Corp. grants 25,000 share options with an exercise price of \$12 per share option (the current share price). The equity-classified awards cliff vest after three years of service. The grant-date fair value is \$5 per share option. ABC recognizes compensation cost of \$125,000 ($25,000 \times \5) over the three-year requisite service period because no awards are forfeited. ABC's accounting policy is to recognize forfeitures as they occur.

On March 31, 20X9, after the share options have vested, ABC offers to settle the outstanding share options for cash. Due to a decrease in ABC's stock price to \$8 per share, the current fair value of the award is \$2 per share option. Assume all 25,000 share options are still outstanding.

Scenario 1

ABC pays \$2 per outstanding share option and recognizes the settlement as a repurchase of an outstanding equity instrument. No additional compensation cost is recognized because the amount paid does not exceed the current fair value of the award. Previously recognized compensation cost is not adjusted. The journal entry to record the repurchase is:

| | Debit | Credit |
|------|--------------|---------------|
| APIC | 50,000 | |
| Cash | | 50,000 |

Scenario 2

ABC offers to settle the outstanding share options at current fair value (\$2 per share option) through the issuance of fully vested shares. ABC issues 6,250 shares of stock (\$50,000 / \$8 per share). No additional compensation cost is recognized because the fair value of the shares issued equals the current fair value of the share options. The only journal entry necessary is recording the par value of the shares issued by reclassifying that amount from additional paid-in capital to common stock.

Scenario 3

ABC pays \$3 per outstanding share option and records additional compensation cost for the amount of the purchase price in excess of the current fair value of the award. The journal entry to record the repurchase is:

| | | |
|-------------------|--------|--------|
| Compensation cost | 25,000 | |
| APIC | 50,000 | |
| Cash | | 75,000 |

While this example scenario is for employee awards, its guidance also applies to nonemployee awards, other than for the compensation cost attribution. Nonemployee award compensation cost is recognized over a vesting period, and it is recognized in the same manner as if the grantor had paid cash. See Paragraph 4.086a.

Example 5.19: Settlement of Unvested Shares – Alternative I

On January 1, 20X6, ABC Corp. grants 100,000 nonvested shares that cliff vest after four years of service. ABC's stock is \$5 per share on the date of grant. ABC's accounting policy is to estimate the number of forfeitures and to include that estimate in its initial accrual of compensation cost. ABC estimates that 20,000 nonvested shares will be forfeited prior to the completion of the four-year requisite service period.

On January 1, 20X8, ABC offers to settle the nonvested shares for cash of \$8 when its stock price is \$8 per share. All employees accepted the offer. Through the end of 20X7,

ABC estimated that 20,000 shares would still be forfeited before the completion of the requisite service period. Cumulative forfeitures were 16,000 shares as of December 31, 20X7. ABC has elected a policy to view modification accounting as applying to each individual award, and attribution as applying to the population subject to modification, which results in a Type I modification for the entire population modified. ABC recognizes compensation cost for the repurchase and resulting modification as follows:

Compensation cost recognized in 20X6 and 20X7

| | |
|--|----------------|
| Number of shares expected to vest | 80,000 |
| Grant-date fair value | <u>\$5</u> |
| Total compensation cost | \$400,000 |
| Requisite service period | <u>4 years</u> |
| Compensation cost per year recognized in 20X6 and 20X7 | \$100,000 |

Compensation cost recognized on January 1, 20X8

| | |
|--|------------------|
| Actual number of shares settled | 84,000 |
| Grant-date fair value | <u>\$5</u> |
| Actual compensation cost for vested awards | \$420,000 |
| Less: Compensation cost recognized in 20X6 and 20X7 | <u>(200,000)</u> |
| Remaining compensation cost recognized upon settlement | \$220,000 |

The journal entry to record the repurchase is:

| | Debit | Credit |
|-------------------|---------|---------|
| Compensation cost | 220,000 | |
| APIC | 452,000 | |
| Cash | | 672,000 |

While this example scenario is for employee awards, its guidance also applies to nonemployee awards, other than for the compensation cost attribution. Nonemployee award compensation cost is recognized over a vesting period, and it is recognized in the same manner as if the grantor had paid cash. See Paragraph 4.086a.

Example 5.20: Settlement of Unvested Shares – Alternative II

Assume the same facts as in Example 5.19, except that ABC Corp. has elected a policy to apply modification accounting to the population of awards modified rather than to individual awards. As shown in Example 5.19, ABC recognized \$200,000 of cumulative compensation cost before the modification. On January 1, 20X8, ABC recognizes compensation cost for the repurchase and resulting modification as follows:

Compensation cost recognized on January 1, 20X8

| | | | |
|----------|---|---------------|-----------|
| Type I | Remaining unrecognized compensation cost for 80,000 shares at the modification date (\$400,000 - \$200,000) | | \$200,000 |
| Type III | Additional shares that vest and are subject to repurchase | 4,000 shares | |
| | Fair value per share at modification date | | \$8 |
| | Additional compensation cost recognized at modification date | | \$32,000 |
| Type IV | Shares that do not vest and are not subject to repurchase, for which there is no compensation cost recognized | 16,000 shares | |

The journal entry to record the repurchase is:

| | Debit | Credit |
|-------------------|---------|---------|
| Compensation cost | 232,000 | |
| APIC | 440,000 | |
| Cash | | 672,000 |

While this example scenario is for employee awards, its guidance also applies to nonemployee awards, other than for the compensation cost attribution. Nonemployee award compensation cost is recognized over a vesting period, and it is recognized in the same manner as if the grantor had paid cash. See Paragraph 4.086a.

Q&A 5.7b: Separation Agreement Resulting in Modification Accounting for Awards

Q. Could a separation agreement in which a company makes a cash payment to an employee and concurrently cancels the employee's awards result in modification accounting?

A. Yes. While this would typically be accounted for as a settlement of the awards when the awards are vested, a company would first determine if the payment remitted is a settlement of the awards or results in a modification to the awards.

If the awards are fully vested and the cash payment is less than or equal to the fair value of the awards, then the entity recognizes the total amount paid in equity (consistent with Example 5.18). If the awards are not fully vested and their terms are such that they are not expected to vest on termination of employment, the separation agreement results in an improbable-to-probable modification. Any previously recognized compensation cost related to the unvested awards is reversed and compensation cost is recorded for the new fair value of the unvested awards. While the new assessed fair value of the unvested awards may be more or less than the termination payment remitted, the entire amount paid to settle the unvested awards is charged to compensation cost. If the termination

payment remitted is greater than the fair value of the unvested awards, the additional amount is likely considered additional compensation expense, depending on the substance of the transaction.

In some cases, a settlement could be a combination of vested and unvested awards and, therefore, only a portion of the settlement is accounted for as a modification. For example, on January 1, 20X6, a company enters into a separation arrangement whereby a cash payment of \$50,000 is remitted and any outstanding awards held by the employee are cancelled. On the date of separation, the employee holds 1,000 vested stock options each with a grant-date fair value of \$15 and a fair value of \$10 on the date of termination. In addition, the employee holds 1,000 unvested stock options with a grant-date fair value of \$8 and a fair value of \$10. The unvested options were granted on January 1, 20X5, and cliff vest after four years of service. The terms of the unvested options are such that the awards do not vest on termination.

The termination payment is accounted for as a modification of the unvested shares on the date of termination. Therefore, the company reverses any previously recognized compensation cost associated with the unvested options that are no longer expected to vest. In addition, the portion of the settlement payment remitted related to the vested shares of \$15,000 ($1,000 \times \15) is recorded to equity and the remaining portion related to the unvested shares of \$35,000 ($\$50,000 - \$15,000$) is recorded as compensation cost.

5.026b When there is a long period between an entity's startup phase and its IPO, some private companies enable transactions that permit common shareholders to sell a portion of their holdings to existing or new investors to obtain liquidity. These transactions are sometimes referred to as secondary stock offerings. Based on an entity's level of involvement, and manner in which it is involved, in a secondary offering, such transactions may require companies to recognize additional compensation cost, affect how fair value is determined for subsequent share-based payment awards, change the characterization of the transaction for tax purposes, or have other tax and accounting consequences. Also see Paragraph 1.026a, Q&A 1.21a, Q&A 2.14a, and Q&A 5.7c.

Q&A 5.7bb: Excise Tax on Repurchases if the Price Is in Excess of Fair Value

Background

The Inflation Reduction Act of 2022 (IRA) was signed into law in August 2022. Among other things, it imposed a 1% excise tax on net share repurchases made by certain publicly traded corporations during a tax year. The excise tax is based on the fair market value of repurchased shares on the repurchase date and is not accounted for as an income tax under ASC Topic 740. Instead, companies will generally account for the excise tax as a direct cost of a share repurchase transaction.

Q. Is the excise tax on repurchases of equity-classified common shares from an employee accounted for similar to other repurchases if the repurchase price is in excess of the shares' fair value?

A. Yes. An entity generally accounts for excise tax on repurchase of shares in a share-based payment arrangement similar to other repurchases of common shares. This is the case even if the common shares are repurchased for more than their fair value.

When the repurchase price (i.e., cash or other assets paid, or liabilities assumed) exceeds fair value, the excess purchase price represents compensation for prior services under ASC Topic 718. However, the excise tax is based on the fair value of repurchased shares instead of the repurchase price. Therefore, the excise tax is an additional cost of repurchasing the instrument.

For repurchases of equity-classified shares, we believe it is acceptable to recognize the excise tax in equity, similar to other repurchases of equity-classified common shares. See also KPMG Hot Topic, [Share repurchase tax Q&As](#) for further information on share repurchase tax.

For repurchases of liability-classified shares, the excise tax is recognized in the income statement, similar to other repurchase costs.

SHORT-TERM INDUCEMENTS

5.027 ASC Section 718-20-20 defines a *short-term inducement* as “an offer by the entity that would result in modification of an award to which an award holder may subscribe for a limited period of time.”

5.028 However, FASB Staff Position FAS 123(R)-6, “Technical Corrections of FASB Statement No. 123(R),” notes that the FASB did not intend for a short-term inducement that is intended to be a settlement of the award to affect the classification of the award for the period where the inducement is outstanding. As a consequence, an offer for a limited period of time to repurchase an award is excluded from the definition of a short-term inducement and is not accounted for as a modification. Instead, when award holders accept the inducement, it would be accounted for as a settlement of the award as described in Paragraph 5.026. FSP FAS 123R-6, par. 11

5.029 Neither ASC Topic 718 nor the FSP provide guidance for determining when an inducement is short-term other than to refer to a *limited time period*. Based on that description, the offer period for a short-term inducement generally should not extend beyond a few weeks.

Example 5.20a Not used.

Example 5.20b: Short-Term Inducement

On January 1, 20X9, ABC Corp. grants 100 stock options to 200 employees with an exercise price of \$15 per share option that cliff vest after four years of service. The grant-date fair value of the award is \$5 per share option.

On December 31, 20X9, ABC offers to all 200 employees a reduction in the exercise price of the stock options to \$10 if they agree to extend the vesting period for an additional year. The offer is valid for three weeks and 50 employees accept the offer during the inducement period.

ABC Corp. would apply modification accounting only to the 5,000 stock options for the 50 employees that accepted the offer because the offer meets the definition of a short-term inducement.

5.030 While a short-term offer to settle the awards is not considered to be a modification, entities with a history of settling awards for cash should consider the provisions of ASC paragraph 718-10-25-15. That paragraph states that entities that have established a pattern of cash-settling awards should classify those awards as liabilities. Therefore, an entity with a history of offering inducements to cash-settle an award would treat the share-based payment award as a liability from the date of grant.

Q&A 5.7c: Grantee Sales of Immature Shares in a Secondary Offering

Q. Could allowing grantees to exercise and immediately sell vested stock options to participate in a secondary offering establish a pattern of cash settling the share-based payment awards?

A. Yes. When the buyers in a secondary offering are determined to be acting on behalf of a company (see Paragraph 1.026a, Q&A 1.21a, Paragraph 5.026a, and Example 5.20a), and the company permits grantees to sell immature shares (generally shares owned for less than six months, but this period could be longer for non-public companies as discussed in Paragraph 3.023), consideration should be given to whether the transactions establish a pattern of cash settling the share-based payment awards. If grantees develop a reasonable expectation that the company (or an agent of the company) will buy back their stock before they have been exposed to the risks and rewards of owning the underlying stock for a reasonable period of time, liability classification for outstanding awards under the plan is required. Significant judgment is required in evaluating whether such an expectation has been established. That judgment may depend on the nature and frequency of the transactions, communications from the Board and management, and other factors.

5.031 An inducement is an offer designed to encourage holders of a share-based payment award to exercise or modify their awards. A short-term inducement results in a modification of the terms of only the awards of grantees who accept the inducement, while

other inducements result in a modification of the terms of all awards subject to the inducement, regardless of whether the award holders accept the inducement offer. The modification guidance of ASC Topic 718 would still apply to all such inducements, whether short-term or long-term in nature. However, modification accounting would be applied only to those inducements for which there is a change in fair value, vesting conditions, or the classification of the award as a result of the inducement. ASC paragraph 718-20-35-5

CANCELLATIONS

5.032 The cancellation of an award and the concurrent grant of a replacement award are accounted for in the same manner as a modification of the terms of the cancelled award. Modification accounting is applied if there is a change in the fair value or vesting conditions of the cancelled and replacement award, or a change in the classification of the cancelled and replacement award. An award that is cancelled without a replacement award or other form of consideration given to the grantee should be accounted for as a repurchase for no consideration. If an award is cancelled before the completion of the employee's requisite service period or nonemployee's vesting period, any previously unrecognized compensation cost should be recognized at the date of the cancellation. Because a cancellation is not the forfeiture of an award, previously recognized compensation cost is not reversed in connection with a cancellation. ASC paragraphs 718-20-35-8 and 35-9

Example 5.21: Cancellation of an Award and the Concurrent Grant of a Replacement

On January 1, 20X7, ABC Corp. grants 500 employee stock options with a grant date fair value of \$5 that cliff vest after four years of service. On January 1, 20X9, ABC cancels the options and concurrently issues replacement options with a service period of one year. The grant date fair value of the replacement awards is \$8 and the fair value of the cancelled awards is \$3 on the date of cancellation.

As of the date of cancellation, ABC recognized total compensation cost of \$1,250 based on the original terms of the award ($\$5 \times 500 \times 1/2$). On the date of cancellation, ABC calculates the incremental compensation cost of \$2,500 ($\$8 - \3×500). The \$2,500 incremental compensation cost is recognized over the remaining service period of the replacement options of one year. In addition, as the original awards were canceled and not forfeited, no previously recognized compensation costs is reversed and the remaining \$1,250 ($\$5 \times 500 \times 1/2$) of compensation cost related to the cancelled options is recognized over the remaining service period of one year. As a result, a total amount of compensation cost of \$5,000 ($\$2,500$ compensation cost of the original award + $\$2,500$ incremental compensation cost) will be recorded over the revised three-year service period for both the cancelled and replacement stock options.

5.033 There are two exceptions to the general rule described above that all unrecognized compensation cost should be recognized at the date of cancellation. The first is for an employee award that contains a market condition and a performance condition or a service condition (i.e., an *and* condition), and the employee's requisite service period is based on the market condition's derived service period. Paragraphs 4.113 through 4.115 provide a discussion about the attribution period for awards requiring the satisfaction of a service or performance and/or market conditions. The second is for an employee award that contains a performance or service condition that, at the time of the cancellation, is not expected to vest under its original conditions (i.e., an improbable award). See the discussion beginning at Paragraph 4.109 related to the attribution period for awards requiring the satisfaction of service or performance conditions.

5.034 For a cancelled award that contains a market condition and a performance condition or a service condition where the initial estimate of the employee's requisite service period is based on the market condition's derived service period, the appropriate accounting will depend on the facts and circumstances. The focus of the analysis will be the reason for the cancellation. It may not be appropriate to follow cancellation accounting, for example, if it has become unlikely that the market condition will be met and the cancellation is being effected to accelerate the accounting charge for the award. If the cancellation is not substantive, the unrecognized compensation cost would continue to be recognized over the original employee's requisite service period. The employee's requisite service period for such an award would not be revised unless (a) the market condition is satisfied before the end of the derived service period or (b) satisfying the market condition is no longer the basis for determining the employee's requisite service period. In addition, if other consideration such as replacement awards and/or cash is being exchanged for the cancelled awards, modification accounting should be followed. ASC paragraph 718-10-55-77

5.035 If, at the date of cancellation, an award contains a performance or service condition that was not expected to vest (improbable) based on the original vesting conditions, no compensation cost is recognized on the cancellation date. This treatment is consistent with ASC paragraphs 718-20-55-116 through 55-119 for modification of an award that contains a performance or service condition. ASC Topic 718 does not require compensation cost to be recognized on modification of an award that contains a service or performance condition, if at the date of modification the award is not expected to vest under the original vesting conditions. While a cancellation in this situation would not require further consideration of the service or performance condition, when there is a *modification* to an award that is not expected to vest under the original vesting conditions, the entity should continue to monitor the performance or service condition because, if the performance condition in the award is ultimately met, then unrecognized compensation would be recognized.

Example 5.21a: Cancellation of an Unvested Award

On January 1, 20X6, ABC Corp. grants its founder and CEO 200,000 share options with an exercise price of \$15 per share option (the current share price) that cliff vest after four

years of service. The grant-date fair value of the award is \$6 per share option. ABC will recognize compensation cost of \$300,000 ($\$6 \times 200,000 / 4$ years) per year over the four-year requisite service period.

Over the next two years, ABC's stock price drops to \$4 per share. On January 1, 20X8, the CEO voluntarily agrees to cancel all 200,000 share options that are out-of-the-money so that ABC has shares available in its Option Plan for the grant of new awards. The CEO does not receive replacement awards or other form of consideration.

The share options are considered cancelled, instead of forfeited, as the CEO's decision to return the share options was unrelated to the CEO's ability to satisfy the related service condition. In connection with the cancellation, ABC will record compensation cost of \$600,000 for the remaining amount of unrecognized compensation that would have been recognized in years 20X8 and 20X9.

5.035a The demotion of an employee could result in a cancellation, forfeiture, or modification of an award provided to that employee, and the relevant accounting for the award depends on the facts and circumstances. An entity evaluates the level of service that is expected in the employee's new role and whether the change in the level of service is significant, in addition to considering whether there are any consequential changes to the award itself by the entity. If there is a significant change in the level of service being provided by a demoted employee, an entity may modify the award accordingly, and modification accounting is applied (see Paragraph 5.008). If the change in service is not considered significant, an entity may conclude that the fair value, vesting conditions and classification of the related awards remain unchanged, and modification accounting would not be applied. However, if the employee surrenders the award in conjunction with a new role at the employer, the award may be considered cancelled or forfeited, depending on the circumstances.

Q&A 5.8: Demotion of an Employee

As part of a package to hire a new Chief Operating Officer (COO), ABC Corp. granted 100,000 nonvested common shares that cliff vest after four years of service. Six months after beginning service in that position, the employee resigned as COO but remained at the company in a new role with significantly reduced responsibilities and, therefore, significantly less compensation (i.e., the employee has been demoted within the company). The employee surrendered all rights to the nonvested shares granted under the previous employment agreement at the date of the demotion (resignation as COO). The employee's new compensation is commensurate with the compensation of others at the employee's new position and the employee is no longer eligible to participate in the entity's share-based payment plan.

Q. Should the surrender of a share-based payment in connection with the demotion be treated as a forfeiture or cancellation of the award?

A. It depends. Generally, compensation cost for an award is recognized unless the employee terminates employment before vesting. However, if the company can demonstrate that the employee was originally granted the surrendered award in connection with a specific type and level of service that will no longer be provided in the employee's new role, then surrender of the award in connection with a demotion may be considered a forfeiture of the award. This conclusion is predicated on a determination that the employee has substantially terminated employment in one capacity and been rehired as a new employee in a new role that is not eligible for the same level of share-based compensation.

Q&A 5.9: Cancellation and Issuance of Awards in Connection With the Emergence from Chapter 11

Q. Should an employee share-based payment award that is cancelled by the bankruptcy court as part of a Chapter 11 bankruptcy reorganization be treated as a cancellation?

A. Yes. The cancellation of an employee share-based payment award should be treated as a cancellation under ASC paragraph 718-20-35-9 because, in a typical bankruptcy approval process, cancelling the award is not accompanied by the concurrent grant of a replacement award. In the bankruptcy process, all equity interests, including the employee share options, are typically cancelled by the bankruptcy court before the emergence from bankruptcy. That is, the Chapter 11 reorganization plan, when confirmed by the court, terminates the shares of the company rendering shares valueless, hence resulting in the share-based payment awards being cancelled as well. Any share-based payments that the post-emergence company awards to employees frequently are granted in amounts that are not proportionate to the previous awards and are not made concurrently with the process of emerging from bankruptcy. Accordingly, the entity would record unrecognized compensation cost in its pre-emergence financial statements. The post-emergence company would treat new share-based payments as new grants.

Share-based payments issued to employees in connection with the emergence from bankruptcy where fresh-start accounting is applied in accordance with ASC Topic 852, *Reorganizations*, would be accounted for in the same manner as awards granted in conjunction with a business combination. See KPMG Handbook, *Business Combinations*.

5.035b An entity may modify or cancel an existing employee benefit arrangement accounted for under ASC Topic 710 (e.g., cash bonus plan) by issuing an equity instrument that is subject to ASC Topic 718. For example, stock options issued to an employee in place of a year-end cash bonus. If a Topic 710 liability is modified through the issuance of an equity instrument that falls under the scope of Topic 718, Topic 718 is considered for the related accounting for the original transaction along with the new stock award issuance.

Example 5.21b: Modification of Awards Previously Accounted for under ASC Topic 710

Background

On January 1, 20X1, ABC Corp. hires a new CEO and enters into a long-term incentive agreement providing a cash bonus of \$500,000 at the end of five years of service. ABC accounts for the liability under ASC Topic 710 and recognizes the related expense on a straight-line basis over the five-year service period.

On January 1, 20X3, the CEO agrees to terminate the existing long-term incentive agreement in exchange for the equivalent value in RSUs. The RSUs will vest on December 31, 20X5 in line with the original service period of the long-term incentive agreement.

As of January 1, 20X3 (date the agreement is modified), ABC Corp. had recorded cumulative compensation cost and an accrued liability of \$200,000 ($\$500,000 \times 2/5$ years of service) related to the original long-term incentive agreement.

Evaluation

While the original agreement was not within the scope of ASC Topic 718, on modifying the agreement, ABC considers the modification guidance in Topic 718 to determine the RSU award accounting. As a result, ABC will reclassify the \$200,000 liability to accumulated other comprehensive income (APIC) and the remaining \$300,000 ($\$500,000$ RSU fair value less \$200,000 previously recognized) is recognized as compensation cost over the remaining service period of 3 years.

5.035c In addition, an entity may modify or cancel existing awards under a share-based payment arrangement accounted for under ASC Topic 718 by issuing an employee benefit arrangement (e.g., cash bonus plan) that is subject to Topic 710. When this occurs, Topic 718 is considered for the modification accounting, prior to applying the Topic 710 accounting.

MODIFICATION TO ACCELERATE VESTING

5.036 An entity's share-based payment plan may be modified to accelerate vesting of outstanding unvested share-based payment awards held by grantees on the occurrence of a specified event (i.e., change in control or death, disability, or termination without cause of an employee). An entity also may modify an award to accelerate vesting that is not made in contemplation of an event's occurrence. If there is no change in fair value, vesting conditions, or the classification of the award, an entity would not apply modification accounting.

Awards Modified to Accelerate Vesting before Event Is Contemplated

5.036a A modification to accelerate vesting of an award on the occurrence of a specified event when that event is not currently contemplated does not affect the number of share-based payment awards expected to vest. As long as awards are expected to vest based on their original terms, there would be no additional compensation cost because the modification is a Type I (probable-to-probable) modification. If modification accounting is applied and the awards are not expected to vest, this would result in a Type IV (improbable-to-improbable) modification, which would be accounted for as described in Paragraph 5.009a.

Example 5.22: Addition of an Acceleration Provision for Change of Control Not in Contemplation of a Change of Control Event

On January 1, 20X5, ABC Corp. grants its CFO 200,000 share options with an exercise price of \$10 per share option (equal to the market price of the stock) that cliff vest at the end of four years of service. The grant-date fair value of the award is \$4 per share option. ABC will recognize compensation cost of \$200,000 per year ($\$4 \times 200,000$ share options / 4 years) over the four-year requisite service period. On January 1, 20X7, the board modifies the award to provide for acceleration of vesting in the event of a change in control of ABC. The modification is not made in contemplation of a change of control event. The fair value of the share options on the date of the modification is \$6. No other terms or conditions of the original award are modified and ABC continues to believe that it is probable that the share options will vest based on their original terms.

Because no other terms or conditions of the award were modified and, the modification represents a Type I (probable to probable) modification because it was not in contemplation of an event, the modification is assumed not to affect the per-share-option fair value. Accordingly, ABC will continue to recognize \$200,000 per year in compensation cost over the remaining requisite service period.

While this example scenario is for employee awards, its guidance also applies to nonemployee awards, other than for the compensation cost attribution. Nonemployee award compensation cost is recognized over a vesting period, and it is recognized in the same manner as if the grantor had paid cash. See Paragraph 4.086a.

Awards Modified to Accelerate Vesting In Contemplation of an Event

5.037 If an entity modifies an award to provide for the acceleration of vesting but does so in contemplation of an event, at the date of modification the entity would need to assess the likelihood that the original award would have vested under its original terms and under the modified terms. The original award would be evaluated to consider whether it would expire on the occurrence of the specified event (e.g., a change in control, involuntary termination, etc.). If so, the modification to add acceleration of vesting in contemplation of an event would constitute a Type III modification (perhaps for only some of the affected

grantees depending on when the contemplated event is anticipated to occur) resulting in the recognition of compensation cost based on the fair value of the modified award.

5.038 When an entity is considering modifying an award at a point in time that could be considered to be in contemplation of a business combination, the entity should consider several factors when evaluating the potential accounting for any modification that might be made to the award:

- (1) Whether the entity is actively pursuing potential targets and suitors, actively exploring strategic alternatives, or is in the initial process of strategic planning that may evolve into more specific strategic initiatives (e.g., a restructuring that would result in significant layoffs).
- (2) Complexity of estimating at the time of the modification the number of awards that would have been forfeited under the original provisions of the awards. Even if an entity's accounting policy is to account for forfeitures when they occur, the entity is required to assess at the date of the modification whether the service and/or performance conditions of the original award are expected to be satisfied. The estimate of forfeitures related to the original award is required when there is a modification since that estimate can affect the cumulative compensation cost to be recognized depending on an entity's policy election for the unit of account for modifications (see Paragraph 5.009 and 5.009a). In addition, an entity's policy election for estimating forfeitures or recognizing them as they occur will apply when it subsequently accounts for the modified award. See Paragraph 5.009a for further discussion. The complexity of estimating the number of awards that would have been forfeited under the original provisions of the awards increases when the entity is in the beginning phase of contemplating an event that is expected to invoke the modified term;
- (3) Difficulties in supporting certain inputs to the fair value measurement of the modified awards (e.g., expected term, expected volatility).

5.039 There would be reduced complexity involved in determining whether a modification is made *in contemplation* of a business combination or other event and, if so, determining what portion of the awards are deemed to be improbable-to-probable modifications (i.e., for the portion of the awards no longer expected to vest under the original terms), if the modification to add an acceleration of vesting provision is made at a time when there are no such events currently under consideration by management or the board. There also would be reduced complexity if the modification is made immediately before consummation of a specific transaction to modify the award. Paragraphs 11.042 through 11.045 of KPMG Handbook, *Business Combinations*, describe additional considerations for modifications of awards in contemplation of a change in control.

Example 5.23: Adding an Acceleration Provision Made in Contemplation of an Employee Termination Without Cause

On January 1, 20X5, ABC Corp. grants 200,000 share options with an exercise price of \$10 per share option (equal to the market price of the stock) that cliff vest after four years of service. The grant-date fair value of the award is \$4 per share option. ABC will recognize compensation cost of \$200,000 per year ($\$4 \times 200,000$ share options / 4 years) over the four-year requisite service period. On January 1, 20X8, the board modifies the award to provide for acceleration of vesting if an employee is terminated without cause. The modification is made in contemplation of a company-wide restructuring. The fair value of the share options on the modification date is \$7. No other terms or conditions of the original award are modified. On January 31, 20X8, 200 employees holding a total of 125,000 share options are terminated and the share options vest.

Because the award is modified to add an acceleration provision in contemplation of the employee terminations,¹ and therefore, the vesting conditions are modified, the awards are accounted for under modification accounting. The modification is deemed to be a Type III modification for those awards that were expected to be forfeited under the original terms of the award. Thus, the fair value of the modified award will be the total compensation cost recognized.

ABC would recognize compensation cost as follows:

Compensation Cost Recognized in Years 20X5, 20X6, and 20X7

| | | |
|---|---|-----------|
| Number of share options expected to vest that were modified | | 125,000 |
| Grant-date fair value | × | \$4 |
| Total compensation cost | | \$500,000 |
| Requisite service period | / | 4 years |
| Compensation cost per year | | \$125,000 |
| Service provided to date | × | 3 years |
| Compensation cost recognized to date | | \$375,000 |

Compensation Cost to Recognize for Modified Award

| | | |
|--|---|-----------|
| Number of share options that vest on restructuring | | 125,000 |
| Fair value per modified award | × | \$7 |
| Total fair value of modified awards | | \$875,000 |
| Less: Compensation cost previously recognized (see above) | | (375,000) |
| Compensation cost to recognize over the period from the modification date to the termination date (i.e., the revised requisite service period) | | \$500,000 |

20X8 – Awards not affected by modification

| | | |
|---|---|-----------|
| Remaining number of share options expected to vest under original terms | | 75,000 |
| Grant-date fair value | × | \$4 |
| Total compensation cost | | \$300,000 |
| Requisite service period | / | 4 years |
| Compensation cost for 20X8 | | \$75,000 |

¹ An entity's estimate of employee terminations is based on the entity's best available information at the time of the modification. In addition, the estimate of terminations is not adjusted for changes in estimate or for actual terminations that occur subsequent to the modification date if those amounts differ from the estimates made on the modification date.

Example 5.24: Adding an Acceleration Provision Made in Contemplation of a Change in Control

On January 1, 20X5, ABC Corp. grants 100,000 share options with an exercise price of \$15 per share option (equal to the market price of the stock) that cliff vest after four years of service. The grant-date fair value of the award is \$6 per share option. ABC's accounting policy is to estimate the number of forfeitures and to include that estimate in its initial accrual of compensation cost. ABC expects 95% of the share options to vest. ABC will recognize compensation cost of \$142,500 per year ($\$6 \times 100,000$ share options \times 95% expected to vest / 4 years) over the four-year requisite service period. On January 1, 20X7, the board modifies the award to provide for acceleration of vesting in the event of a change in control. As the vesting conditions have been revised, the awards are accounted for using modification accounting. The fair value of the share options on the modification date is \$7. No other terms or conditions of the original award are modified. At the time the awards are modified, ABC is in final merger negotiations, which, if consummated, would be a change of control event as defined by the newly modified awards. The merger is consummated on January 2, 20X7.

At the date of the modification, because it was made in contemplation of a change of control event, ABC must determine what portion of the original award recipients is still expected to vest under the original terms of the award (i.e., to remain employed for four years from the grant date). For those employees, the modification is a Type I modification (probable-to-probable) and would not result in a change in compensation cost recognized (i.e., the grant-date fair value of \$6 would continue to be recognized for these employees). For those employees that are no longer expected to vest under the original terms of the award, taking into consideration the contemplated change of control event, the modification is a Type III modification (improbable-to-probable). In this situation, because the awards would have been forfeited on the change of control, for these employees, the compensation cost recognized would be based on the \$7 fair value as of the date the awards are modified.

Even if ABC's accounting policy was to account for forfeitures when they occur, ABC would still be required to assess at the date of the modification whether the service condition of the original awards are expected to be satisfied. The estimate of forfeitures related to the original award is required when there is a modification, since that estimate affects the cumulative compensation cost to be recognized (i.e., whether compensation cost will be based on the grant date fair value of \$6 or the \$7 fair value as of the date the awards are modified). However, an entity's policy election for forfeitures will apply when it subsequently accounts for the modified award. See Paragraph 5.000 for further discussion.

Examples 11.21 and 11.22 of KPMG Handbook, *Business Combinations*, provide additional illustrations of modifications to add acceleration of vesting provisions to share-based payment awards.

While this example scenario is for employee awards, its guidance also applies to nonemployee awards, other than for the compensation cost attribution. Nonemployee award compensation cost is recognized over a vesting period, and it is recognized in the same manner as if the grantor had paid cash. See Paragraph 4.086a.

Q&A 5.10: Modification Made in Contemplation of an Event

Q. The original terms of an award provide that if an employee is terminated without cause, the plan allows a participant to exercise vested share options within 90 days of termination. The company is contemplating a restructuring, and therefore is considering an amendment to the share option plan to allow terminated employees up to 240 days from the date of termination to exercise vested awards. Should the expected share option terms for the employees expected to be terminated as part of the restructuring be revised in accounting for the modification even though the restructuring has not yet been finalized?

A. Yes. Under ASC paragraph 718-20-35-3(a), incremental compensation cost is measured as the excess of the fair value of the modified award over the fair value of the original award immediately before the terms are modified based on the share price and other pertinent factors at that date. In this case, the pertinent factor is the increase in the expected term of the share option of up to 150 days. Therefore, there will be incremental compensation cost because of the increased time value of the awards due to the lengthened period of time to exercise vested awards. Because the awards are fully vested at the date of the modification, the incremental compensation cost would be immediately recognized at the date of the modification.

EQUITY RESTRUCTURINGS

Awards That Contain Anti-Dilution Provisions as Part of Existing Terms

5.040 Share-based compensation plans frequently contain anti-dilution provisions that in the event of an equity restructuring (e.g., a stock dividend, stock split, spin-off, rights offering, or recapitalization), the terms of all outstanding awards are adjusted so that the holder is in the same economic position after the equity restructuring as before. For an award with an anti-dilution provision, the modification to the terms of an award in connection with an equity restructuring does not result in the recognition of any incremental compensation cost, as long as there is no change in fair value, vesting conditions, or the classification of the award immediately before and after the restructuring. ASC paragraph 718-20-35-6

5.041 For awards that contain anti-dilution provisions, a modification to the terms of an award occurs when the provisions are activated in conjunction with an equity restructuring, even though the provision is part of the existing terms of the awards. However, the modification does not result in the recognition of any incremental compensation cost if there is no change in fair value, vesting conditions, or the classification of the award immediately before and after the restructuring. The incremental compensation, if any, is measured as the excess of the fair value of the post-modified award over the fair value of the award before the modification. (ASC paragraph 718-20-35-6) The fair value of the award before the modification is determined using the entity's normal valuation method (e.g., Black-Scholes-Merton) based on inputs that are appropriate on the modification date and assuming that the equity restructuring will occur. An anti-dilution provision designed to make equitable adjustments based on fair values generally will not result in incremental compensation.

Example 5.25: Equity Restructuring with Awards That Contain Anti-Dilution Provisions

On January 1, 20X6, ABC Corp. grants 30,000 share options with an exercise price of \$40 per share option (the current share price) that vest ratably over two years of service. The grant-date fair value is \$15 per share option. The awards contain standard anti-dilution provisions that automatically adjust, through applying specified ratios, the exercise price and number of share options in a manner that will equalize the value to the option holder in the event of a stock split.

Over the past several years, ABC's stock price has increased dramatically due to the success of a new product launch. On March 15, 20X8, ABC's board of directors announces a 5-for-1 stock split for shareholders of record on April 15, 20X8. The ex-dividend date (when ABC's shares will trade on a post-split basis) will be April 20, 20X8.

On April 19, 20X8, ABC's shares close at \$80 per share (pre-split). After the market closes, the stock exchange adjusts the closing price of ABC's shares to \$16 (\$80 adjusted for the 5-for-1 split). Immediately prior to the split, 30,000 share options were still outstanding. The following table summarizes the number of share options, exercise price, and fair value of the awards immediately before and after the modification (the fair value of the pre-split awards reflects the anticipated effects of the contemplated equity restructuring and the anti-dilution provision).

| | Pre-Split | Post-Split |
|-----------------------------------|----------------------|----------------|
| Number of shares | 150,000 ¹ | 150,000 |
| Exercise price | \$8 | \$8 |
| Current share price | \$16 | \$16 |
| Fair value per share option | \$9 | \$9 |
| Total fair value of share options | \$1.35 million | \$1.35 million |

¹ For purposes of determining fair value for the pre-split awards, the current share price reflects the contemplated equity restructuring and the number of share options and the exercise price reflects the effects of the anti-dilution provision.

Because the fair value, vesting conditions, and classification of the awards are the same immediately before and after the equity restructuring, there is no incremental compensation cost associated with modification to the terms of the award.

Example 5.26: Modification of Awards That Contain Anti-Dilution Provision with a Partial Cash Settlement in Connection with Equity Restructuring

Background

On January 1, 20X6, ABC Corp. grants 10,000 share options with a grant-date fair value of \$15 per share option. The share options cliff vest after three years of service. The share options contain an anti-dilution provision that requires ABC to make an equitable adjustment to the option holders in the event of defined equity restructuring events. On December 31, 20X7, ABC issues \$10 million of debt and uses the net proceeds to pay an extraordinary dividend to all shareholders. The extraordinary dividend requires an equitable adjustment to the option holders under the anti-dilution provision of the award. ABC does so by a combination of a reduction in the exercise price and a cash payment to the option holders.

The share options have a fair value of \$25 per share option immediately before the equity restructuring. Post-equity restructuring, the share options have a fair value of \$20 per share option (including the reduction of the exercise price). Additionally, a cash payment of \$5 per option holder was made so that the total fair value of the award post-equity restructuring equals the pre-equity restructuring fair value.

Evaluation

On December 31, 20X7, the date of the equity restructuring, ABC compares the fair value, vesting conditions and classification of the awards pre- and post- equity restructuring to determine if modification accounting is applied.

The anti-dilution provision was included in the original terms of the share option agreement and the modification to effect the anti-dilution provision keeps the option holder in the same economic position pre- and post-equity restructuring. However, at the date of the equity restructuring, the option holders had provided two-thirds of the requisite service. The grant-date fair value of the share options was \$15 per share option for the 10,000 share options for a total grant-date fair value of \$150,000. Therefore, \$50,000 ($1/3 \times \$150,000$) of the grant-date fair value is unrecognized at the equity restructuring date.

The change to the share options is made by reducing the exercise price and adding a cash payment. The cash payment element of the equity restructuring represents a settlement of a portion of the award. Therefore, the vesting conditions are not the same pre- and post-equity restructuring. Thus, modification accounting is applied, and compensation cost related to the cash settlement portion is recognized at that date.

There is no authoritative guidance as to how the deemed settled portion of the award is to be determined and practice may vary. We believe one acceptable method is to allocate the amount proportionately between the earned and unearned portions based on the elapsed service to date and the portion of the award settled in cash. In this example, the cash settlement of \$5 represents 20% of the fair value of the award immediately after the modification (\$5 cash payment + \$20 fair value of modified share options = \$25). Accordingly, \$10,000 (20% of the remaining unrecognized compensation cost of \$50,000) compensation cost is recognized at the date of the equity restructuring.

Alternatively, ABC could determine the compensation cost to record, as of the modification date, based on 20% of the entire award that is no longer subject to forfeiture (this would be considered the earned portion of the award, since the employees get to keep the cash whether or not the awards ultimately vest). This is summarized as follows:

| | | |
|--|-----------|-----------|
| Grant Date Fair Value | | \$150,000 |
| Portion of the award “settled” by virtue of cash payment | 20% | |
| Grant Date Fair Value of Settled Portion | | \$30,000 |
| Grant Date Fair value of Remaining Portion | \$120,000 | |
| Proportion earned to date (2 of 3 years of service) | 2/3 | \$80,000 |
| Total compensation cost to date | | \$110,000 |
| Remaining unrecognized cost ($\$120,000 \times 1/3$) | \$40,000 | |

While this example scenario is for employee awards, its guidance also applies to nonemployee awards, other than for the compensation cost attribution. Nonemployee award compensation cost is recognized over a vesting period, and it is recognized in the same manner as if the grantor had paid cash. In this example for nonemployee awards, the amount of services received and/or goods provided by the nonemployee would need to be considered, instead of the requisite services provided for employee awards. See Paragraph 4.086a.

Awards Modified to Add an Anti-Dilution Provision Not Made in Contemplation of an Equity Restructuring

5.042 In accordance with ASC paragraph 718-20-35-2A, if an award is modified to add an anti-dilution provision that is not made in contemplation of an equity restructuring, a comparison of the fair value of the modified award and the fair value of the original award immediately before the modification is not required as the modification does not affect any of the inputs to the valuation technique that is used to value the award. As a result, we would expect no incremental compensation cost to be recognized. However, as described in Paragraph 5.047, there can be significant tax consequences to the holder if such provisions are added to the award.

Awards Modified to Add an Anti-Dilution Provision Made in Contemplation of an Equity Restructuring

5.043 If an award is modified to *add* an anti-dilution provision and that modification is made in contemplation of an equity restructuring, there would be a comparison of the fair value, vesting conditions and classification of the award pre- and post-modification on the date of the modification, taking into account the effect of the contemplated restructuring on the value of the award. This treatment is a significant departure from the guidance in Interpretation No. 44, under which no compensation was recognized if certain conditions were met without regard to whether or not a modification of an award was made in contemplation of an equity restructuring. Under ASC Topic 718, the fair value of the pre-modified award would not include adjustments to the award for the anti-dilution provision. Therefore, the fair value of the pre-modified award would be determined using the value that would have resulted had the equity restructuring occurred but the award not been modified. If the addition of the anti-dilution provision gives rise to a change in fair value, vesting conditions, or the classification of the award, the incremental value transferred, if any, would be recognized as additional compensation cost. In many cases, the incremental compensation will be significant. ASC paragraph 718-20-55-104

5.044 The addition of the anti-dilution provision may result in one or two modification events. If an entity modifies the awards simultaneously with the equity restructuring event, there is one modification.

Example 5.27: Adding an Anti-Dilution Provision in Contemplation of an Equity Restructuring Resulting in One Modification

Assume the same facts as in Example 5.25, except that ABC Corp.'s Share Option Plan does not contain an anti-dilution provision.

On April 20, 20X8, the date of the stock split, the board adds an anti-dilution provision to its Plan that affects all outstanding awards. Because the anti-dilution provision is added in contemplation of the equity restructuring, the fair value of the award pre- and post-equity restructuring would be compared to determine whether the entity should account for the effects of the modification. In this example, the vesting conditions and classification of the awards have not changed. The fair value of the pre-modified award considers the effect of the contemplated equity restructuring but does not reflect the effect of the anti-dilution provision, because the original award did not contain an anti-dilution provision. If there is incremental fair value from the addition of the anti-dilution provision, that incremental amount is recognized as compensation cost.

The following table summarizes the number of share options, exercise price, and fair value of the awards immediately before and after the modification.

| | Pre-Modification | Post-Modification |
|-----------------------------------|-------------------------|--------------------------|
| Number of share options | 30,000 | 150,000 |
| Exercise price | \$40 | \$8 |
| Current share price | \$16 ¹ | \$16 |
| Fair value per share option | \$0.50 | \$9 |
| Total fair value of share options | \$15,000 | \$1,350,000 |

¹ For purposes of determining fair value of the pre-modified awards, the current share price reflects the effect of the contemplated equity restructuring. The number of share options and the exercise price do not reflect the effects of the anti-dilution provision because the original award did not include the anti-dilution provision.

Incremental compensation from modification related to equity restructuring

| | |
|--|-----------------|
| Post-modification fair value | \$1,350,000 |
| Pre-modification fair value | <u>(15,000)</u> |
| Incremental compensation cost recognized from modification related to equity restructuring | \$1,335,000 |

The compensation cost would be recognized immediately because the awards are fully vested.

5.045 In other circumstances, adding an anti-dilution provision in contemplation of an equity restructuring results in two modifications when an entity adds an anti-dilution provision to an award in contemplation of, but prior to the actual equity restructuring. The

first modification would occur when the entity adds the anti-dilution provision to the award and the second modification occurs when the equity restructuring occurs. Each modification is separately evaluated to determine whether there is incremental compensation cost to recognize.

Example 5.28: Adding an Anti-Dilution Provision in Contemplation of an Equity Restructuring That Results in Two Modifications

Assume the same facts as in Example 5.25, except that ABC Corp.'s Share Option Plan does not contain an anti-dilution provision.

On March 15, 20X8, when the stock price was \$70, the board announces the stock split and ABC adds an anti-dilution provision to its Plan that affects all outstanding awards. The stock split will take place on April 20, 20X8. Because the anti-dilution provision is added in contemplation of the restructuring and prior to the equity restructuring event (i.e., the stock split), there are two modifications. The first modification is the addition of the anti-dilution provision to the award. The second modification is the equity restructuring event.

For the first modification, the fair value of the award pre- and post-modification is compared to determine whether the entity should account for the effects of the modification. In this example, the vesting conditions and classification of the awards have not changed. The fair value of the pre-modified award reflects the effect of the contemplated restructuring but does not reflect the effects of the anti-dilution provision because the original award did not contain the anti-dilution provision. If there is incremental fair value from the addition of the anti-dilution provision, that incremental amount is recognized as compensation cost.

The following table summarizes the number of share options, exercise price, and fair value of the awards immediately before and after the modification.

| | Pre-Modification | Post-Modification |
|-----------------------------------|-------------------------|--------------------------|
| Number of share options | 30,000 | 150,000 |
| Exercise price | \$40 | \$8 |
| Current share price | \$14 ¹ | \$14 |
| Fair value per share option | \$0.50 | \$7 |
| Total fair value of share options | \$15,000 | \$1,050,000 |

¹ For purposes of determining fair value of the pre-modified awards, the current share price reflects the effect of the contemplated equity restructuring. The number of share options and the exercise price do not reflect the effects of the anti-dilution provision because the original award did not include the anti-dilution provision.

Incremental compensation from modification related to equity restructuring

| | |
|--|-----------------|
| Post-modification fair value | \$1,050,000 |
| Pre-modification fair value | <u>(15,000)</u> |
| Incremental compensation cost recognized from modification related to equity restructuring | \$1,035,000 |

Such compensation cost would be recognized immediately because the awards are fully vested.

On April 19, 20X8, ABC's shares close at \$80 per share (pre-split). After the market closes, the exchange adjusts the closing price of ABC's shares to \$16 (\$80 adjusted for the 5-for-1 split). Immediately before the split, 30,000 share options were still outstanding. When the actual equity restructuring takes place on April 20, 20X8, ABC will have the second modification of the award and will need to compare pre- and post-modification values to determine whether any incremental value is transferred as a result of the second modification. If there is no change in fair value, vesting conditions, and the classification of the award, the entity would not account for the effect of the modification on April 20, 20X8. If there is a change in fair value, vesting conditions, or the classification of the award, the incremental value transferred, if any, would be recognized as additional compensation cost. The following table summarizes the number of share options, exercise price, intrinsic value, and fair value of the awards immediately before and after the modification noting that the fair value of the pre-split awards considers the effects of the contemplated equity restructuring and the anti-dilution provision.

| | Pre-Split | Post-Split |
|-----------------------------------|----------------------|-------------------|
| Current share price | \$16 | \$16 |
| Number of share options | 150,000 ¹ | 150,000 |
| Exercise price | \$8 | \$8 |
| Fair value per share option | \$9 | \$9 |
| Total fair value of share options | \$1,350,000 | \$1,350,000 |

¹ For purposes of determining fair value for the pre-split awards, the current share price reflects the contemplated equity restructuring and the number of share options and the exercise price reflects the effects of the anti-dilution provision.

Because the fair value, vesting conditions and classification of the award is the same immediately before and after the equity restructuring, there is no incremental compensation cost associated with the second modification resulting from the equity restructuring.

Example 5.29: Adding an Anti-Dilution Provision with a Partial Cash Settlement in Connection with Equity Restructuring

Background

On January 1, 20X6, ABC Corp. grants 100,000 share options with a grant-date fair value of \$5 per share option that cliff vest after five years of service. The awards do not contain an anti-dilution provision. On December 31, 20X7, ABC issues \$10 million of debt and uses the net proceeds to pay an extraordinary dividend to all shareholders. ABC modifies the terms of its share option awards in conjunction with the payment of the extraordinary dividend and commits to pay a cash payment to the option holders of \$2 per share option when the share options vest. The fair value of the award after the modification is \$10, which is comprised of the cash dividend payable on vesting of \$2 per share option and a share option value of \$8 for the modified awards. As the fair value has changed pre- and post-equity restructuring, modification accounting would be applied to the awards.

Evaluation

Because of the modification to the share options, the fair value of the award pre- and post-modification would be compared with the excess constituting additional compensation cost as described in Example 5.28. Additionally, because a portion of the economic value of the modified share options will be paid in cash, the modified award would be treated as a combination award (i.e., one award (share option) is treated as an equity-classified award and the other award (dividend payment) is treated as a liability-classified award).

In this example, 20% of the modified award would be liability-classified and would be subject to remeasurement until the awards are settled (however, there would be no remeasurement because the liability-classified portion is a fixed amount of \$2 per share option). The remaining 80% of the award would be equity-classified.

Discretionary Modifications Related to Equity Restructurings

5.046 Some awards contain anti-dilution provisions that permit, but do not require, awards' terms to be modified. If an entity exercises its discretion and modifies awards in conjunction with an equity restructuring, the modification would be accounted for the same as if the anti-dilution provisions were added in contemplation of the equity restructuring (see Examples 5.27 and 5.28), and would be likely to result in significant incremental compensation. In contrast, some plans require an equitable adjustment but do not specify how the adjustment would be determined. In those situations, any modification would be determined as described in Example 5.25. If the adjustment conveys additional value to the award holders, additional compensation cost would be recognized.

Example 5.30: Accounting Treatment if Management’s Percentage Ownership Interest Remains Consistent Before and After an Equity Restructuring

Background

On January 1, 20X6, ABC Corp. cancels all of its existing debt and equity instruments and in exchange issues new common shares. The holders of the extinguished debt are not related parties. The ownership interests of the former equity holders are diluted except for management, which received a sufficient number of new common shares such that their percentage ownership interest remains the same before and after the equity restructuring (the original award plan for management’s awards contained an anti-dilution provision). Management did not contribute any proceeds or incur any costs in connection with the transaction.

Evaluation

For no consideration, management received a sufficient number of equity instruments to retain its ownership percentage even though the issuance of new shares to extinguish debt would otherwise have led to dilution. Unless there is evidence to the contrary, the excess shares received by management (i.e., those shares needed to offset the effects of dilution), represent compensation for employee-related services. ABC would recognize compensation cost for the fair value of the excess common shares provided to management to avoid dilution.

Tax Considerations

5.047 Depending on how the modification is structured, there can be significant tax consequences to both the entity and the employees, even for modifications that do not result in the application of modification accounting, or for modifications, after the application of modification accounting, that result in no compensation consequence (e.g., modifications to add an anti-dilution provision not made in contemplation of an equity restructuring). Modifications of awards can trigger personal income taxes, excise taxes, and interest to employees upon vesting of awards. Additionally, the modifications can result in disallowance of tax deductions on exercise of stock options and vesting of nonvested shares to an entity. There also could be tax consequences to nonemployees, when modifying nonemployee awards. *As such, entities should consider consulting with a tax professional when considering adding anti-dilution provisions to their awards or when deciding how to modify awards that require an equitable adjustment but provide latitude as to how to accomplish that objective.* See KPMG Handbook, Accounting for Income Taxes, [Section 8](#), *Income Tax Issues Associated with Share-Based Payment Arrangements*, for further guidance.

AWARDS MODIFIED IN CONNECTION WITH A SPIN-OFF

5.048 Anti-dilution provisions related to equity restructuring events frequently include spin-offs as a defined equity restructuring event. In the event of a spin-off, an entity may make a number of changes to share option terms to maintain the economic interest of option holders. These changes may include one or more of the following:

- (1) A reduction to the exercise price of share options;
- (2) An increase in the number of share options;
- (3) A grant of share options in the spinee;
- (4) An exchange of spinor options for spinee options;
- (5) The issuance of stapled share options (stapled share options entitle the holder to retain share options in the spinor and receive an equivalent number of spinee share options based on the ratio of spinee shares distributed to spinor shareholders in the spin-off); or
- (6) Cash payments to option holders.

5.049 The adjustment to an award in conjunction with a spin-off would not affect the compensation cost to be recognized for the award if the adjustment is made pursuant to an existing anti-dilution provision in the award, as long as there is an equitable adjustment to the option holders. However, the entity should evaluate the fair value, vesting conditions, and the classification of the awards pre- and post-spin to determine whether any incremental fair value has been conveyed to the option holders.

5.050 Consistent with guidance previously provided by the SEC staff, the spinor's stock price immediately before and after the distribution of the spinee's shares should be used in determining the fair value of the awards pre- and post-spin. The fair value of the spinor's stock immediately after the modification should be based on the closing price on the distribution date, adjusted to reflect the distribution of the spinee's shares (no adjustment is necessary if the spinor's stock price is quoted on an *ex-dividend* basis as described below). In many cases, the distribution of the spinee shares occurs after the exchange closes. In these situations, the closing price of the spinor's shares on the distribution date is used as the fair value of the stock immediately before the modification.

5.051 In many cases, the spinor's stock will begin trading on an ex-dividend basis a few days before the distribution date. As a result, on the distribution date, the spinor's stock price may already exclude the value of the spinee. If this occurs and the spinee's stock is trading on a *when issued* basis, the fair value of the spinor's stock immediately before the modification is based on the distribution-date closing price of the spinee's stock, which is added to the market price of the spinor's stock to determine the fair value of the stock immediately before the modification. However, if the spinor's stock is trading *with due bills* (i.e., with rights to the dividend of spinee stock), then that closing stock price should be used.

5.052 The fair value of the spinee's stock immediately after the modification should be based on the closing price of the stock on the distribution date, if traded on a when-issued basis. If the spinee's stock is not traded on a when-issued basis before the distribution date, the fair value of the stock immediately after the modification should be the opening price on the first trading date following the distribution date.

Q&A 5.11: Attribution of Compensation Cost When Spinor Awards are Exchanged for Spinee Awards

Background

ABC Corp. spins off a former subsidiary to form DEF Corp. In conjunction with the spin-off, employees of ABC's former subsidiary that are now full time employees of DEF have their outstanding ABC awards (both vested and unvested) exchanged for DEF awards. The employee's service to ABC's former subsidiary is uninterrupted by the spin off. The award agreement includes anti-dilution provisions.

Q. How do ABC and DEF recognize the remaining unrecognized compensation cost of the unvested awards after the spin-off?

A. ABC and DEF should recognize compensation cost for the respective portion of the awards that is held by their employees. ABC does not reverse previously recognized compensation cost. Once ABC employees become DEF employees, ABC should cease recognizing compensation cost and DEF should begin recognizing compensation cost based on the terms and the antidilution provisions of the awards.

If the new DEF awards have incremental fair value when compared to the original ABC awards, the incremental fair value should be recognized as compensation cost prospectively in DEF's financial statements over the requisite service period.

Q. If employees of DEF hold vested ABC options at the spin-off date that are exchanged for vested DEF options, how is any incremental value as a result of the modification accounted for?

A. ABC would recognize any incremental fair value resulting from the modification immediately in its financial statements. As no remaining requisite service is required, DEF would not recognize any compensation cost.

Section 6 - Income Tax Issues Associated with Share-Based Payment Arrangements

See KPMG Handbook, *Accounting for Income Taxes*, Section 8, Income Tax Issues Associated with Share-Based Payment Arrangements.

Section 7 - Disclosures and Earnings per Share

Detailed Contents

Disclosure Objectives for Arrangements with Grantees

Q&A 7.1: Disclosures Required in the Stand-Alone Financial Statements of the Subsidiary

Q&A 7.1a: Additional Disclosures Required for Nonemployee Awards

Minimum Disclosure Requirements

Description of Share-Based Payment Arrangements

Information for the *Most Recent Year* for Which an Income Statement Is Provided

Example 7.1: Current Year Information for Share Award Instruments

Information for *Each Year* for Which an Income Statement Is Provided

Example 7.2: Disclosure Required for *All* Annual Reporting Periods

Q&A 7.2: Applying Annual Disclosures Requirements to Modified Awards

Q&A 7.2a: Disclosures for Modified Awards Not Requiring Modification Accounting

Information as of the Date of the Latest Statement of Financial Position

Example 7.3: Fully Vested Share Options, and Share Options Expected to Vest – Information Required as of the Date of the Latest Statement of Financial Position

Q&A 7.3: Separate Entity-Wide Policy Elections for Employees and Nonemployees and Related Disclosures

Cash Flow Information

Example Disclosures

Example 7.8: Footnote Disclosures

Supplemental Disclosures

Q&A 7.4 Disclosures in its Interim Financial Statements

Example 7.9: Interim Disclosure of Significant Share-Based Payment Compensation

Disclosures Related to the Valuation of Private Company Shares

Earnings per Share

DISCLOSURE OBJECTIVES FOR ARRANGEMENTS WITH GRANTEES

7.000 ASC Topic 718, *Compensation--Stock Compensation*, establishes disclosure objectives, with an overall requirement that an entity disclose all material information related to share-based payment arrangements. For arrangements with grantees (which includes both employees and nonemployees), the disclosure objectives are for an entity to disclose information to enable users of the financial statements to understand:

- The nature and terms of the arrangements that existed during the reporting period and the potential effects of those arrangements on shareholders;
- The effect of compensation cost arising from share-based payment arrangements on the income statement;
- The method of estimating the fair value of the equity instruments granted during the period; and
- The cash flow effects resulting from share-based payment arrangements.

ASC paragraph 718-10-50-1; Statement 123(R), par. B231

7.001 If an entity has multiple share-based payment arrangements with grantees, it should disclose information separately for each different type of arrangement. Examples for which separate disclosure may be needed include share option awards with fixed exercise prices versus those with exercise prices linked to a performance index; arrangements if some awards are equity-classified and others are liability-classified; and awards that depend on fulfilling different vesting or exercisability criteria (e.g., some awards have service conditions, some awards have performance conditions, and some awards have market conditions). ASC paragraph 718-10-50-2(g)

7.002 Not used.

Q&A 7.1: Disclosures Required in the Stand-Alone Financial Statements of the Subsidiary

Q. Are the disclosures required by ASC Topic 718 applicable to the stand-alone financial statements of the subsidiary if the subsidiary has not issued share-based awards but its employees or nonemployees participate in share-based awards granted by the subsidiary's parent company?

A. Yes. The subsidiary is required to make the disclosures required by ASC Topic 718. The subsidiary should reflect in its stand-alone financial statements the share-based arrangements that the parent has granted to its grantees including the related compensation cost and all required disclosures with respect to those grants.

Q&A 7.1a: Additional Disclosures Required for Nonemployee Awards

Q. Are specific disclosures required for nonemployee share-based payment awards?

A. No. Specific disclosures are not prescribed for nonemployee awards; however, existing disclosure requirements of ASC Topic 718 also apply to nonemployee awards.

In general, a company is required to separately disclose information related to share-based payment transactions if this information is necessary to understand their effect on the financial statements. While there is no specific provision for a company to separately disclose agreements with nonemployees, if the information is important to understanding their effect, separate disclosure should be provided.

See Q&A 7.3 on entity-wide policy disclosures for nonemployee awards.

MINIMUM DISCLOSURE REQUIREMENTS

7.003 To achieve the disclosure objectives, a reporting entity, at a minimum, is required to disclose certain qualitative and quantitative information with respect to its share-based payment arrangements and certain information related to those arrangements on its cash flows. These minimum disclosure requirements are discussed in this section; however, in certain cases the disclosures provided may need to go beyond the items prescribed in this section to keep the financial statements from being misleading (e.g., disclosures about whether the entity used only implied volatility, only historical volatility, or a weighting of both). 718-10-50-1 and 2, S99-1; Statement 123(R), par. A240 f, fn 136

7.003a The disclosure requirements described in paragraphs 718-10-50-1 and 2 apply only to annual financial statements, and are not explicitly required in interim financial statements. Interim financial statements are required to contain the disclosures specified in ASC Topic 270. Also see Q&A 7.4.

Description of Share-Based Payment Arrangements

7.004 A reporting entity is required to provide a description of the share-based payment arrangement(s), including the terms of awards under the arrangement(s), such as:

- The employee's requisite service period(s) and, if applicable, the nonemployee's vesting period;
- Other substantive conditions, including those related to vesting;
- The maximum contractual term of equity (or liability) share options or similar instruments; and
- The number of shares authorized for awards of share options or other equity instruments.

7.005 An entity also should disclose the method it uses (i.e., whether it is using the fair value, calculated value, or intrinsic value method) for measuring cost from share-based payment arrangements. ASC paragraphs 718-10-50-2(a) and 50-2(b)

7.006 Additionally, other relevant information, such as exercisability conditions, should be provided.

7.007 A reporting entity also should provide a description of its policy, if any, for issuing shares upon share option exercise (or share unit conversion), including the source of those shares (e.g., whether they will come from new shares to be issued, from treasury shares already held, or treasury shares to be reacquired). If, as a result of its policy, a reporting entity expects to repurchase shares in the following annual period, the entity should disclose the expected number of shares anticipated to be repurchased during the period. ASC paragraph 718-10-50-2(l)

7.007a An entity discloses the policy choice made for either estimating expected forfeitures or recognizing forfeitures as they occur. ASC paragraph 718-10-50-2(m)

INFORMATION FOR THE MOST RECENT YEAR FOR WHICH AN INCOME STATEMENT IS PROVIDED

7.008 For the most recent year for which income statement information is reported, an entity should provide detailed information for share options, share units, nonvested shares, or other equity instruments used to provide share-based payment awards. The specific information required to be presented is summarized in Example 7.1.

Example 7.1: Current Year Information for Share Award Instruments

| Share Options (or Share Units, if Applicable) | Number | Weighted-Average Exercise Price (or Conversion Ratio) |
|--|---------------|--|
| Outstanding at beginning of the year | X | X |
| Changes during the year: | | |
| Granted | X | X |
| Exercised or converted | (X) | X |
| Forfeited | (X) | X |
| Expired | (X) | X |
| Outstanding at end of the year | X | X |
| Exercisable or convertible at end of the year | X | X |

| Other Equity Instruments ¹ | Number | Weighted-Average Grant Date Fair Value ² |
|---|--------|---|
| Outstanding at beginning of the year | X | X |
| Changes during the year: | | |
| Granted | X | X |
| Vested | (X) | X |
| Forfeited | (X) | X |
| Outstanding at end of the year | X | X |

¹ For example, nonvested shares.
² Alternatively, calculated or intrinsic value for entities that use either of those methods.

ASC paragraph 718-10-50-2(c)

INFORMATION FOR EACH YEAR FOR WHICH AN INCOME STATEMENT IS PROVIDED

7.009 In addition to the information required for the most recent period in Paragraph 7.008, detailed information is also required for *all* annual reporting periods presented, to enable the user to understand in detail the share-based payment arrangements in place for the reporting entity. These disclosure requirements are summarized in Example 7.2.

| Share-Based Payment Arrangement Details | Public or Nonpublic Entities Reporting at Fair Value (or Calculated Value) | Entity Reporting at Intrinsic Value |
|--|---|--|
| Weighted-average grant-date fair value (or calculated or intrinsic value for entities that use an alternative) of share options or other equity instruments granted during the year (\$) | X | X |
| Total intrinsic value of share options exercised ¹ (\$) | X | X |
| Total intrinsic value of share-based liabilities paid (\$) | X | X |
| Total fair value of shares vested (\$) | X | X |
| Assumptions Used in Estimating Fair Value (or Calculated Value) | | |
| Expected term of share options and similar instruments ^{2,3,4} (years) | X | — |
| Expected volatility (percent) ^{4,5} | X | — |

| | | |
|---|---|---|
| Expected dividends (percent) ⁶ | X | — |
| Risk-free rate(s) (percent) ³ | X | — |
| Discount for post-vesting restrictions ⁷ | X | — |
| Adjustment for material nonpublic information ¹¹ | X | — |
| ASC paragraph 718-10-50-2(d) | X | — |
| Total Compensation Cost Showing⁸ ASC paragraph 718-10-50-2(h) | | |
| Amount recognized in income ⁹ | X | X |
| Tax benefit recognized in income | X | X |
| Amount capitalized in fixed assets, inventory, or other assets ¹⁰ | X | X |

¹ Or share units converted.

² Additionally, the disclosure should describe of method used to incorporate the contractual term, expected suboptimal exercise, and expected post-vesting departure behavior into the valuation. If an entity chooses to use the simplified method of estimating the expected term allowed by SAB 107 and ASU 2018-07 for certain awards, it should disclose that fact. ASC paragraph 718-10-S99-1

³ Include the range, when applicable.

⁴ Disclose changes in assumptions in the period. ASC paragraph 718-10-S99-1

⁵ Additionally, disclosure should include the method used to estimate the expected volatility and describe how expected volatility was determined. For example, at a minimum, an entity should disclose whether it used only implied volatility, historical volatility, or a combination of both. In addition, an entity should disclose how it determined any significant adjustments to historical volatility. An entity that uses a method that employs different volatilities during the contractual term is required to disclose the range of expected volatilities used and the weighted-average expected volatility. A nonpublic entity that uses the calculated value method should disclose the reasons why it is not practicable for it to estimate the expected volatility of its share price, the appropriate industry sector index that it has selected, the reasons for selecting that particular index, and how it has calculated historical volatility using that index. ASC paragraphs 718-10-50-2(f)(2), and S99-1

⁶ Include range, weighted average, when applicable.

⁷ Include also the method of estimation.

⁸ We would expect the disclosure to include a reconciliation of the total cost of share-based payment arrangements attributed to the reporting period to the amount recognized in income for that period, exclusive of the related income tax benefit. This reconciliation should disclose amounts charged directly to expense in the current period and amounts capitalized in the current period, together with a description of the asset(s) to which capitalized amounts relate.

⁹ Include the current period amortization of amounts previously capitalized.

¹⁰ Disclosure would include tax benefit recognized on amount previously capitalized that is included in current period income.

¹¹ Disclosure would include the entity's accounting policy related to how it identifies when an adjustment to the closing price is required, how the current price of shares underlying share options was determined, including the amount of the adjustment to the closing share price, and any significant assumptions used to determine such adjustment, if material. SAB Topic 14.D.3

7.010 In addition to the quantitative information in Paragraph 7.009, some qualitative or descriptive disclosures are required. The following requirements apply for each year for which an income statement is presented:

- A description of the method used to estimate the fair value (or calculated value) of awards (entities reporting compensation cost using intrinsic value are exempt from this disclosure requirement); ASC paragraph 718-10-50-2(f)(1)
- A description of significant modifications, including the terms of the modifications, the number of grantees affected, and the total (or the lack of) incremental compensation cost resulting from the modifications. ASC paragraph 718-10-50-2(h)

Q&A 7.2: Applying Annual Disclosures Requirements to Modified Awards

Background

On January 1, 20X6, ABC Corp. grants 1,000 share options to its employees that cliff vest after three years of service. On June 30, 20X7, due to a decline in ABC's stock price, it modifies the share options to reduce the exercise price.

Q. How should these share options be disclosed in the rollforward share option table that is required under ASC paragraph 718-10-50-2(c)?

A. ABC could present the cancellation and reissuance of share options due to the modification on either a gross or net basis. In addition, in accordance with ASC subparagraph 718-10-50-2(c), ABC should disclose the basis for inclusion (gross or net) of the modified share options in the rollforward disclosure.

Q&A 7.2a: Disclosures for Modified Awards Not Requiring Modification Accounting

Q. If there is a change to the terms or conditions of a share-based payment award that does not result in the application of modification accounting (e.g. fair value, vesting conditions, and the classification as either a liability or equity instrument are the same immediately before and after the modification), do the disclosure requirements in ASC Topic 718 still apply?

A. Yes. The disclosure requirements in ASC Topic 718 apply regardless of whether an entity is required to apply modification accounting under the amendments to ASC Topic 718. Under ASC paragraph 718-10-50-2, a description of significant modifications is disclosed, including the total (or lack of) incremental compensation cost resulting from the modifications.

INFORMATION AS OF THE DATE OF THE LATEST STATEMENT OF FINANCIAL POSITION

7.011 The information in Example 7.3 is required to be disclosed for fully vested share options (or share units) and those expected to vest as of the date of the latest statement of financial position. If an entity's accounting policy is to account for forfeitures when they occur, the information in Example 7.3 also is required to be disclosed for unvested share options for which the employee's requisite service period or nonemployee's vesting period has not been rendered but that are expected to vest based on the achievement of a performance condition. ASC paragraph 718-10-50-2(e)

Example 7.3: Fully Vested Share Options, and Share Options Expected to Vest – Information Required as of the Date of the Latest Statement of Financial Position

| | Share Options (or Share Units) Outstanding | Share Options (or Share Units) Currently Exercisable (or Convertible) | Share Options Vested and Expected to Vest ² |
|---|---|---|---|
| Number | X | X | X |
| Weighted-average exercise price (or conversion ratio) | X | X | X |
| Aggregate intrinsic value ¹ | X | X | X |
| Weighted-average remaining contractual term | X | X | X |

¹ As amended per FSP FAS 123(R)-6, the aggregate intrinsic value disclosure is not required for nonpublic entities.

² Includes unvested share options for which the employee's requisite service period or nonemployee's vesting period has not been rendered but that are expected to vest based on the achievement of a performance condition.

ASC paragraph 718-10-50-2(e)

7.012 The reporting entity also should disclose the total remaining unrecognized compensation cost related to nonvested awards and the weighted-average period over which the cost is expected to be recognized. We believe that the reporting entity should also disclose the amount of the liability outstanding at the reporting date for liability-classified awards, when material. ASC paragraph 718-10-50-2(i)

Q&A 7.3: Separate Entity-Wide Policy Elections for Employees and Nonemployees and Related Disclosures

Q. Are separate entity-wide policy elections between employee awards and nonemployee awards required to be disclosed separately under ASC Topic 718?

A. We believe ASU 2018-07 permits separate entity-wide policies for employee and nonemployee awards. For example, because of the different attribution for nonemployee awards, a company may consider whether a separate forfeiture accounting policy is more appropriate for nonemployee awards compared with employee awards.

We believe that a company would continue to differentiate between employee and nonemployee share-based payment awards within its accounting records, which would require separate tracking to account for them correctly. Therefore, a company may need to disclose additional information in the notes to the financial statements that would be useful to investors and creditors, which may include related disclosures around a company's entity-wide policy elections and policy elections for nonemployee awards that differ from employee awards.

7.012a In addition, a reporting entity is required to disclose for each year for which an income statement is presented:

- The amount of cash received during the period from exercise of share options and similar instruments granted under share-based payment arrangements;
- The tax benefit from share options exercised during the annual period; and
- The amount of cash used during the period to settle equity instruments granted under share-based payment arrangements. ASC paragraphs 718-10-50-2(k) and 50-2A

7.012b The SEC Staff acknowledged that characteristics of share options may differ within an entity. For example, spring-loaded awards (see Paragraph 2.031a) issued by an entity may not have the same characteristics as other share-based payment arrangements. If that is the case, the SEC staff believes an entity should separately disclose information for these awards to allow investors to understand the entity's use of share-based compensation. SAB Topic 14.D.3 Question 2.

CASH FLOW INFORMATION

7.013 ASC Topic 230, *Statement of Cash Flows*, specifies that cash flows related to excess tax benefits be classified as an operating activity in the statement of cash flows. It also specifies that cash paid to a taxing authority for shares withheld to satisfy the employer's statutory income tax withholding obligation, is classified as a financing activity in the statement of cash flows. See Section 16 in KPMG Handbook, *Statement of Cash Flows*, for further guidance.

7.013a – 7.013c, 7.014 Not used.

Examples 7.4 – 7.7 Not used.

EXAMPLE DISCLOSURES

7.015 Example 7.8 provides illustrative disclosures required for share-based payment arrangements.

Example 7.8: Footnote Disclosures

Share-Based Payment Arrangements

At December 31, 20X9, ABC Corp. has two share-based payment plans for grantees as described below. Amounts recognized in the financial statements with respect to these plans are as follows:

| | Years Ended December 31 | | |
|---|-------------------------|---------------------|---------------------|
| | 20X9 (\$Million) | 20X8 (\$Million) | 20X7 (\$Million) |
| Total cost of share-based payment plans during the year | 29.6 | 28.5 | 23.4 |
| Amounts capitalized in inventory and fixed assets during the year | (0.5) | (0.2) | (0.4) |
| Amounts recognized in income for amounts previously capitalized in inventory and fixed assets | 0.3 | 0.4 | 0.3 |
| Amounts charged against income, before income tax benefit | 29.4 | 28.7 | 23.3 |
| Amount of related income tax benefit recognized in income | (10.3) | (10.1) | (8.2) |

ABC's accounting policy is to estimate forfeitures in determining the amount of total compensation cost to record each period.

Employee Share Option Plan

ABC's 20X2 Employee Share Option Plan (the Plan), which is shareholder-approved, permits the grant of share options and nonvested shares to its employees for up to 8 million shares of common stock. Share option awards are generally granted with an exercise price equal to the market price of ABC's shares at the date of grant; those share option awards generally vest based on five years of continuous service and have 10-year contractual terms. Certain share option and share awards provide for accelerated vesting if there is a change in control (as defined in the Plan).

The fair value of each share option award is estimated on the date of grant using a lattice option-pricing model based on the assumptions noted in the following table. Expected volatilities are based on implied volatilities from traded options on ABC's shares, historical volatility of ABC's shares, and other factors, such as expected changes in volatility arising from planned changes in ABC's business operations.

ABC uses historical data to estimate share option exercise and employee departure behavior used in the lattice option-pricing model; groups of employees (executives and non-executives) that have similar historical behavior are considered separately for valuation purposes. The expected term of share options granted is derived from the output of the option pricing model and represents the period of time that share options granted are expected to be outstanding; the range given below results from certain groups of employees exhibiting different post-vesting behaviors. The risk-free rate for periods within the contractual term of the share option is based on the U.S. Treasury yield curve in effect at the time of grant.

A summary of share option activity under the Plan as of December 31, 20X9, and changes during the year then ended is presented below.

Summary Details for Plan Share Options

| | Number of Shares (000) | Weighted -Average Exercise Price (\$) | Weighted- Average Remaining Contractua l Term (Years) | Aggregate Intrinsic Value (\$000) |
|----------------------------------|---|--|--|--|
| Outstanding at January 1, 20X9 | 4,660 | 42 | — | — |
| Granted | 950 | 60 | — | — |
| Exercised | (800) | 36 | — | — |
| Forfeited or expired | (80) | 59 | — | — |
| Outstanding at December 31, 20X9 | 4,730 | 47 | 6.5 | 85,140 |
| Exercisable at December 31, 20X9 | 3,159 | 41 | 4.0 | 75,816 |

As of December 31, 20X9, there was \$45.8 million of total unrecognized compensation cost related to share options granted under the Plan. That cost is expected to be recognized over a weighted-average period of 4.5 years. The total fair value of options vested during the years ended December 31, 20X9, 20X8, and 20X7 was \$20.6 million, \$22 million, and \$21.9 million, respectively.

The weighted-average grant-date fair value of share options granted during the years 20X9, 20X8, and 20X7 was \$19.57, \$17.46, and \$15.90, respectively. The total intrinsic

value of share options exercised during the years ended December 31, 20X9, 20X8, and 20X7 was \$25.2 million, \$20.9 million, and \$18.1 million, respectively.

Nonvested Shares Issued under the Plan. A summary of the status of ABC's nonvested shares as of December 31, 20X9, and changes during the year ended December 31, 20X9, is presented below.

| Nonvested Shares | Number of Shares (000) | Weighted- Average Grant- Date Fair Value (\$) |
|--------------------------------|-----------------------------------|--|
| Nonvested at January 1, 20X9 | 980 | 40.00 |
| Granted | 150 | 63.50 |
| Vested | (100) | 35.75 |
| Forfeited | (40) | 55.25 |
| Nonvested at December 31, 20X9 | 990 | 43.35 |

As of December 31, 20X9, there was \$25.9 million of total unrecognized compensation cost related to nonvested share-based compensation arrangements granted under the Plan. That cost is expected to be recognized over a weighted-average period of 4.9 years. The total fair value of shares vested during the years ended December 31, 20X9, 20X8, and 20X7 was \$22.8 million, \$21 million, and \$20.7 million, respectively.

During 20X9, ABC extended the contractual term of 200,000 fully vested share options held by 10 employees, all of whom are directors of ABC. As a result of that modification, ABC recognized additional compensation expense of \$1.0 million for the year ended December 31, 20X9. This modification was made to ensure the total remuneration of the individuals affected is competitive when compared with the remuneration of individuals employed in similar roles by ABC's peers.

Performance Share Option Plan

Under its 20X2 Performance Share Option Plan (the Performance Plan), which is shareholder-approved, each January 1, ABC grants selected executives and other key employees share option awards whose vesting is contingent on meeting various departmental and company-wide performance goals, including decreasing time to market for new products, revenue growth in excess of an index of competitors' revenue growth, and sales targets for Segment X. Share options under the Performance Plan are generally granted at the market value of the underlying share on the date of grant, contingently vest over a period of 1 to 5 years (depending on the nature of the performance goal), and have contractual terms of 7 to 10 years. The number of shares subject to share options available for issuance under the Performance Plan cannot exceed five million.

The fair value of each share option grant under the Performance Plan was estimated on the date of grant using the same option pricing model used for share options granted under the Plan and assumes that performance goals will be achieved. If such goals are not

met, no compensation cost is recognized and recognized compensation cost is reversed. The inputs used in estimating the fair value of share options granted under the Performance Plan are the same as those noted in the table related to share options issued under the Plan for expected volatility, expected dividends, and risk-free rate. The expected term for share options granted under the Performance Plan in 20X9, 20X8, and 20X7 is 3.3 to 5.4, 2.4 to 6.5, and 2.5 to 5.3 years, respectively.

A summary of the activity under the Performance Plan as of December 31, 20X9, and changes during the year then ended is presented below.

Summary Details for Performance Plan Share Options

| | Number of Shares (000) | Weighted -Average Exercise Price (\$) | Weighted- Average Remaining Contractual Term (Years) | Aggregate Intrinsic Value (\$000) |
|----------------------------------|---------------------------------|--|---|--|
| Outstanding at January 1, 20X9 | 2,533 | 44 | — | — |
| Granted | 995 | 60 | — | — |
| Exercised | (100) | 36 | — | — |
| Forfeited or expired | (604) | 59 | — | — |
| Outstanding at December 31, 20X9 | 2,824 | 47 | 7.1 | 50,832 |
| Exercisable at December 31, 20X9 | 936 | 40 | 5.3 | 23,400 |

The weighted-average grant-date fair value of share options granted during the years 20X9, 20X8, and 20X7 was \$17.32, \$16.05, and \$14.25, respectively. The total intrinsic value of share options exercised during the years ended December 31, 20X9, 20X8, and 20X7 was \$5 million, \$8 million, and \$3 million, respectively. As of December 31, 20X9, there was \$16.9 million of total unrecognized compensation cost related to nonvested share-based payment arrangements granted under the Performance Plan. That cost is expected to be recognized over a weighted-average period of 4.0 years.

Cash received from share option exercise under both share-based payment plans for the years ended December 31, 20X9, 20X8, and 20X7 is \$32.4 million, \$28.9 million, and \$18.9 million, respectively. The actual tax benefit for the tax deductions from option exercise of both share-based payment plans totaled \$11.3 million, \$10.1 million, and \$6.6 million, respectively, for the years ended December 31, 20X9, 20X8, and 20X7.

ABC has a policy of repurchasing shares on the open market to satisfy share option exercises and expects to repurchase approximately one million shares during 20Y0, based on estimates of those exercises for that period.

7.016 – 7.018 Not used.

SUPPLEMENTAL DISCLOSURES

7.019 In addition to the minimum disclosures prescribed in Paragraphs 7.003 through 7.013, a reporting entity may need to disclose additional information in the notes to the financial statements that management believes would be useful to investors and creditors. However, the additional information should be reasonable and should not lessen the prominence and credibility of the information required to be disclosed. The note containing such disclosures should contain a sufficient description to allow users of the financial statements to understand the information contained in the supplemental disclosures. Possible examples of supplemental disclosures are the disclosure of a range of share option values to illustrate the effect of different assumptions on fair value, and a disclosure of the functional categories (e.g., research and development) where the share-based payment compensation is reported in the income statement. Some entities also disclose a table showing ranges of exercise prices for all outstanding share options. ASC paragraph 718-10-50-4

Q&A 7.4 Disclosures in its Interim Financial Statements

Q. Are there voluntary disclosures an entity should consider making in its interim financial statements?

A. Yes, there are two categories of disclosures companies may want to consider in interim periods.

- **Large grants on a particular date.** Many entities grant the majority of their share-based payment awards at a single time each year. We believe generally that if such annual grants have a significant effect on the financial statements, the entity should provide interim disclosures consistent with the annual disclosure requirements in Topic 718 in the interim period the grants are made, so that financial statement users have current information on the company's share-based payment arrangements.
- **Significant share-based payment compensation cost.** When an entity's share-based compensation cost is significant, to help users better understand its interim financial information, an entity may want to disclose additional information for that interim period. Such information would include the total amount of share-based payment compensation cost.

Example 7.9: Interim Disclosure of Significant Share-Based Payment Compensation

On January 1, 20X2, ABC Corp. grants 100,000 share options to grantees with an option value of \$10 per share. The share options vest when there is a change in control, which is defined in the agreement as an acquisition of more than 50% of ABC's shares and/or when an IPO occurs. In 20X2, ABC discloses in its financial statements that it has entered into this share-based payment arrangement with its employees; however, it recognizes \$0 in compensation cost because it is not probable that the performance condition (change in control/IPO) will occur. ABC also does not recognize compensation cost in years 20X3-20X8. During Q3 20X9, ABC completes an IPO and the 100,000 share options vest. Accordingly, compensation cost of \$1 million is recorded for these awards in that quarter, which is a significant amount for ABC. In ABC's Q3 20X9 interim financial statements, ABC discloses additional information on the share-based compensation arrangement and related expense.

7.020 – 7.028b Not used.

DISCLOSURES RELATED TO THE VALUATION OF PRIVATE COMPANY SHARES

7.029 The AICPA has issued a Practice Aid addressing the valuation of privately-held-company equity securities issued as compensation, *Valuation of Privately-Held-Company Equity Securities Issued as Compensation*. Although the Practice Aid is not authoritative, it provides measurement guidance when valuing equity shares of a privately held entity and is intended to represent best practice. The Practice Aid also provides guidance on disclosures related to the valuations for financial reporting purposes of shares of privately held companies. In particular, the Practice Aid includes recommended disclosures for financial statements included in a registration statement to be filed with the SEC for share-based payment awards granted during the 12-month period prior to the date of the most recent statement of financial position included in the registration statement. The recommended disclosures are:

- For each grant date, the number of shares or share options granted, the exercise price, the fair value of the shares and the intrinsic value, if any, of the share options.
- Whether the valuation of the equity instruments was contemporaneous or retrospective.
- If the valuation specialist was a related party, a statement of that fact.
- When a valuation of equity instruments granted during the 12-month period prior to the date of the most recent statement of financial position included in a registration statement was based on a retrospective valuation or a valuation

by a related party, the Practice Aid recommends the following disclosures in Management's Discussion and Analysis:

- A description of the significant factors, assumptions, and methodologies used in the valuation.
- A discussion of each significant factor contributing to the difference between the fair value at the grant date and (1) the estimated IPO price or (2) if a contemporaneous valuation by an unrelated party was obtained after the grants but before the IPO, the difference in that value.
- The valuation alternative selected and the reason management chose not to obtain a contemporaneous valuation by an unrelated party.

7.030 We understand that the SEC staff expects entities to comply with the disclosure requirements of the Practice Aid in reports filed with the SEC.

7.030a A nonpublic entity that elects to apply the practical expedient for valuing share price by using a 'reasonable application of a reasonable valuation method' shall disclose that election. ASC paragraph 718-10-50-2(f)(2)(vi)

7.031 - 7.032 Not used.

EARNINGS PER SHARE

7.033 Computation of the effect of share-based payment awards on earnings per share is addressed in ASC Topic 260, *Earnings Per Share*, which requires that equity share options, nonvested shares, and similar instruments be treated as potential common shares in computing diluted earnings per share. The same concepts apply to the earnings per share computations regardless of the method of accounting for share-based payment arrangements. See Section 6.9.50 in KPMG Handbook, Earnings Per Share for further guidance.

7.034 - 7.071 Not used.

Q&A 7.5 – 7.7 Not used.

Examples 7.10 – 7.20f Not used.

Section 8 – Transition and Effective Dates

Detailed Contents

ASU 2024-01, Scope Application of Profits Interest and Similar Awards

ASU 2024-01, SCOPE APPLICATION OF PROFITS INTEREST AND SIMILAR AWARDS

8.000 ASU 2024-01 provides an illustrative example including four fact patterns to demonstrate how an entity would apply the scope guidance in ASC paragraph 718-10-15-3 to determine whether profits interest awards should be accounted for in accordance with ASC Topic 718. See Paragraph 1.053 for further discussion of profits interests and similar awards.

8.001 The following outlines the effective dates for ASU 2024-01 and the transition provisions. ASC paragraph 718-10-65-17

Effective dates and transition

| | Public business entities | All other entities |
|---|---|--------------------|
| Annual and interim periods – Fiscal years beginning after | December 15, 2024 | December 15, 2025 |
| Early adoption allowed? | Yes, for both interim and annual financial statements that have not yet been issued or made available to be issued. If an entity early adopts the ASU in an interim period, it is adopted as of the beginning of the annual period that includes that interim period. | |
| Transition | An entity may apply the ASU either: <ul style="list-style-type: none"> — Prospectively to awards granted or modified on or after the adoption date. — Retrospectively to all prior periods presented in the financial statements. | |

8.002 An entity that adopts the ASU prospectively should disclose the nature of and reason for the change in accounting principle. An entity that adopts retrospectively should provide the disclosures required by ASC paragraphs 250-10-50-1 through 50-3 (see section 3.3.40 of KPMG Handbook, Accounting changes and error corrections). ASC paragraph 718-10-65-17(d)

Section 9 – Business Combinations

See KPMG Handbook, *Business Combinations*, Section 11, Determining What Is Part of the Business Combination Transaction for replacement awards issued in a business combination. See KPMG Handbook, *Business Combinations*, Section 29, for awards issued in connection with a JV formation transaction after the effective date of ASU 2023-05, *Business Combinations – Joint Venture Formations (Subtopic 805-60)*, *Recognition and Initial Measurement*.

Section 10 – Equity-Based Transactions with Nonemployees

This publication has been fully updated for ASU 2018-07, *Improvements to Nonemployee Share-Based Payment Accounting*, and assumes that all entities have adopted ASU 2018-07.

Section 11 – Employee Stock Purchase Plans

Detailed Contents

Scope

Types of Look-Back Options

Q&A 11.1: ESPP with Fixed or Maximum Number of Shares

Measurement of Awards

Valuing Employee Share Purchase Plans with Look-Back Share Options

Example 11.1: Valuing a Type A Look-Back ESPP

Example 11.2: Valuing a Type B Look-Back ESPP

Other Measurement Issues

Accounting for Dividends in Employee Share Purchase Plans

Example 11.3: Valuing a Look-Back Option on a Dividend Paying Share

Foregone Interest on Withholdings

Example 11.4: Effects of Foregone Interest on Fair Value

Awards with Multiple Purchase Periods

Example 11.5: Valuing a Type C Plan

Grant Date for ESPPs Established with an IPO

Requisite Service Period for ESPPs

Forfeitures

Changes in Withholdings and Rollovers

Reset or Rollover of Plan Withholdings

Example 11.6: Multiple Purchase Periods and Rollover of Plan Withholdings (Type E Look-Back ESPP)

Example 11.7: Type E Plan – Straight-Line Versus Graded Vesting Attribution

Increase in Withholdings

Example 11.8: Accounting for an Increase in Withholdings

Decreases in Withholdings

Example 11.9: Accounting for a Decrease in Withholdings

Type I Plans

Example 11.9a: Determining Grant Date for a Retroactive Election to Increase Withholdings Part I

Example 11.9b: Determining Grant Date for a Retroactive Election to Increase Withholdings Part II

Suspension of an ESPP

Effect of Other GAAP on Initial Classification of an Award
Obligations Settled by Issuing a Variable Number of Shares
Disqualifying Dispositions

SCOPE

11.000 As described in Paragraphs 1.027 through 1.034, some entities offer employees the opportunity to purchase company shares typically at a discount from market price through an employee share purchase plan (ESPP). If certain conditions are met, the plan may qualify under Section 423 of the Internal Revenue Code for favorable tax treatment for the employees. Such plans are within the scope of ASC Topic 718, *Compensation--Stock Compensation*, and unless all the criteria specified in Paragraph 1.028 are met, an ESPP is considered compensatory. Many plans are compensatory because the discount offered to employees exceeds the permissible limit established in ASC Topic 718. Entities often provide employees the opportunity to acquire shares at a 15% discount from the current market price of the entity's stock. Additionally, many entities' ESPPs have *look-back* options. An example of a look-back option is a feature in the ESPP that allows employees to purchase the entity's stock at a 15% discount based on the lesser of the stock's market price at the grant date or at the exercise date. ASC paragraph 718-50-25-1

TYPES OF LOOK-BACK OPTIONS

11.001 ASC Section 718-50-55 identifies nine different types of look-back options and provides guidance on the measurement and recognition of compensation cost for those different features. The types of look-back options addressed in ASC paragraph 718-50-55-2 are:

- **Type A** – *Maximum number of shares*. Permits an employee to have withheld a fixed amount or fixed percentage from the employee's salary over a one-year enrollment period to purchase stock. At the end of the one-year period, the employee may purchase stock at a discount (e.g., 15%) off the lower of the grant-date stock price or the exercise-date stock price. However, the employee is limited to a fixed amount of shares based on the stock price and withholding amount at the grant date. Any excess cash is refunded to the employee.
- **Type B** – *Variable number of shares*. Same as Type A except that the employee may purchase as many shares as the full amount of the withholdings will permit, regardless of whether the exercise-date stock price is lower than the grant-date stock price.
- **Type C** – *Multiple purchase periods*. Permits an employee to have withheld a fixed amount or fixed percentage from the employee's salary over a two-year enrollment period to purchase stock. At the end of each six-month period, the employee may purchase stock at a discount (e.g., 15%) off the lower of the grant-date stock price or the exercise-date stock price based on the amount withheld during that period.
- **Type D** – *Multiple purchase periods with a reset mechanism*. Same as Type C except that the plan contains a reset feature. If the market price of the stock at the end of any six-month period is lower than at the original grant date, the plan resets so that during the next purchase period an employee may purchase stock at a discount (e.g., 15%) off the lower of the stock price at (1) the

beginning of the purchase period (rather than the original grant-date price) or (2) the exercise date.

- **Type E** – *Multiple purchase periods with a rollover mechanism.* Same as Type C except that the plan contains a rollover feature. If the market price of the stock at the end of any six-month purchase period is lower than the stock price at the original grant date, the plan is immediately canceled after that purchase date and a new two-year plan is established using the then-current stock price as the base purchase price.
- **Type F** – *Multiple purchase periods with semifixed withholdings.* Same as Type C except that the amount or percentage that an employee may elect to have withheld is not fixed and may be either increased or decreased at the employee's election immediately after each six-month purchase date for purposes of determining all future withholdings.
- **Type G** – *Single purchase period with variable withholdings.* Permits an employee to have withheld an amount or percentage over a one-year period. However, the amount or percentage is not fixed and may be either increased or decreased at the employee's election at any time during the term of the plan for purposes of all future withholdings. At the end of the one-year period, the employee may purchase stock at a discount (e.g., 15%) off the lower of the grant-date stock price or the exercise-date stock price.
- **Type H** – *Multiple purchase periods with variable withholdings.* Combines characteristics of Type C and Type G plans in that there are multiple purchase periods over the term of the plan and an employee is permitted to increase or decrease the withholding amounts or percentages at any time during the plan for purposes of all future withholdings under the plan.
- **Type I** – *Single purchase period with variable withholdings and cash infusions.* Same as Type G except that an employee is permitted to remit *catch-up* amounts to the entity when and if the employee increases withholding amounts or percentages. The cash infusion feature permits an employee to increase withholdings during the term of the plan such that the employee benefits as though he or she had participated at the higher amounts during the entire term of the plan.

Q&A 11.1: ESPP with Fixed or Maximum Number of Shares

Q. ABC Corp. has an ESPP that permits employees to buy a maximum of 10,000 shares per year. Does this qualify as a Type A plan?

A. It depends. We believe that although ASC Paragraph 718-50-55-2 describes a Type A plan as one with a maximum number of shares based on the stock price at grant date, whether an ESPP is considered a Type A or Type B plan depends on the facts and circumstances and how a fixed number of shares or a limitation on the number of shares affects the total value that can be purchased by the employee. For example, if the fixed or

maximum number of shares is equal to or less than the shares that could be purchased based on the stock price at grant date, the plan may be akin to a Type A plan. In contrast, if the maximum is greater than the number of shares that could be purchased based on the stock price at grant date, the plan may be more akin to a Type B plan.

MEASUREMENT OF AWARDS

Valuing Employee Share Purchase Plans with Look-Back Share Options

11.002 ASC paragraphs 718-50-55-10 through 55-21 provide guidance on the valuation of a Type A look-back option. ASC paragraphs 718-50-55-22 through 55-33 provide guidance on valuing other look-back arrangements. Paragraphs 2.162 through 2.174 address in detail the valuation of Types A and B look-back plans.

11.003 The approach described in ASC paragraphs 718-50-55-10 through 55-21 and 55-22 through 55-33 for a Type A plan estimates the fair value of a look-back option by valuing its separate option components. As shown in Example 11.1, the first component represents the minimum amount of benefits to the holder regardless of the price of the stock at the exercise date. The second component represents the additional benefit to the holder if the share price is above the exercise price at the exercise date.

Example 11.1: Valuing a Type A Look-Back ESPP

ABC Corp. has an ESPP that permits employees to buy shares at 85% of the lower of the grant-date share price or the share price at the end of one year. Thus, the employees have the ability to buy the maximum number of shares based on the grant-date enrollment amounts at a 15% minimum discount from the market price. Payment for the ESPP is made through payroll withholding over the enrollment period. ABC's stock price is \$50 per share at the grant date.

Because the exercise price is subject to the 85% adjustment of the lower of the grant-date share price or the end-of-year share price, the share option is always in-the-money by at least 15%. This means that the minimum payoff is 15% of the share price and this element of the share option is equivalent to 15% of a nonvested share.

The second element of the arrangement is the additional benefit that the employee can receive from the call option on 85% of a share.

Therefore, the grant-date fair value of a Type A award is calculated as follows.

| | |
|---|----------------|
| 0.15 of a share of nonvested stock ($\$50 \times 0.15$) | \$ 7.50 |
| One year call option on 0.85 of a share of stock ($\$7.56^1 \times 0.85$) | 6.43 |
| | <u>\$13.93</u> |

¹ The fair value of call option was derived from a standard option pricing model based on the following assumptions: \$50 stock and exercise price; expected term of one year; expected volatility of 30%; risk-free interest rate of 6.8%; and a zero dividend yield.

11.004 In a Type B plan, there is a third component of valuation because the number of shares that the employee can purchase is not a fixed amount. Consequently, the fair value of a Type B plan would be valued using the two components for a Type A plan plus the value of a put option on 15% of a share of stock.

11.005 For a Type B plan, total compensation cost is measured at the grant date based on the number of shares that can be purchased using the estimated total withholdings and market price of the stock as of the grant date, and is not measured based on the potentially greater number of shares that may ultimately be purchased if the market price declines. The fair value of the award is not measured based on the potentially greater number of shares because it has already been considered in the valuation of the put option.

Example 11.2: Valuing a Type B Look-Back ESPP

Assume the same facts as in Example 11.1, except that the employees can buy as many shares as their withholdings will permit.

The grant date fair value of the award is \$14.57, calculated as follows.

| | |
|--|-----------------|
| 0.15 of a share of nonvested stock ($\$50 \times 0.15$) | \$ 7.50 |
| One year call option on 0.85 of a share of stock ($\$7.56 \times 0.85$) | 6.43 |
| One year put option on 0.15 of a share of stock ($\$4.27^1 \times 0.15$) | 0.64 |
| | <u>\$ 14.57</u> |

¹ Assumptions are the same used to value the call option in Example 11.1.

OTHER MEASUREMENT ISSUES

Accounting for Dividends in Employee Share Purchase Plans

11.006 For a look-back option on a dividend-paying share, both the value of the nonvested stock component and the value of the share option component are adjusted to reflect the effect of the dividends that the employee does not receive during the term of the share option. The present value of the dividends expected to be paid on the stock during the term of the share option would be deducted from the value of a share that receives dividends. ASC paragraph 718-50-55-18

Example 11.3: Valuing a Look-Back Option on a Dividend Paying Share

Assume the same facts as in Example 11.1, except that ABC pays a quarterly dividend of 0.625% of the current share price.

The grant-date fair value of the awards would be calculated as follows.

| | |
|---|------------------------|
| 0.15 of share of nonvested stock ($\$50 \times 0.15 \times 1/(1+(0.00625 \times 4))$) | \$ 7.32 |
| One-year call option on 0.85 of a share of stock, exercise price of \$50 ($\$6.75^1 \times 0.85$) | <u>5.73</u> |
| Total grant date fair value | <u><u>\$ 13.05</u></u> |

¹ The fair value of call option was derived from a standard option pricing model based on the following assumptions: \$50 stock and exercise price; expected term of one year; expected volatility of 30%; risk-free interest rate of 6.8%; and a dividend yield of 0.625% per quarter.

Foregone Interest on Withholdings

11.007 The effect of interest foregone by the employee should be considered in determining the fair value of an award when the exercise price is paid over time through payroll withholdings. Awards for which part or the entire exercise price is paid before the exercise date are less valuable than awards for which the exercise price is paid at the exercise date, and it is appropriate to recognize that difference in applying ASC Topic 718.

Example 11.4: Effects of Foregone Interest on Fair Value

Assume the same facts as in Example 11.1. The following table shows the effects on fair value if the amounts are paid by an employee through payroll withholding in three different scenarios.

Assume that the fair value of 100 options of ABC common stock at grant date is \$13.93 and the interest rate and discount rate is 2.5% and 6.8%, respectively.

| | Option 1 Payment at Exercise Date | Option 2 \$354.17 per Month | Option 3 Payment at Grant Date |
|---|--|--|---|
| Unadjusted fair value of ABC's ESPP | \$ 1,393 | 1,393 | 1,393 |
| Less: Present value of interest income foregone | <u>0</u> | <u>56</u> | <u>99</u> |
| Adjusted fair value of ABC's ESPP | <u>\$ 1,393</u> | <u>1,337</u> | <u>1,294</u> |

Awards with Multiple Purchase Periods

11.008 As described in Paragraph 11.001, an ESPP may provide multiple purchase periods (Type C through Type F and Type H plans) beginning on a single date, which is similar in nature to a graded vesting share option plan. Accordingly, the fair value of an ESPP with multiple purchase periods should be determined at the grant date in the same manner as a share option plan with graded vesting. Under the graded vesting approach, awards under a two-year plan with purchase periods at the end of each year would be valued as having two separate option tranches both starting on the initial grant date (using either the Type A or Type B valuation methodology as appropriate for the plan) but with different terms of 12 and 24 months, respectively. All other measurement assumptions would be consistent with the separate terms of each tranche.

Example 11.5: Valuing a Type C Plan

On January 1, 20X6, when its stock price is \$50, ABC Corp. offers its employees the opportunity to sign up for payroll deduction to purchase its stock under a two-year Type C plan at the lower of 85% of the stock's current price or 85% of the stock price at the end of each year (12 and 24 months). Thus, the exercise price of the look-back options is the lesser of (a) \$42.50 ($\$50 \times 85\%$) or (b) 85% of the stock price at the end of the year when the option is exercised. The total number of shares the employee can purchase is limited to the number available to be purchased based on the grant date price (\$50) and the employee's withholding amount.

The fair value of each tranche of the award would be calculated at the grant date as follows.

Tranche No. 1

| | |
|---|------------------------|
| 0.15 of share of nonvested stock ($\$50 \times 0.15$) | \$ 7.50 |
| One-year call option on 0.85 of a share of stock, exercise price of \$50 ($\$7.56^1 \times 0.85$) | 6.43 |
| Total grant-date fair value of the first tranche | \$ <u><u>13.93</u></u> |

Tranche No. 2

| | |
|--|------------------------|
| 0.15 of share of nonvested stock ($\$50 \times 0.15$) | \$ 7.50 |
| One-year call option on 0.85 of a share of stock, exercise price of \$50 ($\$11.44^2 \times 0.85$) | 9.72 |
| Total grant-date fair value of the second tranche | \$ <u><u>17.22</u></u> |

¹ The fair value of call option was derived from a standard option pricing model based on the following assumptions: \$50 stock and exercise price; expected term of one year; expected volatility of 30%; risk-free interest rate of 6.8%; and a zero dividend yield.

² To simplify the illustration, the fair value of each of the tranches is based on the same assumptions about volatility, risk-free interest rate, and expected dividend yield. However, the fair value of the second tranche is estimated based on a two-year expected term. In addition, the adjustment for foregone interest described in Paragraph 11.007 and Example 11.4 is not shown.

GRANT DATE FOR ESPPS ESTABLISHED WITH AN IPO

11.008a In some cases, a company may undertake an IPO and offer a new ESPP, whereby the IPO date is the start of the ESPP enrollment period and the IPO price is the look-back price. In addition, as part of the ESPP, the enrollment period allows employees to enroll in the plan upon the IPO and modify their elections for a period of time after the IPO, resulting in a period of time in which the employees can decide to change or remove their ESPP elections post-IPO. As a result, the grant date is not established until the employees have committed to their withholding elections, because this is when there is a mutual understanding of the key terms and conditions of the ESPP award. The grant date is therefore the date on which the enrollment period ends, and also is the measurement date for the ESPP awards, even if the fair value of the awards on that date is higher than the IPO price.

REQUISITE SERVICE PERIOD FOR ESPPS

11.009 Consistent with the basic provisions of ASC Topic 718, the requisite service period for recognition of compensation cost for an ESPP is the period over which the employee participates in the plan. Generally, the requisite service period for an ESPP will be the purchase period. ASC paragraph 718-50-25-3

11.010 Under ASC Topic 718, the method of attribution recognition is not dependent on the entity's choice of valuation technique. Therefore, the accounting policy decision to recognize compensation cost for awards subject to graded vesting (see Paragraph 4.079) as either (1) over the requisite service period for each separately vesting portion (or tranche) of the award as if the award is, in substance, multiple awards, or (2) over the requisite service period for the entire award (for attribution purposes the award is treated as though it were cliff vesting) applies to ESPPs with multiple purchase periods and should be applied consistently to all similar awards (e.g., all similar awards subject to graded vesting). Accordingly, the policy election for ESPPs should be consistent with the policy election for all other similar awards. Generally, the policy election of ESPPs with multiple purchase periods should be consistent with the policy election for other similar graded vested awards. However, if an award is substantially different from other awards, then it could be permissible for a company to adopt a different policy election for the award than it uses for the dissimilar awards.

FORFEITURES

11.010a Similar to the forfeiture policy election allowed for other types of share-based payment awards (see Paragraph 4.087a), an entity with an ESPP should account for forfeitures based on its policy election to either estimate forfeitures or account for forfeitures when they occur. If an entity elects to estimate forfeitures, the forfeiture rate should be updated throughout the requisite service period and then again for actual forfeitures at the end of the requisite service period. An entity would consider factors such as expected withholdings that would be unused due to the termination of employment

prior to the purchase date, or whether the purchase periods are long (which may increase the forfeiture rate), to assist in estimating the forfeiture rate.

CHANGES IN WITHHOLDINGS AND ROLLOVERS

11.011 Plans with resets, rollovers, or changes in withholdings (Type D through Type I) are accounted for in a manner similar to a Type C plan. However, when or if the reset, rollover, or withholding changes occur, the changes are treated as a modification of the award.

Reset or Rollover of Plan Withholdings

11.012 The fair value of awards under an ESPP with multiple purchase periods that incorporates reset or rollover mechanisms (Type D and Type E plans), initially can be determined at the grant date using the graded vesting measurements approach as described in Paragraph 11.008. On the date that the reset or rollover mechanism becomes effective, the terms of the award are deemed to have been modified which, in substance, is similar to an exchange of the original award for a new award with different terms. Modification accounting should be applied at the date that the reset or rollover mechanism becomes effective to determine the amount of any incremental compensation associated with the modified award.

Example 11.6: Multiple Purchase Periods and Rollover of Plan Withholdings (Type E Look-Back ESPP)

On January 1, 20X6, when its stock price is \$50, ABC Corp. offers its employees the opportunity to sign up for payroll deduction to purchase its stock at the lower of 85% of the stock's current price or 85% of the stock price at the end of each six-month period for two years (6, 12, 18, and 24 months). Thus, the exercise price of the look-back options is the lesser of (a) \$42.50 ($\$50 \times 85\%$) or (b) 85% of the stock price at the end of the period when the option is exercised. If the stock price at any of the exercise dates is less than the original grant-date stock price, a new two-year plan is established at the new lower price. Employee X elects to withhold \$4,250 to purchase stock during the 24-month purchase period.

The grant-date fair value of the award for each tranche is calculated as follows.

| | 6-month Tranche | 12-month Tranche | 18-month Tranche | 24-month Tranche |
|--|--------------------|---------------------|---------------------|---------------------|
| 15% of share of nonvested stock ($\$50 \times 0.15$) | \$ 7.50 | 7.50 | 7.50 | 7.50 |
| Call option (fair value of call option $\times 85\%$) | 3.10 ¹ | 5.64 ² | 8.24 ³ | 11.96 ⁴ |
| Put option (fair value of put option $\times 15\%$) | 0.31 ⁵ | 0.50 ⁵ | 0.71 ⁵ | 1.10 ⁵ |
| Total value per share | \$ 10.91 | 13.64 | 16.45 | 20.56 |

| | | | | | |
|-------------------------|----|--------------------------|--------------------------|--------------------------|--------------------------|
| Number of shares | | <u>25.00⁶</u> | <u>25.00⁶</u> | <u>25.00⁶</u> | <u>25.00⁶</u> |
| Total compensation cost | \$ | <u>272.75</u> | <u>341.00</u> | <u>411.25</u> | <u>\$514.00</u> |

¹ The fair value of call option was derived from a standard option pricing model based on the following assumptions: \$50 stock and exercise price; expected term of 6 months; expected volatility of 20%; risk-free interest rate of 6.5%; and a zero dividend yield

² The fair value of call option was derived from a standard option pricing model based on the following assumptions: \$50 stock and exercise price; expected term of 1 year; expected volatility of 25%; risk-free interest rate of 6.8%; and a zero dividend yield

³ The fair value of call option was derived from a standard option pricing model based on the following assumptions: \$50 stock and exercise price; expected term of 18 months; expected volatility of 30%; risk-free interest rate of 7.0%; and a zero dividend yield

⁴ The fair value of call option was derived from a standard option pricing model based on the following assumptions: \$50 stock and exercise price; expected term of 2 years; expected volatility of 40%; risk-free interest rate of 7.2%; and a zero dividend yield

⁵ The fair value of each of the put options was derived from the same assumptions used to value the respective call options.

⁶ The number of shares for the original awards was calculated based on the total withholdings divided by 85% of the current stock price = $(\$4,250 / \$42.50) / 4 = 25$ shares

On December 31, 20X6, the share price decreases to \$40.

Because the share price decreased from \$50 to \$40, the plan is extended by a year because the rollover mechanism is triggered and the exercise price of the remaining two tranches is reduced. Accordingly, a modification has occurred and ABC must calculate the incremental fair value attributable to the modification and recognize the incremental value, along with previously unrecognized compensation cost over the remaining service period.

There is no further accounting required for the original 6-month and 12-month tranches because they were vested as of December 31, 20X6. However, for the 18-month and 24-month tranches, a comparison of the fair value of the original award (at the modification date) to the fair value of modified award is required.

| | | 18-month Tranche (Modified Award) | 18-month Tranche (Original Award) | 24-month Tranche (Modified Award) | 24-month Tranche (Original Award) |
|--|----|--|--|--|--|
| 15% of share of nonvested stock ($\$40 \times 0.15$) | \$ | 6.00 | 6.00 | 6.00 | 6.00 |
| Call option (fair value of call option \times 85%) | | 3.38 ¹ | 0.79 ² | 6.36 ³ | 3.38 ⁴ |
| Put option (fair value of put option \times 15%) | | <u>0.41⁵</u> | <u>1.41⁵</u> | <u>0.74⁵</u> | <u>1.63⁵</u> |
| Total value per share | \$ | <u>9.79</u> | <u>8.20</u> | <u>13.10</u> | <u>11.01</u> |
| Number of shares | | <u>31.25⁶</u> | <u>31.25⁶</u> | <u>31.25⁶</u> | <u>31.25⁶</u> |
| Total compensation cost | \$ | <u>305.94</u> | <u>256.25</u> | <u>409.38</u> | <u>344.06</u> |

| | | |
|---|-----------------|--------------|
| Incremental compensation cost due to modification | \$ <u>49.69</u> | <u>65.32</u> |
|---|-----------------|--------------|

¹ The fair value of call option was derived from a standard option pricing model based on the following assumptions: \$40 stock and exercise price; expected term of 6 months; expected volatility of 30%; risk-free interest rate of 6.2%; and a zero dividend yield

² The fair value of call option was derived from a standard option pricing model based on the following assumptions: \$40 stock price; \$50 exercise price; expected term of 6 months; expected volatility of 30%; risk-free interest rate of 6.2%; and a zero dividend yield

³ The fair value of call option was derived from a standard option pricing model based on the following assumptions: \$40 stock and exercise price; expected term of 1 year; expected volatility of 40%; risk-free interest rate of 6.5%; and a zero dividend yield

⁴ The fair value of call option was derived from a standard option pricing model based on the following assumptions: \$40 stock price; \$50 exercise price; expected term of 1 year; expected volatility of 40%; risk-free interest rate of 6.5%; and a zero dividend yield

⁵ The fair value of the put options was derived from the same assumptions used to value the respective call options

⁶ The number of shares for the modified awards was calculated based on the total withholdings divided by 85% of the current stock price = $(\$4,250 / \$34) / 4 = 31.25$ shares

Practice is mixed with respect to the total number of shares to be used. We believe using either the original withholding amount divided by 85% of the original stock price (which, in this example, would be 25 shares for each tranche) or 85% of the current stock price is acceptable.

Accordingly, ABC would recognize the incremental amount attributable to the modification (\$49.69 for the 18-month tranche and \$65.32 for the 24-month tranche) along with previously unrecognized compensation cost over the remaining 6-month and 12-month service periods, respectively, in accordance with their policy election of straight-line or graded vesting attribution method (see Example 11.7).

In addition, due to the decrease in share price, the plan is extended by a year because the rollover mechanism was triggered. This results in additional compensation cost to be recognized for the new 18-month and 24-month tranches.

| | Incremental 18-month Tranche (New Award) | Incremental 24-month Tranche (New Award) |
|--|---|---|
| 15% of share of nonvested stock ($\$40 \times 0.15$) | \$ 6.00 | 6.00 |
| Call option (fair value of call option \times 85%) | 8.64 ¹ | 10.84 ² |
| Put option (fair value of put option \times 15%) | 0.94 ³ | 1.13 ³ |
| Total value per share | <u>\$ 15.58</u> | <u>17.97</u> |
| Number of shares | <u>31.25⁴</u> | <u>31.25⁴</u> |
| Total compensation cost | <u>\$ 486.88</u> | <u>561.56</u> |

¹ The fair value of call option was derived from a standard option pricing model based on the following assumptions: \$40 stock and exercise price; expected term of 18 months; expected volatility of 44%; risk-free interest rate of 6.8%; and a zero dividend yield

² The fair value of call option was derived from a standard option pricing model based on the following assumptions: \$40 stock and exercise price; expected term of 24 months; expected volatility of 48%; risk-free interest rate of 7.0%; and a zero dividend yield

³ The fair value of the put options was derived from the same assumptions used to value the respective call options

⁴ The number of shares for the incremental awards was calculated based on the total withholdings divided by 85% of the current stock price = $(\$4,250 / \$34) / 4 = 31.25$ shares. (It would not be acceptable to use 25 shares for these two tranches as the purpose of this calculation is to determine the effect of the modification for the two tranches described in footnote 6 in the immediately preceding table.)

Example 11.7: Type E Plan – Straight-Line Versus Graded Vesting Attribution

In recognizing compensation cost for awards with graded vesting (such as a Type E plan), the company should apply the same policy election as it does to other share-based payment awards with graded vesting and a service condition. Using the information from Example 11.6 before considering the modification, the amount of compensation cost recognized under the straight-line versus graded vesting attribution method is shown below.

| Tranche | Graded Vesting Attribution Value | Period | 12/31/20X6 | | 12/31/20X7 | |
|-----------|----------------------------------|--------|-----------------|--------|---------------|------|
| | | | Cost | Period | Cost | Cost |
| 6-months | \$ 272.75 | 1/1 | 272.75 | | | |
| 12-months | 341.00 | 2/2 | 341.00 | | | |
| 18-months | 411.25 | 2/3 | 274.17 | 1/3 | 137.08 | |
| 24-months | 514.00 | 2/4 | 257.00 | 2/4 | 257.00 | |
| Total | \$ <u>1,539.00</u> | | <u>1,144.92</u> | | <u>394.08</u> | |

Accordingly, under the straight-line attribution approach, the compensation cost would be \$769.50 ($\$1,539 / 2$ years) for 20X6 and 20X7. Under the graded vesting attribution approach, the compensation cost would be \$1,144.92 in 20X6 and \$394.08 in 20X7.

It should be noted that the policy election for ESPP plans should be consistent with the policy election for similar awards (e.g., other graded vesting awards with only a service condition).

Increase in Withholdings

11.013 An election by an employee to increase withholding amounts or percentages for future services (Type F through Type H plans) is a modification of the terms of the award to that employee, which, in substance, is similar to an exchange of the original award for a new award with different terms. The fair value of an award under an ESPP with variable withholdings should be determined at the grant date (using the Type A, Type B, or Type C measurement approach, as applicable) based on the estimated amounts or percentages that a participating employee initially elects to withhold under the terms of the plan. Subsequent to the grant date, any increases in withholding amounts or percentages for future services should be accounted for as a plan modification in accordance with the guidance described in Section 5, *Modification of Awards*.

11.014 However, increases in withholdings due to increases in salary, commissions, or bonus payments are not plan modifications if they do not represent changes to the terms of the award offered by the employer and initially agreed to by the employee at the grant (or measurement) date. Under those circumstances, the only incremental compensation cost is that which results from the additional shares an employee may purchase with the additional amounts withheld (using the fair value calculated at the grant date). ASC paragraph 718-50-35-1

Example 11.8: Accounting for an Increase in Withholdings

On January 1, 20X6, when its stock price is \$30, DEF Corp. offers its employees the opportunity to sign up for payroll deduction to purchase its stock at the lower of 85% of the stock's current price or 85% of the exercise date stock price. Thus, the exercise price of the look-back options is the lesser of (a) \$25.50 ($\$30 \times 85\%$) or (b) 85% of the stock price at the end of the year when the option is exercised. Employee X initially elects to withhold \$510. Accordingly, \$510 can buy 20 shares ($\$510 / \25.50) as of the grant date. At the end of Year 1, the stock increases to \$40 and Employee X increases withholding to \$765, which allows Employee X to purchase 30 shares ($\$765 / \25.50).

The fair value per share at the modification date is \$19.85 calculated as follows.

| | |
|--|------------------------|
| 0.15 of share of nonvested stock ($\$40 \times 0.15$) | \$ 6.00 |
| One-year call option on 0.85 of a share of stock, exercise price of \$30 ($\$16.30^1 \times 0.85$) | <u>13.85</u> |
| Fair value per share at the modification date | <u><u>\$ 19.85</u></u> |

Total incremental cost is calculated as follows.

| | |
|---|----------------------|
| Fair value of the original award at the modification (20 shares × \$19.85) | \$ 397 |
| Fair value of the award after the modification (30 shares × \$19.85) | <u>596</u> |
| Total incremental cost | <u><u>\$ 199</u></u> |

¹ The fair value of call option was derived from a standard option pricing model based on the following assumptions: \$40 stock price; exercise price of \$30; expected term of 1 year; expected volatility of 30%; risk-free interest rate of 6.8%; and a zero dividend yield.

11.014a Type I plans permit an employee to make a retroactive election to increase withholdings, which differs from Type F through Type H plans, which permit an employee to increase withholding amounts (or percentages) only prospectively. Under a Type I plan, an employee may participate minimally, or elect not to participate in the plan until just before the exercise date. Because of the retroactive election permitted under Type I plans, it can be difficult to determine their grant dates, as well as whether there is a mutual understanding of the terms of the award (see Paragraphs 11.016-11.017 and Example 11.9a).

Decreases in Withholdings

11.015 Decreases in the withholding amounts or percentages should be disregarded for purposes of recognizing compensation cost. That is, a decrease in the withholding amounts or percentages is tantamount to a notification by the employee of intent not to exercise. Consistent with the accounting for a share option that is fully vested, compensation cost would not be reversed if the award subsequently expires unexercised. However, if the employee departs before the end of the requisite service period, no compensation cost should be recognized because the employee forfeits the award by failing to satisfy a service requirement for vesting. Conversely, if an employee withdraws from the plan but remains an employee of the company, this would be accounted for as a cancellation of the award and any unrecognized compensation cost would be recorded on the date of withdrawal. ASC paragraph 718-50-35-2

Example 11.9: Accounting for a Decrease in Withholdings

Assume the same information as in Example 11.6. Based on Employee X's initial withholding amount of \$4,250, the total compensation cost was determined to be \$1,539. ABC Corp. uses straight-line attribution for all share-based payment awards with graded vesting that vest on satisfaction of a service condition. As such, ABC recognizes compensation cost of \$769.50 per year.

At the end of the initial six-month period, Employee X elects to reduce the withholding amount to \$2,125.

Because a decrease in withholding is treated as a decision by the employee not to exercise rather than a modification, cancellation, or forfeiture, ABC would continue to recognize compensation cost based on the originally computed \$1,539 of total compensation cost. This accounting consequence is different from when an employee withdraws from the plan and remains with the company. In such circumstances, the award is considered cancelled (see Paragraph 11.015).

Type I Plans

11.016 As described in Paragraph 11.001, a Type I plan has unique features not found in the other types of ESPPs. Unlike Type F through Type H plans where the employee can increase the withholding amount or percentage only for future periods, a Type I plan allows employees to increase withholding amounts or percentages retroactively. Consequently, under a Type I plan, an employee may initially elect not to participate in the plan and then may join shortly before the exercise date by making a retroactive cash infusion.

11.017 Because of the ability to delay enrollment in the plan or to retroactively adjust the withholding amounts or percentages, ASC paragraph 718-50-55-32 notes that it is difficult to determine when there has been a mutual understanding of the terms of the award between the employer and the employee. Consequently, for Type I plans, the grant date does not occur until the mutual understanding is established, which is often at or near the exercise date when the employee is committed to acquire a determinable number of shares or can no longer change the withholding amounts.

Example 11.9a: Determining Grant Date for a Retroactive Election to Increase Withholdings Part I

An ESPP of ABC Co. permits an employee to remit amounts under the Type I plan (up to a maximum aggregate withholding of 10% of the employee's annual salary) to ABC at any time during the term of the plan).

On January 1, 20X8, an employee elects to participate in the plan by having \$500 withheld monthly from the employee's pay (which represents less than 10%, or approximately 2%, of the employee's annual salary). On December 7, 20X8, when the stock price is \$50, the employee elects to remit a check to ABC for \$20,000, which, together with the \$6,000 withheld during the year, represents 10% of the employee's salary.

As a result, December 7, 20X8 is the date at which ABC and the employee have a mutual understanding of the terms of the award in exchange for the services already rendered. Therefore, the fair value of the entire award to the employee is measured as of December 7, 20X8, which is the date at which the maximum aggregate withholding of 10% of the employee's annual salary is reached.

Example 11.9b: Determining Grant Date for a Retroactive Election to Increase Withholdings Part II

Assume the same facts as Example 1.1a. However, on December 7, 20X8, when the stock price is \$50, the employee elects to remit a check to ABC for \$10,000 (instead of \$20,000), which together with the \$6,000 withheld during the year, represents 6% of the employee's annual salary. In this scenario, the grant date is December 31, 20X8 (i.e., the end of the period in which the employee can remit amounts up to the 10% limit under the plan). As the employee did not reach the maximum aggregate withholding of 10% of its annual salary by December 31, 20X8 and the employee is permitted to remit retroactive cash infusion any time until December 31, 20X8, such an arrangement implies that ABC and the employee do not have a mutual understanding of the terms and conditions until either the 10% limit is reached or December 31, 20X8. Therefore, in this example measurement is delayed until an understanding is obtained (at the end of the period in which the employee can remit amounts up to the 10% limit under the plan).

Suspension of an ESPP

11.018 The suspension of an ESPP is accounted for in the same manner as a cancellation under ASC Topic 718 (see discussion beginning at Paragraph 5.032). An award that is cancelled without a replacement award or other form of consideration given to the employee should be accounted for as a repurchase for no consideration. However, any amounts refunded to the employee for shares that were not purchased are not consideration for the repurchase of the awards. Rather, those amounts constitute a reimbursement of the exercise price that was paid in advance by the employee (i.e., a refund of the employee deposit amount). As a result, compensation cost previously recognized on the ESPP is not reversed and any unrecognized compensation is recognized in the period the ESPP is suspended. The suspension of the ESPP does not constitute a forfeiture with a reversal of compensation cost because a forfeiture refers to an award that is terminated when employees depart from service prior to completing the requisite service or performance condition rather than a cancellation or suspension of the plan by the employer while the employees remain in service.

EFFECT OF OTHER GAAP ON INITIAL CLASSIFICATION OF AN AWARD

Obligations Settled by Issuing a Variable Number of Shares

11.019 As described in Paragraph 3.072, ASC paragraph 480-10-25-14 requires that compensation cost for an award that may be variable-share-settled to be classified as a liability on the balance sheet. Awards that are variable-share-settled arise more frequently when the ESPP provides a fixed discount from the share price on the purchase date and does not include a look-back feature. Example 3.14 describes the classification of the ESPP award.

DISQUALIFYING DISPOSITIONS

11.020 For ESPPs, a disposition of shares prior to the end of the holding period specified in Section 423 of the Internal Revenue Code can result in a tax deduction for the entity that otherwise would not have been available because ESPPs generally do not result in a tax benefit for the employer unless there is a disqualifying disposition by the employee. Accordingly, deferred taxes are not recognized on the compensation cost recognized for ESPPs at the time the compensation cost is recognized in the income statement because the availability of the tax benefits is outside the entity's control. Regardless of an entity's experience with disqualifying events, ASC Topic 718 does not permit an entity to anticipate disqualifying dispositions in recognizing deferred taxes as compensation cost is recognized in the income statement. Accordingly, the tax benefits from disqualifying dispositions are recognized in the period that a disqualifying event occurs. At the time of the disqualifying event, the tax benefit recognized in earnings is equal to the lesser of: (i) the actual benefit of the tax benefit realizable from the tax deduction or (ii) the cumulative compensation cost previously recognized in earnings for the disqualified award multiplied by the applicable tax rate. If there is any excess benefit realized at the time of the disqualifying event, this excess amount is recognized as an increase to income tax benefit.

KPMG Financial Reporting View

Delivering guidance and insights, KPMG Financial Reporting View is ready to inform your decision making. Stay up to date with us.



Defining Issues

Our collection of newsletters with insights and news about financial reporting and regulatory developments, including Quarterly Outlook and FRV Weekly.



Handbooks and Hot Topics

Our discussion and analysis of accounting topics – from short Hot Topics that deal with a topical issue, to our in-depth guides covering a broad area of accounting.



CPE opportunities

Register for live discussions of topical accounting and financial reporting issues. CPE-eligible replays also available.



Financial Reporting Podcasts

Tune in to hear KPMG professionals discuss major accounting and financial reporting developments.



Visit **Financial Reporting View** and sign up for news and insights

Access our US Handbooks

As part of [Financial Reporting View](#), our library of in-depth guidance can be accessed [here](#), including the following Handbooks.

- Accounting changes and error corrections
- Asset acquisitions
- Bankruptcies
- Business combinations
- Business combinations (SEC reporting)
- Climate risk in the financial statements
- Consolidation
- Credit impairment
- Debt and equity financing
- Derivatives and hedging
- Discontinued operations and held-for-sale disposal groups
- Earnings per share
- Employee benefits
- Equity method of accounting
- Fair value measurement
- Financial statement presentation
- Foreign currency
- GHG emissions reporting
- Going concern
- IFRS® compared to US GAAP
- Impairment of nonfinancial assets
- Income taxes
- Internal control over financial reporting
- Inventory
- Investments
- Leases
- Leases: Real estate lessors
- Long-duration contracts
- Reference rate reform
- Research and development
- Revenue recognition
- Revenue: Real estate
- Revenue: Software and SaaS
- Segment reporting
- Service concession arrangements
- Share-based payment
- Software and website costs
- Statement of cash flows
- Tax credits
- Transfers and servicing of financial assets

Acknowledgments

This Handbook has been produced by the Department of Professional Practice (DPP) of KPMG LLP in the United States.

We would like to acknowledge the efforts of the main contributors to this edition:

[Nick Burgmeier](#)

[Rivka Grund-Sender](#)

[Joe Osterbauer](#)

We would also like to acknowledge the current and former members of DPP who contributed significantly to this Handbook: Kimber Bascom, Brittany Bockman, Frederick Bort, Regina Croucher, Val Mosier, Mike Kraehnke, Lisa Munro, Mahesh Narayanasami, Ellen Russo, Karen Silverman and Meaghan Wrona.

Learn about us:



[kpmg.com](https://www.kpmg.com)

The FASB Accounting Standards Codification® material is copyrighted by the Financial Accounting Foundation, Norwalk, Connecticut.

© 2024 KPMG LLP, a Delaware limited liability partnership and a member firm of the KPMG global organization of independent member firms affiliated with KPMG International Limited, a private English company limited by guarantee. All rights reserved. USCS013296-1A

The KPMG name and logo are trademarks used under license by the independent member firms of the KPMG global organization.

The information contained herein is of a general nature and is not intended to address the circumstances of any particular individual or entity. Although we endeavor to provide accurate and timely information, there can be no guarantee that such information is accurate as of the date it is received or that it will continue to be accurate in the future. No one should act upon such information without appropriate professional advice after a thorough examination of the particular situation.

This publication contains copyright © material of the IFRS® Foundation. All rights reserved. Reproduced by KPMG LLP with the permission of the IFRS Foundation. Reproduction and use rights are strictly limited. For more information about the IFRS Foundation and rights to use its material please visit www.ifrs.org.

Disclaimer: To the extent permitted by applicable law the IASB, the ISSB and the IFRS Foundation expressly disclaims all liability howsoever arising from this publication or any translation thereof whether in contract, tort or otherwise (including, but not limited to, liability for any negligent act or omission) to any person in respect of any claims or losses of any nature including direct, indirect, incidental or consequential loss, punitive damages, penalties or costs.

Information contained in this publication does not constitute advice and should not be substituted for the services of an appropriately qualified professional.

'ISSB™' is a Trade Mark and 'IFRS®', 'IASB®', 'IFRIC®', 'IFRS for SMEs®', 'IAS®' and 'SIC®' are registered Trade Marks of the IFRS Foundation and are used by KPMG LLP under licence subject to the terms and conditions contained therein. Please contact the IFRS Foundation for details of countries where its Trade Marks are in use and/or have been registered.